

Lecture Notes in Civil Engineering

Johannes Fottner  
Konrad Nübel  
Dominik Matt *Editors*

# Construction Logistics, Equipment, and Robotics

Proceedings of the CLEaR  
Conference 2023

 Springer

## Series Editors

Marco di Prisco, *Politecnico di Milano, Milano, Italy*

Sheng-Hong Chen, *School of Water Resources and Hydropower Engineering, Wuhan University, Wuhan, China*

Ioannis Vayas, *Institute of Steel Structures, National Technical University of Athens, Athens, Greece*

Sanjay Kumar Shukla, *School of Engineering, Edith Cowan University, Joondalup, WA, Australia*

Anuj Sharma, *Iowa State University, Ames, IA, USA*

Nagesh Kumar, *Department of Civil Engineering, Indian Institute of Science Bangalore, Bengaluru, Karnataka, India*

Chien Ming Wang, *School of Civil Engineering, The University of Queensland, Brisbane, QLD, Australia*

Zhen-Dong Cui, *China University of Mining and Technology, Xuzhou, China*

**Lecture Notes in Civil Engineering** (LNCE) publishes the latest developments in Civil Engineering—quickly, informally and in top quality. Though original research reported in proceedings and post-proceedings represents the core of LNCE, edited volumes of exceptionally high quality and interest may also be considered for publication. Volumes published in LNCE embrace all aspects and subfields of, as well as new challenges in, Civil Engineering. Topics in the series include:

- Construction and Structural Mechanics
- Building Materials
- Concrete, Steel and Timber Structures
- Geotechnical Engineering
- Earthquake Engineering
- Coastal Engineering
- Ocean and Offshore Engineering; Ships and Floating Structures
- Hydraulics, Hydrology and Water Resources Engineering
- Environmental Engineering and Sustainability
- Structural Health and Monitoring
- Surveying and Geographical Information Systems
- Indoor Environments
- Transportation and Traffic
- Risk Analysis
- Safety and Security

To submit a proposal or request further information, please contact the appropriate Springer Editor:

- Pierpaolo Riva at [pierpaolo.riva@springer.com](mailto:pierpaolo.riva@springer.com) (Europe and Americas);
- Swati Meherishi at [swati.meherishi@springer.com](mailto:swati.meherishi@springer.com) (Asia—except China, Australia, and New Zealand);
- Wayne Hu at [wayne.hu@springer.com](mailto:wayne.hu@springer.com) (China).

**All books in the series now indexed by Scopus and EI Compendex database!**

Johannes Fottner · Konrad Nübel · Dominik Matt  
Editors

# Construction Logistics, Equipment, and Robotics

Proceedings of the CLEaR Conference 2023

*Editors*

Johannes Fottner  
TUM School of Engineering and Design,  
Chair of Materials Handling,  
Material Flow, Logistics  
Technical University of Munich  
Garching near Munich, Germany

Konrad Nübel  
TUM School of Engineering and Design,  
Chair for Construction Management  
Technical University of Munich  
Munich, Germany

Dominik Matt  
Chair for Production Systems  
and Technologies, Head of Research  
Area "Industrial Engineering  
& Automation (IEA)"  
Free University of Bozen-Bolzano,  
Faculty of Engineering  
Bozen-Bolzano, Italy

ISSN 2366-2557

ISSN 2366-2565 (electronic)

Lecture Notes in Civil Engineering

ISBN 978-3-031-44020-5

ISBN 978-3-031-44021-2 (eBook)

<https://doi.org/10.1007/978-3-031-44021-2>

© The Editor(s) (if applicable) and The Author(s), under exclusive license  
to Springer Nature Switzerland AG 2024

This work is subject to copyright. All rights are solely and exclusively licensed by the Publisher, whether the whole or part of the material is concerned, specifically the rights of translation, reprinting, reuse of illustrations, recitation, broadcasting, reproduction on microfilms or in any other physical way, and transmission or information storage and retrieval, electronic adaptation, computer software, or by similar or dissimilar methodology now known or hereafter developed.

The use of general descriptive names, registered names, trademarks, service marks, etc. in this publication does not imply, even in the absence of a specific statement, that such names are exempt from the relevant protective laws and regulations and therefore free for general use.

The publisher, the authors, and the editors are safe to assume that the advice and information in this book are believed to be true and accurate at the date of publication. Neither the publisher nor the authors or the editors give a warranty, expressed or implied, with respect to the material contained herein or for any errors or omissions that may have been made. The publisher remains neutral with regard to jurisdictional claims in published maps and institutional affiliations.

This Springer imprint is published by the registered company Springer Nature Switzerland AG  
The registered company address is: Gewerbestrasse 11, 6330 Cham, Switzerland

Paper in this product is recyclable.

# Preface

The CLEaR Conference 2023 focused on the exciting topics of construction logistics, equipment, and robotics.

Current social and ecological efforts challenge all three areas. For example, construction logistics must finally be recognized and promoted as a sub-sector in its own right: Trouble-free construction site operations are only possible with efficient construction logistics. This efficiency requires new logistics concepts and intelligent tools. Because of advancing digitalization and automation, construction machinery has unique opportunities to work more climate-friendly and resource-savvily. Especially about construction robotics, there is new thinking for the construction industry—where do the machine end and robotics begin? Is the construction worker a discontinued model? This year's CLEaR Conference 2023 participants dealt with these and many other questions.

It aimed to strengthen the construction research field and promote collaboration between universities and research institutions.

The close link between construction logistics, equipment, and robotics offers enormous potential for optimization and innovation in the construction industry. By exploring and studying these areas together, we can gain new insights and lead the construction industry into a successful and more sustainable future.

The CLEaR Conference 2023 served as an exchange platform for scientists, experts, and professionals from the construction industry. During the conference, they had the opportunity to present and discuss their latest research and developments in construction logistics, equipment, and robotics. This open dialog allowed the conference participants to expand their knowledge and gain new innovative perspectives.

Our book, containing the scientific publications of the CLEaR Conference 2023, provides a comprehensive collection of papers reflecting the broad spectrum of the meeting. The research results testify to the authors' dedication and commitment to pushing the boundaries of knowledge in civil engineering.

The review process for the conference consists of two stages. Two independent reviewers evaluated the submitted papers in the first review. Each reviewer assessed the proceedings based on various criteria, such as originality, relevance, and methodological strength. Following this, the authors received the reviewers' feedback and had the opportunity to incorporate it into their work and make improvements. After the revised versions were submitted, the second review took place. The revised papers were reviewed again by two independent reviewers, who evaluated them based on the same criteria. The authors had another chance to consider the reviewers' feedback and make further improvements. Finally, the reviewers examined the revised versions of the papers and decided to accept or reject them. The decision was based on the revised version's quality and adherence to the evaluation criteria. The two-stage review process enabled a thorough assessment of the submitted papers, promoted dialogue between authors and reviewers, and ensured a high quality of the works presented at the conference.

The first part of the book explores various aspects of efficient and effective logistics management in the construction industry. It delves into issues such as supply chain management, process optimization, lean and industrialized construction, and implementing building information modeling (BIM) and digital twins in logistics.

The second part of the book, construction equipment, focuses on the advancements and innovations in construction machinery. It covers sensor technology and embedded systems, achieving CO<sub>2</sub> neutrality and sustainability, integrating connected machines and networks, developing autonomous machinery, and applying the Industrial Internet of Things (IIoT) and collaborative devices. It aims to explore cutting-edge technologies, discuss environmental considerations, and examine the potential of intelligent and interconnected equipment in enhancing construction processes, productivity, and sustainability.

The last part of the book is about construction robotics. It explores the latest advancements in robotics applied to construction. It covers topics such as autonomous mobile robotics, construction robots and tools, computer vision and perception systems, using artificial intelligence (AI), cloud/edge computing, and human–robot collaboration in the construction industry. It explores the intersection of robotics, automation, and construction. It discusses the potential of intelligent machines, AI algorithms, and collaborative approaches to revolutionize construction processes, increase productivity, and enhance worker safety in the built environment.

These proceedings will be a valuable source of information and inspire us to continue working on innovative solutions to the construction industry's challenges. Together, we can revolutionize the construction world and make a difference in the future.

We hope you will be as enthusiastic about the contents of this book as we are.

October 2023

Johannes Fottner  
Dominik Matt  
Konrad Nübel

# Conference Organization

## Steering Committee

Johannes Fottner (Chair)	Technical University of Munich (TUM), TUM School of Engineering and Design, Chair of Materials Handling, Material Flow, Logistics, Garching near Munich, Germany
Konrad Nübel (Vice-Chair)	Technical University of Munich (TUM), TUM School of Engineering and Design, Chair for Construction Management, Munich, Germany
Dominik Matt	Free University of Bozen-Bolzano, Faculty of Engineering, Chair for Production Systems and Technologies, Head of Research Area "Industrial Engineering & Automation (IEA)", Bolzano, Bolzano, Italy

## Organizing Committee

Anne Fischer	Technical University of Munich (TUM), TUM School of Engineering and Design, Chair of Materials Handling, Material Flow, Logistics Garching near Munich, Germany
Charlotte Haid	Technical University of Munich (TUM), TUM School of Engineering and Design, Chair of Materials Handling, Material Flow, Logistics Garching near Munich, Germany
Alexander Schock-Schmidtke	Technical University of Munich (TUM), TUM School of Engineering and Design, Chair of Materials Handling, Material Flow, Logistics Garching near Munich, Germany
Susanne Höcht	Technical University of Munich (TUM), TUM School of Engineering and Design, Chair of Materials Handling, Material Flow, Logistics, Garching near Munich, Germany
Maximilian Schöberl	Technical University of Munich (TUM), TUM School of Engineering and Design, Chair of Materials Handling, Material Flow, Logistics Garching near Munich, Germany



# Contents

## Construction Logistics

Construction Logistics – An Underrated Topic and an Educational Gap in University Teaching .....	3
<i>Anne Fischer, Michael Schneider, Zhen Cai, Klaus Lipsmeier, Alexander Hochrein, and Johannes Fottner</i>	
A Journey to High Efficiency Construction (with Smart Logistics) .....	15
<i>Inga-Leena Schwager</i>	
A First Approach to a Semantic Process Model for Enabling an Information Flow for Reuse of Building Materials .....	23
<i>Victoria Jung, Christoph Heuer, and Sigrid Brell-Cokcan</i>	
Applicability of a Serious Game Framework for Construction Logistics .....	33
<i>Gábor Bohács and Bálint Bertalan</i>	
Smart Contract-Enabled Construction Claim Management in BIM and CDE-Enhanced Data Environment .....	40
<i>Xuling Ye, Ningshuang Zeng, Yan Liu, and Markus König</i>	
Automated Productivity Evaluation of Concreting Works: The Example of Concrete Pillar Production .....	48
<i>Fabian Pfitzner, Jonas Schlenger, and André Borrmann</i>	
Adaptive BIM/CIM for Digital Twinning of Automated Shotcreting Process ....	59
<i>Rehan Khan, Rahul Tomar, and Ahmed Ibrahim</i>	
Using Digital Models to Decarbonize a Production Site: A Case Study of Connecting the Building Model, Production Model and Energy Model .....	69
<i>Isabella Deininger, Bernd Koch, Ralph Bauknecht, Mathias Langhans, Christoph Falk, Andreas Trautmann, and Konrad Nübel</i>	

## Construction Equipment

Evaluation of Different IIoT Transmission Technologies for Connecting Light Construction Equipment in Outdoor Areas .....	79
<i>Adrian Josef Huber and Johannes Fottner</i>	

Investigation of Data Transmission Between Construction Machines and Attachment Tools via OPC UA Technology .....	89
<i>Kathrin Land, Birgit Vogel-Heuser, Marius Krüger, Jan-Kristof Chen, and Johannes Fottner</i>	
Activity Recognition for Attachments of Construction Machinery Using Decision Trees .....	97
<i>Marc Theobald and Felix Top</i>	
How is the Profession of Excavator Operator Changing? The Demands of Digitalization and Automation of Construction Machinery from the Operator’s Point of View .....	107
<i>Martin Starke, Volker Waurich, Marcel Schweder, Manuela Niethammer, and Frank Will</i>	
Introduction of an Assistant for Low-Code Programming of Hydraulic Components in Mobile Machines .....	115
<i>Eva-Maria Neumann, Fabian Haben, Marius Krüger, Timotheus Wieringa, and Birgit Vogel-Heuser</i>	
Decarbonizing Construction Material Supply Chains: An Innovative Approach to Intermodal Transportation .....	123
<i>Philipp Miklausch, Manuel Woschank, and Julia Heißenberger</i>	
Embedding RFID Tags into Modular Textile Floor Coverings and Integration in BIM .....	137
<i>Abduaziz Jurabojev, Sebastian Suess, Rüdiger Kern, and Joaquín Díaz</i>	
<b>Construction Robotics</b>	
Status Quo of Construction Robotics: Potentials, Applications and Challenges .....	149
<i>Christian Richter, Jan Kortmann, Janik Mischke, Frank Will, and Jens Otto</i>	
Levels of Digitalization for Construction Machinery on the Connected and Automated Construction Site .....	157
<i>Volker Waurich, Benjamin Beck, Jürgen Weber, and Frank Will</i>	
Synthetic Data Generation for the Enrichment of Civil Engineering Machine Data .....	166
<i>Marius Krüger, Birgit Vogel-Heuser, Dominik Hujo, Johanna Walch, Theresa Prinz, Daniel Pohl, Suhyun Cha, and Cornelia Kerausch</i>	

Advancing Construction Efficiency Through Collaborative Robotics:  
 A Scalable Multi-agent-Based Logistics Solution ..... 176  
*Dietmar Siegele, Julius Emig, Cinzia Slongo, and Dominik T. Matt*

Agent-Based Simulation Model for the Real-Time Evaluation of Tunnel  
 Boring Machines Using Deep Learning ..... 184  
*Yara Salloum, Elham Mahmoudi, and Markus König*

A BIM-Integrated Robotics Application for Color Spraying in Construction ... 194  
*Andrea Gagliardo, Simone Garbin, Michael Terzer, Dominik T. Matt,  
 and Andrea Giusti*

A Digital Twin Model for Advancing Construction Safety ..... 201  
*Jochen Teizer, Karsten W. Johansen, Carl L. Schultz, Kilian Speiser,  
 Kepeng Hong, and Olga Golovina*

**Author Index** ..... 213

# **Construction Logistics**



# Construction Logistics – An Underrated Topic and an Educational Gap in University Teaching

## Lecture Concept from the Course *Construction Logistics* at the Technical University of Munich (TUM)

Anne Fischer<sup>1</sup> (✉), Michael Schneider<sup>1</sup>, Zhen Cai<sup>1</sup>, Klaus Lipsmeier<sup>2</sup>,  
Alexander Hochrein<sup>2</sup>, and Johannes Fottner<sup>1</sup>

<sup>1</sup> Technical University Munich, Boltzmannstr. 15, 85748 Garching b. München, Germany  
anne.fischer@tum.de

<sup>2</sup> Ed. Züblin AG, Direktion Mitte, Europa-Allee 50, 60327 Frankfurt am Main, Germany

**Abstract.** This paper starts with a short introduction to the subject of construction logistics. It illuminates the differences between a high industry demand for skilled professionals for construction logistics tasks and the restrained offer of such courses in the academic environment. The contrast between construction logistics companies and the limited availability of related university courses backs them up. The authors suggest a lecture structure based on the “construction logistics” course at TUM, which combines theoretical sessions and a simulation part.

Further, the individual session headings are listed together with a brief content description. The study progress of the participants is evaluated via a group project derived from a real-world project. Besides a report of possible examination tasks, a short excursion toward the evaluation criteria is being made. In the end, limitations regarding the validity of course content depending on the region are proposed.

**Keywords:** Construction Logistics · University Teaching · Lecture concept

## 1 Introduction

### 1.1 Construction Logistics – What is It?

Without efficient construction logistics, it is not possible to succeed in achieving a trouble-free construction process [1]. Often underestimated, Günthner [1] shifts the construction industry’s focus to the importance of construction logistics: from a singular consideration of supply and disposal to a process-oriented logistics management, as in the stationary industry.

Per definition, construction logistics handles the mobilization and productivity of all required resources and equipment and ensures safe and high-quality working conditions on the site [2]. The aim of construction logistics, in general, can be summarized by removing non-value-adding activities to increase productivity and lower costs [3]. In today’s time, it should be emphasized that reducing environmental pollution is another goal, which Lipsmeier [4] was already able to show with a waste management approach.

Construction logistics can be divided into four main resorts (Fig. 1): (1) procurement logistics, (2) production logistics, (3) disposal logistics, and (4) information logistics. Whereas procurement logistics handles everything off-site, including supply chain management and traffic, production logistics handles the material and equipment flow. The disposal is treated separately above everything standing, the information logistics, managing all parties and their requirements. Voigtmann [3] emphasizes the interconnection between the individual tasks and their corresponding place of execution. For example, the implementation of sustainable logistics strategies, such as kitting or reusable pallets on-site, has a significant impact on the delivery (installation of hubs), the production (exact planning of required materials), and the disposal (additional pallet handling and storing) [5]. In addition, Gschwendtner et al. [5] note that the borders between the different areas can be fluid in practice, e.g., when the concrete mixer places concrete into formworks, the procurement and production processes merge.

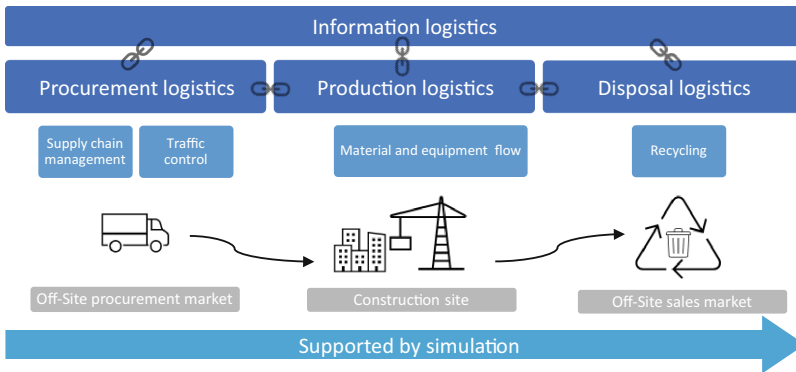

**Fig. 1.** Main tasks of construction logistics [3] (following [6–9])

Since the mid-2000s, different simulation approaches have increasingly supported the logistics process to face the complexity by modeling the dynamic development of the construction site and the various trades [10, 11]. However, simulation is not yet adopted in the construction industry [12]. Abdelmegid et al. [12] conclude that integrating simulation into construction engineering curricula is one of the critical enablers to overcoming its barriers.

The role of construction logistics is defined as an intersectional discipline throughout the project's lifecycle. It is an integral part of project process planning and project process control.

With the help of digitization, it has become a critical factor in today's construction projects. Thus, whether the potential will be used in the future arises. Will the universities take care of training young people who are sensitized and creative to find new solutions?

## 1.2 The Practical Relevance of Construction Logistics

Building upon the goal of construction logistics and the widely understood drive of every business-orientated company to minimize their costs and improve profit margins, it is no

surprise that almost every large construction company has a department for construction logistics.

Global players in the construction industry, such as Ed. Züblin AG, Wolff & Müller Holding GmbH & Co. KG, sto building group, or the mace group, offer services in construction logistics, often as part of an even broader scope under the term construction management. Figure 2 shows the range of available construction logistics tasks with exemplary regard to the portfolio of Ed. Züblin AG.



**Fig. 2.** Available construction logistics services in the industry, according to Ed. Züblin AG [13]

Furthermore, there exist specialized companies doing the construction logistics for large building projects as an external contractors or working as a consultant under challenging situations. Such companies are, for example, Wilson James, Zeppelin, and, in Germany, Ed. Züblin AG, for instance, BCL – building construction logistics, SiteLog GmbH, CPC Baulogistik GmbH, and CBB Construction Building Brandenburg GmbH. This leads to the inference of construction logistics having a high status when it comes to the practical realization of medium and large construction projects, which are realized in temporal and spatial confinement.

The fact that buildingSMART Germany, a non-profit competence network for an efficient and digital value-adding chain in the setting of building technologies [14], has established a roundtable with the topic of BIM (Building Information Modelling) and construction logistics enhances this statement even further [15].

### 1.3 Construction Logistics in Science and Teaching

To answer the question initially, we conducted an unstructured literature review to search for construction logistics courses in science and teaching. In sharp contrast to the high demand for construction logistics in real-world building projects, the academic teaching offer seems limited. Only a comparatively low number of universities worldwide have such a lecture in their portfolio. The most detailed courses on construction logistics are listed in Appendix Table 1. The last entries in this list show classes from the German-speaking Central European region, specially tailored to the needs of construction sites in this area.

Besides offering lectures from different universities around the world, only one professorship dealing exceptionally with construction logistics topics could be determined in the German-speaking part of Europe. Professor Michael Denzer at the University of Applied Sciences in Biberach, Germany. Significantly, one of the biggest German construction companies sponsors this professorship.

The courses teach theoretical basics about supply chain management, resource management, the characteristics of different process strategies, and lean construction. However, practical parts in the form of exercises and sample project simulations are less common. Only the lecture from Dr. Klaus Lipsmeier includes teaching in discrete-event simulation and student-performed reference calculations.

## 2 Exemplary Lecture at TUM

Due to the limited availability of lectures in construction logistics, the authors of this paper want to give a reference point for a possible curriculum and the corresponding examination concept according to the “Baulogistik” course by Klaus Lipsmeier from the Ed. Züblin AG at the Technical University Munich (TUM).

### 2.1 Basic Structure

The course mentioned above can be divided into two main parts: the theoretical teaching of basics with exemplary real-world projects and the practical simulation of the supply process regarding a specific site layout. The main content is based on the literature of Zimmermann [16], Ruhl et al. [17], HOAI [18], and Clausen [19].

**Basic Lessons with Theoretical Topics.** The main tasks of construction logistics inspire the curriculum according to Fig. 1 but try to teach the issues in a greater context. Therefore, introduction lessons and lectures on digitalization and lean construction are added. Figure 3 gives an overview of the individual studies on each topic. A more detailed description of each session can be found further down below.

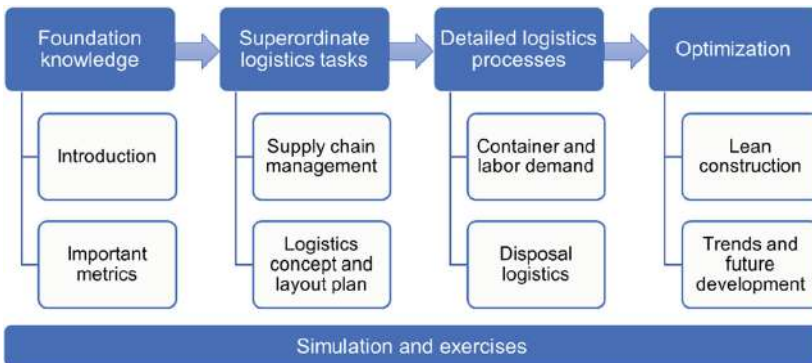

Fig. 3. Lecture concept of construction logistics at TUM

*Introduction to the Topic of Construction Logistics and Building Projects.* Besides a general overview of the different aspects of construction logistics, the students get to know the stakeholders of construction projects and the framework conditions of building projects. The block closes with a first insight into the topics of the following lessons and the construction logistics department’s placement inside a construction company.



*Essential Metrics in Construction Logistics.* This lecture at first provides a basic description of metrics and how they are generated. The second part shows crucial metrics in the context of building projects, such as the number of expected delivery units per trade and gross floor area (gross floor area: primary metric to compare building projects with different topologies, determined by the sum of the floor area of each level).

*Construction site Supply Chain Management.* Building upon the metrics from the previous block, the students learn how the supply chain develops over time in the different construction phases. In addition, varying mathematical modeling techniques for supply development and their ad- and disadvantages are explained. To further enhance understanding, an Excel sheet with blank calculations and graphical visualization of this lecture is given to the students.

*Development of an Appropriate Logistics Concept, Including the Layout Plan.* Starting with the analysis of the surrounding area near the site and the available transportation infrastructure, a first layout for the traffic route can be derived. A site layout plan can be sketched, including all necessary equipment, barriers, and material handling paths. The logistics concept is further detailed by selecting the optimal horizontal and vertical material transport concept.

*Container and Construction Laborer Development.* This lesson teaches the students how the demand for laborers changes with each construction phase. In addition, the required number of containers for accommodation, manager bureaus, and sanitary facilities is determined by a calculation key. The correct placement of the container, complying with all regulations, for example, allowed height and fire protection, and different container provision strategies, are also part of this lecture.

*Recycling and Waste Logistics.* The number of recycling containers is determined starting with the different waste fractions appearing on the construction site. A metric (depending on the building complexity level) is used to estimate the total amount of waste. The presentation of various waste collection strategies, ranging from trade self-organized to a circular economy approach, rounds up this lecture.

*Lean Construction Logistics.* After a short introduction to lean processes, the students learn the different waste types, such as unnecessary process steps or too large stocks. Furthermore, various tools used in real-world projects are presented, whose job is to enhance lean approach implementation. Examples of such devices are pocket maps with the site's layout or specially marked areas for material storage and recycling bins.

*Digital Trends and Future Development of Construction Logistics.* Besides the increasing importance of Building Information Modelling (BIM) and the live-online notification of delivery vehicles, tracking all sorts of parts is a rapidly developing trend. For example, the status and location of precast concrete elements from the manufacturing facility over the transport until the installation can be determined using hand scanners and QR codes on the component.

**Simulation and Exercises.** The theoretical lectures are accompanied by small example exercises, which the students can perform on the given Excel sheets. These enable the ability to study the influence of individual parameters such as phase schedule or daily

worktime on the construction site layout plan and the logistics concept. The exercises also serve the purpose of guiding the students towards a larger sample project and the examination. In this lecture, we used an actual construction project from Ed. Züblin AG, called “Meandris”, is located in Frankfurt am Main. As the students have already got to know the static calculation of the delivery traffic and other resources via the provided Excel sheets, the software package of Plant Simulation is used to add a dynamic approach to the construction logistics process (Software for simulating and modeling manufacturing and logistics by Siemens Tecnomatix [20]). The sessions build up quickly to a first model, starting with basic lessons on the various building blocks, like sources for vehicles, paths and loading stations (Fig. 4).



Fig. 4. 3D Plant Simulation model of an exemplary construction logistics layout

The model gets increasingly sophisticated by adding control functions in the form of methods and randomly generated delivery schedules. The students also learn to parameterize the individual parts according to the task by changing the settings or implementing disturbances, and they will also learn a primary use of the programming language in Plant Simulation. With the addition of a satellite picture of the construction site, the model can be made roughly to scale and therefore provides a realistic simulation of the superordinate logistics concepts (Fig. 5).

It would be possible to detail the model to any complexity level by adding a more finely divided structure. However, for a first experience with the program, the complexity should be kept at a lower level to focus on the essential message of the simulation. Such a goal could, for example, be the determination of the maximum size of a vehicle buffer or the achievable reduction in construction time by compressing the workload in a given site layout. Due to generating random delivery schedules and randomly appearing disturbances, different scenarios can be evaluated. This approach is intended to show how to convert period-based vital figures such as “vehicles per month” into more detailed point-in-time key statistics. The purpose is to convey the added value of a simulation

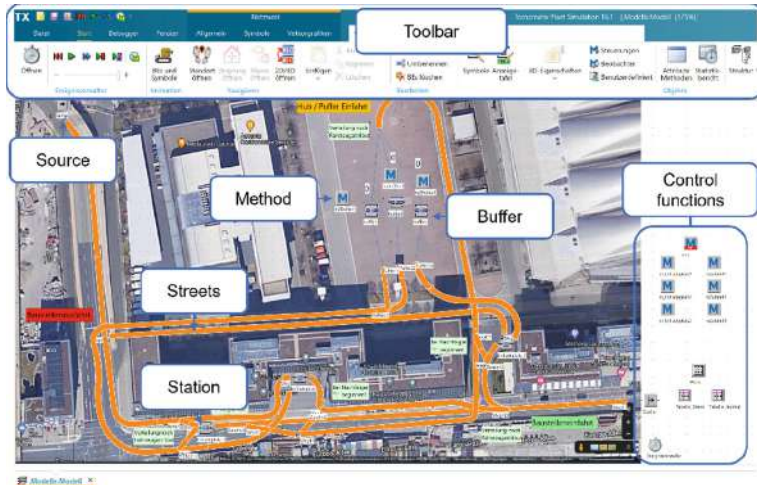

Fig. 5. Screenshot of a 2D Plant Simulation model (satellite picture by Google Maps)

through the possibility of using more detailed characteristic values and their interaction as a function of time.

To prepare the student as best as possible for the final examination, it should be considered to provide a homework task containing an exercise simulation project. Experiences have shown that this homework, combined with weekly Q&A sessions with the lecturer, receives excellent student feedback and is among the most effective learning techniques, according to the participants. Due to the deep connection with real-world applications, it is also possible to supplement the course with guest lectures held by industry professionals or other university professors.

## 2.2 Real-World Examination Project for Advanced Understanding

**General Concept.** The idea of the examination project is to give a group of two or three students a typical construction logistics task out of a running or already completed real-world project. This project should be of similar or slightly higher difficulty than the exercises of lecture and simulation. If possible, the construction site may be visited together with the students to provide a better understanding of the examination tasks.

**Required Tasks.** As a final submission, the students hand in a report in which they describe their solution approach as well as their execution of the tasks and the corresponding conclusions, together with the presentation slides for the colloquium.

The individual tasks covered in the report may be:

- Sketching of a construction site set-up plan under the given circumstances;
- Deriving logistics metrics upon empirical data;
- Calculating a static reference construction schedule for supply, personnel development, and waste emergence with the Excel sheets;
- Evaluating criteria for a possible reduction in construction time;

- Creating a to-scale model in Plant Simulation with full parameterization;
- Generating different random delivery schedules;
- Determining the required buffer capacities;
- Adopting the simulation to accomplish compressed construction time;
- Concluding the changing requirements for regular and shortened construction time;
- Summarizing the resulting aspects in a short overview.

**Evaluation Criteria.** A weighted average of the quality of the written report and the colloquium is taken to evaluate the examination project. First, it should be checked if all given circumstances were implemented correctly into the simulation and Excel sheets. Further, the individual assumptions for open questions are evaluated according to their practicality and meaningfulness. Besides the pure content of the report, a logical structure, adequate language, and a clean format, as well as a scientific reference style should be considered for evaluation. The simulation model can be checked for small details like commented control functions and visual clarity beyond pure functionality.

In the colloquium, particular focus should lay on the condensation of the determined results in a short format. The presentation slides have to meet the same criteria as the written report. The oral presentation should be clear to understand, and the parts should be equally matched between the team members.

### 3 Conclusion

#### 3.1 Needs to Teach Construction Logistics for Real-World Projects

In an ever-increasing search to maximize output with minimal resources and the drive for the most significant profit margins in all sorts of projects, construction logistics is the optimal tool to reach these goals. The high industry spread of departments only for construction logistics inevitably leads to increasing demand for highly specialized professionals. And where to better train such future engineers as in universities? With a course concept highly influenced by real-world construction projects and the lifelong experience of lecturers from this field, it is ensured that students get a very realistic insight into the basics of construction logistics.

The course description in this paper should encourage institutes and professors worldwide to set up their lectures on construction logistics. Resulting in balancing development between a high industry demand and an, as today, still underrated representation of construction logistics in the academic curriculum.

#### 3.2 Limitations of the Lecture Concept

The most significant limitation in the presented lecture concept lay in the fact that the local regulations, techniques, available materials, and philosophy regarding construction vary vastly between countries and even more between the different regions worldwide. It is, therefore, necessary to adapt the content of the course to the area-specific requirements in which it is taught. Native experts may be able to help in the customizing process to offer the most relevant academic education for later implementing real-world projects. In

addition, mastering a programming language is essential for creating complex simulation models. If the students have no previous knowledge, only the essential functions of Plant Simulation can be used.

## Appendix

**Table 1.** Available courses on construction logistics

University	Location	Department	Lecturer	Course name	Content overview
George Brown College	Toronto, Canada	Angelo DelZotto School of Construction Management	Tom Stephenson	Construction site management, supervision and [21, 22]	Resource management; Lean construction; Site Layout
Auckland University of Technology	Auckland, New Zealand	School of Engineering Computer and Mathematical Sciences	–	Supply chain management for construction [23]	Construction logistics; Modelling of construction sites
Halmstad University	Halmstad, Sweden	School of Business, Innovation and Sustainability	–	Industrialized building and construction logistics [24]	Construction supply chain; Lean construction; Logistics models
Technical University Graz	Graz, Austria	Faculty of Civil Engineering	Christian Hofstadter	Baublaufplanung und Logistik [Constr. scheduling and logistics] [25]	Construction logistics; Waste management
Univ. of Natural Resources and Life Sc.	Vienna, Austria	Institute of Production and Logistics	Manfred Gronalt and Benjamin Kromoser	Construction logistics [26]	Resource management; Access management; Consolidation centres
University of Applied Sciences Mainz	Mainz, Germany	School of Technology	Axel Freiboth	Digitalisierung in der Bauwirtschaft [digitalization in construction industry] [27]	BIM, Digitalization, construction logistics
Technical University Hamburg	Hamburg, Germany	Institute for Transport Planning and Logistics	Heike Flämig	Baulogistik und Projektmanagement [Construction logistics and project management] [28]	Internal and external construction logistics; Supply and waste chain

(continued)

**Table 1.** (continued)

University	Location	Department	Lecturer	Course name	Content overview
Technical University of Munich	Munich, Germany	Chair of Materials Handling, Material Flow, Logistics	Klaus Lipsmeier	Baulogistik [Construction logistics] [29]	see above
Beuth Univ. for Technology	Berlin, Germany	–	Klaus Lipsmeier	Baulogistik [Construction logistics]	Introduction; Metrics; Supply chain mgmt.; Logistics concepts and layout plan; Container and labour demand; Disposal mgmt.; Lean; Future trends; Simulation
University of Applied Sciences Biberach	Biberach, Germany	Research professorship in construction logistics, sponsored by Wolff & Müller	Michael Denzer	Baulogistik [Construction logistics] 1 & 2 [30, 31]	Construction logistics services, digitalization, and contracting

## References

1. Günthner, W.A. (ed.): Logistik in der Bauwirtschaft [Logistics in the construction industry]: Status quo, Handlungsfelder, Trends und Strategien; Studie. Bayern Innovativ - Gesellschaft für Innovation und Wissenstransfer [u.a.], Nürnberg u.a (2008)
2. Guffond, J.-L., Leconte, G.: Developing construction logistics management: the French experience. *Constr. Manag. Econ.* **18**, 679–687 (2000). <https://doi.org/10.1080/014461900414736>
3. Voigtmann, J.K.: Simulation baulogistischer Prozesse im Ausbau [Simulation of construction logistics processes in finishing]. Dissertation, Bauhaus-Universität Weimar (2014)
4. Lipsmeier, K.: Abfallkennzahlen für Neubauleistungen im Hochbau [Waste indicators for new construction services in building construction]: Hochbaukonstruktionen und Neubauvorhaben im Hochbau nach abfallwirtschaftlichen Gesichtspunkten. Dissertation, Technische Universität Dresden (2004)
5. Gschwendtner, C., Fischer, A., Fottner, J., et al.: Evaluating supply-and reverse logistics alternatives in building construction using simulation. In: 2021 Winter Simulation Conference (WSC), pp. 1–12. IEEE (2021)
6. Boenert, L., Blömeke, M.: Kostensenkung durch ein zentrales Logistikmanagement [Cost reduction through central logistics management]. In: Clausen, U. (ed.) Baulogistik-Konzepte für eine bessere Ver- und Entsorgung im Bauwesen, pp. 29–41 (2006)
7. Girmscheid, G., Etter, S.: Zentrales Logistikmanagement auf innerstädtischen Baustellen [Central logistics management on inner-city construction sites]: operative Umsetzung. *Bauingenieur* **87**(11), 470–479 (2012)
8. Krauß, S.: Die Baulogistik in der schlüsselfertigen Ausführung [Construction logistics in turnkey execution]: ein Modell für die systematische Entwicklung projekt- und fertigungsspezifischer Logistikprozesse. In: Bauwerk (2005)

9. Schach, R., Schubert, N.: Logistik im Bauwesen [Logistics in construction]. In: Wissenschaftliche Zeitschrift der Technischen Universität Dresden, Heft 1 - 2, pp. 59–63 (2009)
10. König, M., Beißert, U., Bargstaedt, H.-J.: Visual simulation - an appropriate approach to support execution planning in building engineering. In: 7th International Conference on Construction Applications of Virtual Reality, pp. 189–197 (2007)
11. Weber, J.: Simulation von Logistikprozessen auf Baustellen auf Basis von 3D-CAD Daten [Simulation of logistics processes on construction sites based on 3D CAD data]. Dissertation, Universität Dortmund (2007)
12. Abdelmegid, M.A., González, V.A., Poshdar, M., et al.: Barriers to adopting simulation modelling in construction industry. *Autom. Constr.* **111**, 103046 (2020). <https://doi.org/10.1016/j.autcon.2019.103046>
13. Züblin, A.G. (ed.): Broschüre Züblin Baulogistik (2021). Accessed 23 Mar 2023. [https://www.zueblin.de/databases/internet/\\_public/files30.nsf/SearchView/7B36062B4DB1987BC12587040076B861/\\$File/A4\\_Broschuere\\_Zueblin\\_Baulogistik\\_Key\\_Visual\\_20210204\\_INT ERAKTIV\\_neu.pdf](https://www.zueblin.de/databases/internet/_public/files30.nsf/SearchView/7B36062B4DB1987BC12587040076B861/$File/A4_Broschuere_Zueblin_Baulogistik_Key_Visual_20210204_INT ERAKTIV_neu.pdf)
14. buildingSMART Deutschland e. V.: This is buildingSMART Germany (2021). <https://www.buildingsmart.de/sites/default/files/2021-07/buildingSMART%20Deutschland%202021.pdf>. Accessed 23 Mar 2023
15. Homepage buildingSMART roundtables. <http://www.bsde-tech.de/mitarbeiten/roundtable/>. Accessed 23 Mar 2023
16. Zimmermann, J. (ed.): Baulogistik [Construction logistics]: Innovationspotenziale für die Bauwirtschaft. Schriftenreihe/Lehrstuhl für Bauprozessmanagement und Immobilienentwicklung, Technische Universität München, vol 22. Lehrstuhl Bauprozessmanagement und Immobilienentwicklung TUM, München (2009)
17. Ruhl, F., Motzko, C., Lutz, P.: Baulogistikplanung [Construction logistics planning]: Schnelleinstieg für Bauherren, Architekten und Fachplaner. SpringerLink Bücher. Springer, Wiesbaden (2018)
18. Ausschuss der Verbände und Kammern der Ingenieure und Architekten für die Honorarordnung. Leistungen für Baulogistik: Leistungsbild und Honorierung, 1. Aufl., Stand: März 2011. Schriftenreihe des AHO, Nr. 25. Bundesanzeiger-Verl., Köln (2011)
19. Clausen, U. (ed.): Baulogistik - Konzepte für eine bessere Ver- und Entsorgung im Bauwesen [Construction logistics - concepts for better supply and disposal in the construction industry]: Beiträge der BauLog 2004, Fraunhofer IML. Logistik, Verkehr und Umwelt. Verl. Praxiswissen, Dortmund (2006)
20. SIEMENS Digital Industries Software Tecnomatix Plant Simulation. <https://plm.sw.siemens.com/de-DE/tecnomatix/products/plant-simulation-software/>. Accessed 28 Mar 2023
21. Course Construction Site Management, Supervision and Inspection - George Brown College. <https://commspdfservice.azurewebsites.net/CreateOutline.ashx?coursecode=BLDG2045&courseversion=&academicyearid=110&academicyearname=2020-2021&collegeid=9&collegeshortname=georgebrown&collegename=George%20Brown%20College>. Accessed 20 Mar 2023
22. Playlist - Lecture Recordings: Construction Site Management, Supervision and Inspection 2020/2021. <https://www.youtube.com/playlist?list=PL-MQNpO8Wb7DV1w8gU5dqg8YLYPg1IZo4>. Accessed 20 Mar 2023
23. Homepage Course Construction Supply Chain Management - Auckland University. <https://courseoutline.auckland.ac.nz/dco/course/CIVIL/707/1223>. Accessed 20 Mar 2023
24. Homepage Course Industrialized Building and Construction Logistics - Halmstad University. <https://www.hh.se/english/education/courses-for-exchange-students/industrialized-building-and-construction-logistics.html>. Accessed 20 Mar 2023

25. Homepage Course Construction Logistics - TU Graz. [https://online.tugraz.at/tug\\_online/wbLv.wbShowLVDetail?pStpSpNr=234931&pSpracheNr=2&pMUISuche=FALSE](https://online.tugraz.at/tug_online/wbLv.wbShowLVDetail?pStpSpNr=234931&pSpracheNr=2&pMUISuche=FALSE). Accessed 29 Mar 2023
26. Homepage Institute of Production and Logistics. <https://boku.ac.at/en/wiso/pwl/courses#/en/lehrveranstaltungen/lva/303462>. Accessed 29 Mar 2023
27. Freiboth, A.: Modulbeschreibung Digitalisierung in der Bauwirtschaft [Module description Digitalization in the construction industry] (2022). [https://www.hs-mainz.de/fileadmin/Techchnik/fr\\_bauingenieurwesen/modulhandbuch/Modulhandbu\\_\\_cher\\_MaBau\\_Neuste\\_Version.pdf](https://www.hs-mainz.de/fileadmin/Techchnik/fr_bauingenieurwesen/modulhandbuch/Modulhandbu__cher_MaBau_Neuste_Version.pdf). Accessed 27 Apr 2023
28. Modulhandbuch für Logistik, Infrastruktur und Mobilität - TU Hamburg. [https://studienplane.tuhh.de/po/W/mhb\\_LIMMS\\_kh\\_w22\\_von\\_20220621\\_v\\_0\\_de.pdf](https://studienplane.tuhh.de/po/W/mhb_LIMMS_kh_w22_von_20220621_v_0_de.pdf). Accessed 20 Mar 2023
29. Chair of Materials Handling, Material Flow, Logistics. <https://www.mec.ed.tum.de/en/fml/courses/lectures-and-university-internships/>. Accessed 29 Mar 2023
30. Professorship Construction Logistics at University of Applied Sciences Biberach. <https://www.hochschule-biberach.de/forschungsprofessur-fuer-baulogistik-hochschule-biberach-setzt-neue-akzente>. Accessed 22 Mar 2023
31. University of Applied Sciences Biberach: Module manual: Bachelor Degree Program. Construction Project Management/Civil Engineering (2021). [https://www.hochschule-biberach.de/sites/default/files/medien/dokumente/BP\\_SPO8\\_MHB\\_Modulhandbuch\\_%28Stand%202021-06-28\\_Rev08%29.pdf](https://www.hochschule-biberach.de/sites/default/files/medien/dokumente/BP_SPO8_MHB_Modulhandbuch_%28Stand%202021-06-28_Rev08%29.pdf)





# A Journey to High Efficiency Construction (with Smart Logistics)

## The Construction Site is Experiencing an Almost Revolutionary Time Due to the Networking of the Systems

Inga-Leena Schwager<sup>(✉)</sup>

Amberg Loglay AG, Räfelstrasse 25, 8045 Zurich, Switzerland  
ischwager@ambergloglay.com

**Abstract.** Digitalization in construction logistics ensures greater efficiency.

The starting point of the journey is Bruno Latour's concept: "On not joining the dots" [1] - or as we claim "on finally joining the dots" - according to which everything tangible and intangible is connected. And connecting the disciplines through data-driven logistics is what this session is all about.

If the key to success is to eliminate redundancies and duplications and to overcome the boundaries within the entire value chain, which in turn means linking all available information and making it universally accessible to determine the most efficient production process - then smart logistics is that key. Data-driven logistics creates a model-based production process (BIM2LOG a "digital twin") that leverages the "invisible" spaces off-site, which are provided in the form of data and "materialize" on-site.

If smart logistics is the key to success on the construction site and is itself based on a smart city infrastructure, then this infrastructure is critical to the success of a project.

In this paper we will analyze two dimensions in construction logistics: the dimension of time (joining the project stages) from early planning to execution and the dimension of space (joining the construction supply chain) from a consolidation center to the very production on site.

**Keywords:** Data-Driven Logistics · BIM2LOG · Construction Supply Chain

## 1 Introduction

"On not joining the dots", Bruno Latour's theory [1] claims that all tangible and intangible things are interconnected; interdependent and conditional. Using this theory as a catalyst; represents the incapacity to join all information as such networking of the systems and their difficulties is the central topic in this report.

Networking of the systems, interdisciplinary excellence, joining the dots, collaboration, portfolio thinking, ecosystems represent an infinite list of synonyms to overcome our industry failure. We are talking about the construction industry and affiliated segments and the transition into a digital époque.

The construction industry is not only facing rapid growth and endless demand right now, but it is also suffering highly from inefficiency, corruption and low profits and facing a radical hyper development and digitization [2].

This research will address all three of the challenges listed above as the tangible campus and the intangible issues by addressing everything invisible but holding the system together such as moving goods or the space they use to move around. Common problem in each project in this industry is its highly complex nature. Our campus is comprehensive, complicated, and complex and we struggle to manage it. Computer systems now can help to enhance our management here and there; the question however is, if exactly these systems are just adding more layers of complexity?

The goal is to visualize a construction logistics network and go on a journey within the dimensions of time, space and the stakeholders.

Referring to Bruno Latour, the methodology is going to be highly interdisciplinary research, using three categories: speculative, empirical, artistic.

The interdisciplinary question behind “on not joining the dots” appears in every moment when “construction systems” collide. The question is, if this is the remaining fact or on the contrary something that has never been a fact but instead systems and dots that always correlate?

## 2 Research and Methodology

Given the complexity of connecting or ignoring seemingly unrelated information in this inquiry, the research methodology of breaking down disciplinary barriers has been adopted.

It serves as an experiment, an attempt to bring the “invisible” to life through imaginative and interpretive means. The report aims to tap into the creative realm of speculative provocation, the visual world of artistic imagery, and the realm of hard data to achieve its objectives.

The approach combines factual information with emotional spontaneity, stimulating creativity and dynamic thought in the reader. It also serves as an opportunity for personal introspection, pushing one’s analytical boundaries and examining individual limits. By following Bruno Latour’s analogy, we will draw parallels to our very own industry.

*Secondary research completed:*

- Random collection of existing relevant publications and frameworks that include philosophy, networking, change management, construction logistics data

*Primary research completed:*

- Research and Feedback of my experiences within my project and team works in past and present real life cases
- Experiences with our products and services and their application within our client projects

This report follows a series of analytics, reviewed and referenced herein, I performed in previous studies and builds onto them. This analysis aims to link my work for Amberg Loglay AG with my personal interdisciplinary venture into the fields of philosophy, science and art.

### 3 Dysfunctional Systems in Construction

In this chapter we will introduce three dysfunctional systems that will serve as the context of this inquiry, which we aim to link together in later chapters. Section 3.1 how living in a silo mentality is hindering collaboration and digital transformation, Sect. 3.2 how certain perspectives are invisible spaces in our (smart) cities that we can use to enhance mobility on site, Sect. 3.3 transition or paradigm of a logical system colliding with a human-based system.

#### 3.1 Living in a Silo (What is a Silo?)

To save costs, prefabrication, modularisation, and standardisation of planning and production processes are the go-to strategies that people often resort to. A beautiful concept is touted as the future of supply chains: a seamless string of information-infused elements (Big Data) assembled by a robotic hand. The key to realizing this dream is collaboration (BIM).

Despite yearning for a saviour, the industry remains anchored to its conventional work style, fostering a silo mentality. BIM, Big Data, and Modularisation are all implemented in isolation, with each silo employing its own code and models—curtailed by hierarchical restrictions, contractual obligations, and antiquated customs. Silo thinking, duplication and poor contracting practices make the sector extremely inefficient.

This phenomenon extends from the macro level (Sect. 4.1) to the micro level (Sect. 4.2). For example, each asset is moved several times on site before it is actually installed resulting in huge losses each time. We want to find out why silos resist against collaboration and the BIM ideology [3]?

#### 3.2 Everything is a Perspective (What is Tangible and What is Intangible?)

The smart city can help us to review separation and layering of our urban structures through a new lens. Urban spaces, architecture, traffic, energy and people will be more and more connected with each other through data and information sharing. This makes our daily routines more efficient and faster. What we are not aware of, that more efficiency will free up space and time; resources that we call the “invisible space” [3].

Logistics too, is per se invisible since it is everything that is moving. When visualizing logistics through time and space; we like to highlight the three dimensions developed by M. Grieves and J. Vickers *into a concept model of the digital twin, which consists of three main parts: the physical products in “real space”, the virtual or digital products in the “virtual space” and the data and information connections that connect the two* [4].

The Audi Urban Future Vision Initiative [5] displays how autonomous driving systems frees up valuable space in urban areas by using a piloted parking system to move and park cars without their driver, displaying beautifully “invisible” recovered space.

The use of smart logistics, data, and BIM technology on construction sites is paramount, but what about leveraging the full supply chain? Can we utilize the information provided by smart cities to enable large-scale construction projects from start to

finish? We envision a future where construction sites are integrated into a smart logistics network, with a seamless connection to the city's data and infrastructure. This will revolutionize the construction industry, replacing traditional, isolated construction sites with a fully integrated and connected construction network. As such the invisible space will grant relief to current congestion in cities.

### 3.3 Part-Whole Paradigm (What is a Network?)

Paul Baran one of the inventors of the internet *“envisioned a network of unmanned nodes that would act as switches, routing information from one node to another to their final destinations. Baran suggested there were three possible architectures for such a network —centralized, decentralized, and distributed”* [6]. Our aim is to create a perfectly distributed logistics network to allow for “perfect switching” between material flow on and off site and “flexibility” to react to sudden changes.

The biggest challenge when networking systems however is the part/whole problem. *The part/whole does not work for organisms: they imply overlapping and penetrable entities* [1]. Recalling Bruno Latour's hint of Lovelock's argument [1], *that all entities are selfish, but the boundaries of the selves cannot be determined*, we believe that it is paramount to be aware of this fact. To him the grey zone between self and non-self is the “critical zone”. In our case the critical zones exactly appear in the vacuum between the silos, between space and time. How do we assemble all these kinds of entities, when the part and whole cannot be physically determined? Emphasized by Scott Gilbert, who argues: a *“symbiotic view of life, we have never been individuals”* [7], meaning that entities cannot be determined in isolation and will always involve unexpected dynamics through their overlapping. As such we assume that the thing is logical and mathematical (a perfect system) and the tribe is non-logical and liquid (a chaotic system).

## 4 End-to-End Supply Chain for Construction Sites

Our vision is to develop an end-to-end supply chain networked across a big data space. This means that the entire journey of the material to the construction site has been recorded and its best route there has been determined in advance. This journey takes us through the city (macro space) and onto the site (micro lens) exploring where collaboration, smart city space and human-based network design meet (Sect. 3).

### 4.1 Macro Lens – Smart City, Urbanisation, Megacities

Construction plays a huge role in the development of our Smart Cities: as one of the creators of urban spaces; as one of the facilitators to local authorities; as one of the providers of heavy-duty tools to meet digital grids [3].

By 2030 two thirds of the global population will be living in urban areas with most of them in Megacities if not even Gigacities (population above 50 Million) [9].

With the rapid urbanization come specific challenges: the new organisation of transport, energy, culture, and economies; in short: a reinvented city-infrastructure.

The term “Smart City” is mentioned often, but what does it truly signify? Rather than accepting a universal definition, we can develop our own. According to a Swiss Working Group [10], the Smart City will be a constantly evolving environment - a “canvas of transformation” that evolves in perpetuity. It isn’t solely a physical location; it’s a living space. Developing a home in an unpredictable climate necessitates the preservation of agility and adaptability. This will develop into a system that is always learning, with technology serving as the conduit for creating intelligent living quarters. Again, we are dealing with “critical zones” (Sect. 3.3).

#### 4.2 Micro Lens – Time, Quality, Cost Problems on Site

Metrics in the construction sector have been in negative trend for many years. Construction is lacking behind GDP growth by 30% over the past 20 years with an average profit margin of around 1%–2% or even lower [11]. Construction runs over budget by 80% and by time over 20%. Construction is one of the least digitalized industries [11] due to the pure multitude of factors that it needs to incorporate and most of all the diversity of its human capital.

Today, up to 50% is planned and 50% executed ad-hoc on sites in the operational business. This leads to many inconsistencies and discrepancies.

By linking the BIM Modell to the construction schedule can increase the visibility and understanding of time. By linking the site to its surrounding and ultimately to its production place can increase use of invisible space. By centralizing all logistical elements into one hand will reduce discrepancies in staff.

## 5 Networking of the Systems

So where do we start? First, let’s just start by looking closely, because processes can already be improved by 30% if we just look. Digitalization is due to happen not only because it is the future but also because construction needs accelerated efficiency.

### 5.1 Dimensions of Construction Logistics – Urbanising Building

The distributed world of construction silos according to the dimensions we operate in are as follows (Figs. 1, 2 and 3):

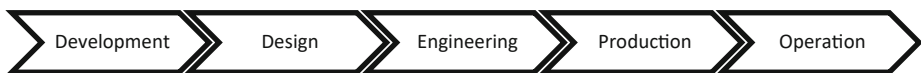

**Fig. 1.** Dimension of Time – Planning and execution stages in a construction project



**Fig. 2.** Dimension of Disciplines - Stakeholders in a construction project

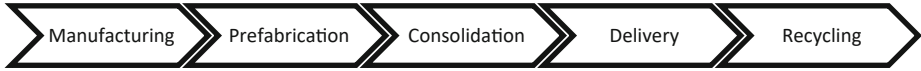

**Fig. 3.** Dimension of Space – Construction Supply Chain

## 5.2 Dimension of Space – Linking Transport to the Site

If 500 suppliers deliver individually, this leads to congestion on and in front of the construction site, and there is also a lack of space. We leave the site and use external hubs to repackage and streamline deliveries with the aim of reducing traffic (vehicles, cargo, people) to and from the site.

We take a digital model of the city, import it into a database and add all available city information such as traffic flow. Off-site hubs and construction sites are now connected through data on one platform.

We consolidate the deliveries in a central booking system (CLM)<sup>1</sup>. Each truck gets a delivery time, space and in some cases even personnel and equipment for unloading. The central booking system issues a delivery bill with QR code, which is scanned upon delivery. The pallet is equipped with the delivery bill. When the pallet arrives at the construction site, it is moved in the specially booked and scheduled equipment. The QR code is used for quick identification in the mobile app. The material thus arrives at the right place at the right time.

## 5.3 Dimension of Time – Linking Construction Schedules to Material Flow

How do we know when the right delivery has to arrive?

We started with comprehensive process analysis and planning to understand the complexities of large-scale projects and customize its smart logistics. We linked BIM data and schedules (4D planning) to the construction process and collected datasets from previous workflows. This enables us to identify, simulate and mitigate risks, weaknesses and bottlenecks in advance.

BIM2LOG<sup>2</sup> brings together the BIM model with the schedule and calculates the ideal delivery frequency. The BIM Model indicates who is delivering how much and where. This also generates a space management (LIM)<sup>3</sup> and optimal utilisation of transport streams according to the timeframe.

<sup>1</sup> CLM – Construction Logistics Management, Application of Amberg Loglay AG.

<sup>2</sup> BIM2LOG - Building Information Modeling to Logistics, model-based logistics management.

<sup>3</sup> LIM – Logistics Insights Management, Application of Amberg Loglay AG.

## 5.4 Dimension of Stakeholders – Linking the Production Value Chain

Smart Logistics is supported by logistics teams on site and at the hub ensuring material flow, equipment, transport and recycling are coordinated and executed according to plan. They are supported by IoT solutions, such as sensors that monitor elevator usage and waste disposal volumes, for maximum efficiency.

Imagine that 500 employees all bring their own equipment to the floor and quickly the area to be built on is full. Each contractor organizes himself and the area is used inefficiently. We measured how much equipment (assets) is in use and how their utilization rate is. Leveraging from the driving profile, we now use a central vehicle pool and booking system (CLM).<sup>4</sup>

Imagine you are building a high-rise building with about 500 employees who all have to get their material and themselves to all floors at the same time at 7:00 am with limited to zero lifts. How can we manage people transportation? We attached a sensor to a lift and measured what the profile had looked like. Using pro-active lift management and forecasting, we can reduce travel times by 50%.

## 6 Facing the Dilemma with Constant Change

Coming back to the initial thought of the incapacity to join all the dots; If we have learned something, that this dilemma is true. We suffer from three dysfunctional systems: 1) BIM and collaboration versus silos, 2) using invisible resources versus congested spaces in cities, 3) targeting the part whole paradigm of machine-based versus human-based networks.

We can pick any current book or guideline on new working ways, BIM, Lean or IPD, or Marketing and Corporate Design, they all emphasize agility, innovation, change, flexibility. Fundamentals we struggle to manage.

However, if we shift perspective or set a different goal to our future construction processes, we can reshuffle our destiny. For this, we need to be honest to ourselves. Rather than shouting out quick wins and solutions, it is paramount to acknowledge that our preferences are different, that in fact, we might just be the opposite. Being aware of the contradictions instead of ignoring them, we better make them part of construction and the transition process. *“We need to ask ourselves if the elevated technological content of design processes is translated only into doing old things in a new way, or if the digital process itself is becoming a fundamental quality of the architectural project”* [12].

### 6.1 Our Playground – Putting Ourselves into the Heart of the Process

We have chosen to target our industry challenges and dilemma likewise on different levels (Sect. 5.1) by putting ourselves into the heart of the process and at the same time with the courage to face also failure. We are always: *Data-influenced; Experimental, Customer-centric, Entrepreneurial, Iterative, Questioning assumptions* [13]. Experimentation, distribution and differentiation leads us to grow our network beyond some

---

<sup>4</sup> CLM – Construction Logistics Management, Application of Amberg Loglay AG.

of the dimensions. We fully support the idea of “Permanent Beta Modular Design – a process in constant change and interaction with the target groups [14].

We see each day as a new creative process, a process of adapting workflows, stakeholders and materials. Our predictive logistics learning system can connect construction dynamics with city dynamics daily to achieve peak performance and ensure on-time arrivals.

## References

1. Latour, B.: Bruno latour on not joining the dots Radcliffe institute. On not joining the dots (2016). <https://www.youtube.com/watch?v=wTvbK10ABPI>. Accessed 16 Apr 2023
2. Barbosa, F., Woetzel, J., Mischke, J., et al.: Reinventing construction through a productivity revolution. <https://www.mckinsey.com>. <https://www.mckinsey.com/capabilities/operations/our-insights/reinventing-construction-through-a-productivity-revolution>. Accessed 21 Jul 2023
3. Schwager, I.-L.: Why digitise underground space and make it part of architectural design? In: Swiss Tunnel Congress 2020: Fachtagung für Untertagebau, 3 June 2020, pp. 236–247. FGU Fachgruppe für Untertagebau, Zürich (2020)
4. Grieves, M.: Digital twin: manufacturing excellence through virtual factory replication (2015)
5. Audi, A.G.: Urban Future Initiative. Audi Media Center (2015). <https://www.audi-mediacenter.com/en/search?query=Audi+Urban+Future+Initiative+%E2%80%93+Urban+Solutions&type=image>. Accessed 16 Apr 2023
6. Maltoni, V.: How Everything is connected to everything else and what it means. Conversation Agent (2006). <https://www.conversationagent.com/2016/05/how-everything-is-connected-to-everything-else-and-what-it-means.html>. Accessed 16 Apr 2023
7. Gilbert, S.F., Sapp, J., Tauber, A.I.: A symbiotic view of life: we have never been individuals. *Q. Rev. Biol.* **87**, 325–341 (2012). <https://doi.org/10.1086/668166>
8. Baran, P.: On Distributed Communications: V. History, Alternative Approaches, and Comparisons. RAND Corporation (1964)
9. Allianz, S.E.: The megacity of the future is smart. Allianz.com (2015). <https://www.allianz.com/en/press/news/studies/151130-the-megacity-of-the-future-is-smart.html>. Accessed 21 Jul 2023
10. Schwehr, P., Keikut, F., Ruch, R.: Working paper, smart cities, Versuch einer Auslegeordnung (2018)
11. Agarwal, R., Chandrasekaran, S., Sridhar, M.: Imagining construction’s digital future. mckinsey.com (2016). <https://www.mckinsey.com/capabilities/operations/our-insights/reinventing-construction-through-a-productivity-revolution>. Accessed 16 Apr 2023
12. Orlandi, M.: Data-informed design. Allegato in omaggio DOMUS Green Design Domus – mensile, vol. 1016, p. 23 (2017)
13. Bland, D.J., Osterwalder, A., Smith, A., et al.: Testing business ideas: dieses Buch ist Ihr Versuchslabor für schnelle Experimente: nutzen Sie die 44 Experimente, um Ihren Weg zum Wachstum zu finden: mit kleinem Einsatz durch schnelle Experimente zu großen Gewinnen! Strategyzer Reihe. Campus Verlag, Frankfurt New York (2020)
14. Rädicker, J.: Richtig ist das neue Schön. In: Beyrow, M., Kiedaisch, P., Klett, B. (eds.) Corporate Identity & Corporate Design 4.0: das Kompendium, Komplette Neuauflage. avedition, Stuttgart, p. 45 (2018)





# A First Approach to a Semantic Process Model for Enabling an Information Flow for Reuse of Building Materials

Victoria Jung<sup>(✉)</sup> , Christoph Heuer , and Sigrid Brell-Cokcan 

Chair of Individualized Production (IP), RWTH Aachen University, Campus-Boulevard 30,  
52074 Aachen, Germany

{jung, heuer, brell-cokcan}@ip.rwth-aachen.de

**Abstract.** As climate change intensifies and materials become scarcer, there is increasing pressure on the construction industry to find more sustainable solutions for controlled deconstruction and the recovery of building components as a future source of secondary building products. The technical implementation for a robot-assisted deconstruction process of concrete elements is already being investigated. At present, however, there is no continuous flow of information between the data of existing buildings, from which components are removed, and new buildings, into which recovered components are integrated. For the testing process and the approval of the components for reuse, it is crucial to know where the elements come from, how they have been constructed and in which context they are to be reused afterwards. The establishment of a semantic process model to extend the Building Information Model (BIM) is the basis for connecting the information from the different buildings and intermediate inspection processes to enable the approval of the components.

Based on existing achievements, a semantic process model was conceptualised, which enables a linking of the information of the building component along the entire process chain. The process model not only connects the information of the existing building and the new building, but also enables the representation of the intermediate process, for example the testing and transport of the component. It can also be connected with the control system of the cutting robot, hence tool position data can be generated out of the process model. A holistic tracking of the component history, the testing and transport process up to the reinstallation in a new building is feasible.

**Keywords:** Secondary Building Parts · Semantic Web · Circularity · Process Model

## 1 Introduction

Today, concrete is the most widely used building material in the world. Besides water, sand, rocks and additives, cement is one of the main components of concrete. Every year, four gigatons of cement are produced [1], releasing 8% of the global CO<sup>2</sup> [2]. With the

constantly growing demand, the need for raw materials is also increasing. In addition to extraction, the disposal of concrete also presents our society with new challenges: The dumping of concrete in repositories endangers ecosystems and biodiversity [3].

Current research has been concerned with the non-destructive recovery of building components from demolished buildings as a source for new building parts [4].

By precisely cutting out concrete parts from the buildings to be demolished, new building parts can be produced, which can then be used in new buildings.

For reuse, however, the extracted components must be subjected to intensive special testing [3]. One of the reasons for this is that today's planning models do not allow a connection between demolished and newly constructed buildings, as the current IFC model do only allow one ifcSite [5]. Since the data cannot be transferred to the new model, component information such as construction, reinforcement and installation location of the original component are lost. The aim of the paper is to address this problem by means of a semantic process model. This not only enables the transfer of the original component information into the new component, but also the consistent capturing of the cutting, the inspection and the assembly process.

## 2 Background and Related Works

Currently, the time-consuming and safe extraction process of concrete components for reuse is a major challenge, here the *Robot-assisted deconstruction for reuse using the example of the concrete wall* (ROBETON) project attempts to accelerate the process by a (semi-) automated cutting process by means of a construction robot with a mounted concrete saw [4]. The approach to a semantic process model to enable a new flow of information for the re-use of building materials beyond BIM is based on the development of the ontology.

### 2.1 Robotic Deconstruction Process

The ROBETON research project utilizes the knowledge acquired from a demolition machine, which has been established for over four decades to develop an intelligent robot via digital enhancements to its system control. Digital models of the construction planning are connected to the robot control via a newly developed user interface. Additionally, the (semi-) automated construction robot is supported by a mobile robot for environment perception and component detection. The collected data is used for collision-free planning and execution of the controlled demolition and directly transmitted to the robot control for data synchronization with the planning model.

To execute a planned movement in a controlled manner, a complex coordination of several hydraulic axes is required. The individual axis movements are detected by sensors, and the resulting tool movements for a wall saw are predictively planned before actual execution and adapted to the user requirements and actual construction site environment. The (semi-) automated construction robot is able to precisely, automatically, and minimally invasively cut out the components. The cut-out components can afterwards be reused for further construction and renovation measures [4]. Figure 1 shows the a sketch to demonstrate the cutting process in buildings and the real deconstruction machine with the saw.

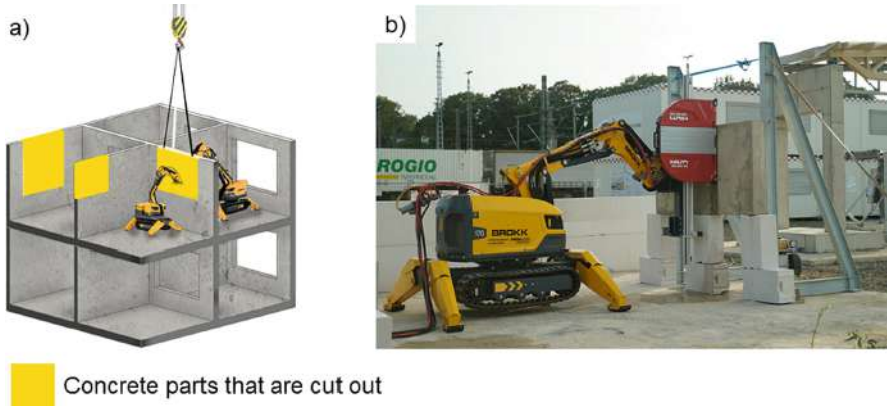

**Fig. 1.** a) sketch to demonstrate cutting process in buildings, b) real set up of deconstruction machine and saw

## 2.2 Ontologies in Construction

Ontologies have emerged as a potential solution to address the problem of semantic interoperability [6–9]. An ontology is a formal specification of concepts in a particular domain, involving a logical theory and reasoning capabilities to deduce new knowledge [10]. They provide explicit data semantics, enabling semantic interoperability by representing entities, concepts, and their relationships in a clear and unambiguous manner [11]. Several ontologies have been developed for the construction domain, with approaches including the translation of existing models [12, 13] or the development of new mapping techniques[14].

For instance, the Internet of Construction (IoC) ontology connects different sub-domains of construction, including steel construction [14, 15]. There are several approaches to enable a digital information flow throughout the construction lifecycle. The Digital Construction Ontologies (DiCon) consist of six modules for specifying construction domain knowledge. The purpose of the ontology is to address the semantic level of this challenge, by providing essential concepts, terms and properties for construction and renovation projects, representing the evolution of information about a building over successive building lifecycle stages. In addition, the ontologies define the necessary relationships between building elements, construction details, materials, and their properties. It is paving the way to ultimate the integration of information from different decentralized sources over the construction lifecycle [14].

Lee et al. developed an ontology model to assist information handling for prefabrication and on-site assembly processes in construction [16].

The shared ontology for Logistics Information Management in the Construction Industry by Zheng et al. is a presentation of a domain-level ontology as a common information reference for standardizing and integrating construction logistics information. It provides information interoperability between logistics management and construction workflow management and improves the efficiency and transparency of logistics

information management. As such, it links construction material with locations, statuses, users and equipment and is evaluated using actual schedule and delivery data of a construction project [17].

The Building Product Ontology (BPO) defines concept to describe building products in a schematic way. It provides methods to define assembly structures and component interconnections and attach properties to any component [18]. Janakiram et al. are concentrating on an efficient representation of various building lifecycle stages in their ontology approach for building lifecycle Stages (BLS). Additionally, it shows stages and sub-stages in the lifecycle of built assets [19]. Thus, focusing on non-geometric descriptions allows manufacturers to benefit from Semantic Web methods without restricting the modelling process of their products [20].

The ifcOWL ontology is built around ifc:root, which contains attributes that enable its association with construction resources, subtasks, and components. The Construction Tasks Ontology (CTO) defines tasks related to construction ventures, including installation, removal, modification, inspection, and repair [12].

The ifcOWL-DfMa ontology is an expansion of the ifcOWL ontology and strives to interpret the lexicon of offsite construction domain in a machine-readable manner, as per reference [21].

Looking at the use of ontologies in construction so far, they can allow linkage of heterogeneous and unstructured data, including various sources of information like BIM or scheduling data. Furthermore, it is advised to have the ontology focus on a specific use-case or problem statement defined as the scope of the ontology. However, previous works have primarily focused on describing general construction processes and do not focus on enabling an information flow for the reuse of concrete components. Therefore, the following methodology focuses on developing a semantic process model for linking the information of concrete components along the entire process chain.

### 3 Methodology

In the following, the developed process from extraction to installation of the extracted components is described. This description serves as a basis for the further development for the description of the reuse process in the semantic process model. The process is adapted to the German standards for the reuse of concrete components.

1. **Preplanning:** The first step is to capture the existing data and identify the corresponding component. For this, the following required information from the new building must be available: Component size, concrete composition, position, number and type of reinforcement.
2. **Extraction of the concrete:** In the next step, the components are cut out from the wall and transported to the site storage or truck. For this process, the information about position, component and dimension are needed for the path planning of the (semi-) automated robot. In addition, the wall thickness must be known for the adjustment of the saw. After separating the component from the wall, the position of the component must be recorded for smooth removal.
3. **Testing process of the components:** Since each component requires a special release for further use, the component must be subjected to a special inspection. Post-treatment might also be required to ensure durability of the component.

4. **Assembly process:** It might be the case that some sub-components will be joined and assembled to one new component.
5. **Installation in the new building:** In the last process step, the components are installed in the new building. For this purpose, the position of the components in the new building must be known.

### 3.1 Scope and Competency Questions

The primary approach employed for creating the ontology is detailed in Noy and McGuinness' "Ontology Development 101: A Guide to Creating Your First Ontology" [22]. Using the selected guide, the initial step in the iterative process is to establish the focus and extent of the ontology. This is accomplished by answering three questions concerning the scope (SCQ).

*SCQ1 What domain should the ontology cover?*

The domain of deconstruction processes for reuse of concrete elements.

*SCQ2 What is the purpose of the ontology?*

The purpose of the ontology is to link building component information throughout the entire deconstruction process chain. This model not only connects information from the existing and new buildings but also facilitates the representation of intermediary processes, such as component testing and transportation. With this holistic approach, it becomes possible to track the component's history and the testing and transport process until its reinstallation in a new building.

*SQ3 What kind of questions should the ontology be able to answer?*

The ontology should describe the link between the element information from the original building, the intermediate processes for extracting and validating the element for reuse and the new building, where it will be reinstalled. This means that it should answer questions about the properties of the element and should provide information about the cutting process. At the same time questions about the transport and inspection process as well as the properties of the new building should be answered. The resulting dataset should be able to allow an ongoing information flow along the entire process chain.

Based on the specification of the scope, a set of competency questions (CQ) was developed, referring to the *ROBETON* project and previous research results in the field of Linked Data. They can be found in Table 1. The nature of these competency questions is technical and functional, outlining the precise queries that the ontology should be capable of addressing once it is established. The following list is a first summary of potential questions which cover different information areas. For example, details about the wall properties from the existing building as well as the requirements from the new building need to be accessible to determine the possible reuse applications. Other information are necessary to enable the deconstruction process itself, e.g. the location of the wall in the building need to be known to position the (semi-) automated construction robot. Furthermore, information about the process itself can be stored for quality control and documentation. So far, the component certification for further use is still challenging. Therefore, the ontology also need to include information to provide the basis for the approval process. During the implementation of the ontology it will be evaluated which questions are missing and need to be added to fully cover the process.

**Table 1.** Competency Questions

Type	Nr.	Questions
Wall properties	CQ1	What is the concrete composition of the existing building?
	CQ2	What is the reinforcement of the wall of the existing building?
	CQ3	What are the concrete and reinforcement requirements of the new building?
Wall location	CQ4	What is the location of the wall which is going to be cut?
Cutting machine	CQ5	Where are the cutting positions on the wall for the component?
	CQ6	What machine and tool will be used to cut the component?
	CQ7	Where are the locations of the machine on site to execute the cutting process?
	CQ8	What is the maximal process force for the machine?
	CQ9	What is the maximal force the machine is able to cover?
Process information	CQ10	How long does the cutting process take?
	CQ11	How much energy was consumed?
Inspection process	CQ12	How does the cutting surface of the component look like?
	CQ13	Is it required to do a post-treatment?
	CQ14	What component certificate is required for the further usage?
	CQ15	What is required for the component certification?
Transport	CQ16	Is the truck able to transport the element?
	CQ17	On which construction site will the component be reinstalled?
	CQ18	When does the component need to be at the new site?
Assembly	CQ19	Which components will be joined together?
	CQ20	What joining method will be used?

### 3.2 Reuse of Existing Concepts

The principle of Linked Data emphasizes the reuse of pre-existing ontologies. However, our investigation into the current status of ontologies in the domain deconstruction has revealed a lack of adequate approaches. None of the existing solutions can fully address the competency questions, especially in the context of (semi)-automatic deconstruction and reusability of elements. Nevertheless, there are mature ontologies available for concepts related to building elements, element metadata and construction processes, which we believe can be applied to this model. Our aim is to enhance interoperability by incorporating these ontologies. A summary of the ontologies that we will use or link is provided in Table 2.

Whereas the first iteration of the ontology focuses mainly on a broader view of the processes and their relations further developments increased depth. For example, during the set-up of the competency questions and the analysis of the process chain it became clear that components size and weight are limiting factors for the transport. Additional

**Table 2.** Overview of the connected ontologies

Namespaces	Main classes/focus and purpose of the ontology	Reference
bot	<i>bot:Zone</i> , <i>bot:Element</i> , <i>bot:Interface</i> Ontology describing the core topological concepts of a building and the relationships between the concepts. One of the central ontologies introduced within the Linked Building Data (LBD) group	[23]
ifc	<i>Ifc:Root</i> Web Ontology Language (OWL) representation of the Industry Foundation Classes (IFC) schema	[24]
ioc	<i>ioc:process</i> Ontology developed within IoC to describe processes and process metadata	In print (not published yet)
opm	<i>opm:PropertyState</i> An ontology for describing properties that change over time	[25]
schema	<i>schema:Thing</i> Collaborative project to develop schemas for structuring data	[26]

requirements for the cutting process and the resulting joining of multiple elements are added to the ontology. Thus, the top-down approach for ontology development, starting with the definition of the most general concepts and refining those afterwards, was used according to Noy and McGuinness.

## 4 Outlook

This work represents the first conceptual approach for setting up a semantic process model to extend the Building Information Model (BIM) for connecting the information from the different buildings and intermediate inspection processes to enable the approval of the components. Previous studies have predominantly concentrated on outlining broad construction procedures, neglecting to emphasize the establishment of an information pathway to facilitate the reuse of concrete components. As a result, the proposed approach centers on the creation of a semantic process model that connects the information pertaining to concrete components throughout the entirety of the process sequence. Currently, concrete holds the distinction of being the most extensively utilized construction material worldwide. As the demand for concrete continues to escalate, so does the requirement for raw materials. The proposed approach facilitates the establishment of an information base that promotes the reuse of existing concrete components as a secondary resource for future construction endeavors.

In view of the increasing resource shortages [1], this approach to the still young field of concrete reuse offers the possibility of a process standardization. In this way, the individual solutions [1, 3, 4, 30] can be placed in a common context with the aim

of: 1) Moving away from a special solution to a broad application 2) Developing new application tools for precise and simplified planning of the reuse processes 3) Developing appropriate tools for extracting the components 4) Standardized connection for assembling the components 5) Cost-effective testing processes for rapid evaluation of the component condition. In future works, the semantic web model will be set up to be able to answer the competency questions raised in this paper.

Subsequent studies must assess the different existing ontologies more extensively to streamline and enhance them to the semantic process model, while analyzing which classes and properties are not yet defined. Additionally, it ought to address the constraints and preconditions of this research, including the essential digital data and modeling proficiency or ways to overcome current drawbacks of utilizing the IFC data model, such as version conflicts or data loss.

#### 4.1 Robotic Implementation

In the following project phase the technical implementation of the robot-assisted deconstruction process of concrete elements and the semantic web approach will be linked. The objective of robotic implementation use case is to connect the distinct process stages (Methodology) with the process model, as only by documenting each step a precise evaluation of the component's quality can be accomplished. The development of the semantic process model creates the basis for this. An instance of a specific process will be demonstrated, elucidating how the position of the component can be transmitted to the robot control of the disassembly robot [27] in ROS [28]. This query consists of three sub-actions.

- 1) Selection of the desired component. This can be done e.g. via a visual interface or directly via an Application Programming Interface (API).
- 2) Once the component has been selected, the robot's target positions must be queried. These are the positions where the robot positions the concrete saw to cut the components [4], for each component, positions have been defined adapted to the process requirements (saw, robot, cutting length). The query can be automated via an API that is directly connected to the database. In addition to the positions, the cutting sequence must also be queried, which is necessary for a successful process to hinder the jamming of the saw blade.
- 3) Subsequently, the data is translated into a `geometry_msgs/PoseStamped` message [29] in ROS, this can be passed to the robot as a target position. Such a `PoseStamped` consists of a position  $[X, Y, Z]$  in space and the orientation in quaternion format  $[x, y, z, W]$ . In addition, each pose is provided with a timestamp that is generated at the time of the query. The positions are passed to the robot controller according to their specified order in a `geometry_msgs/PoseArray` [30].

**Acknowledgement.** The ROBETON research project is funded by the German Federal Institute for Research on Building, Urban Affairs and Spatial Development (BBSR) on behalf of the German Federal Ministry of Housing, Urban Development and Building (BMWSB) with funds from the "Zukunft Bau Forschungsförderung".

Furthermore, the development of the paper content was supported by Timur Kuzu.



## References

1. Devènes, J., Brütting, J., Küpfer, C., et al.: Re: crete – reuse of concrete blocks from cast-in-place building to arch footbridge. *Structures* **43**, 1854–1867 (2022). <https://doi.org/10.1016/j.istruc.2022.07.012>
2. Beton in Zahlen (2021). <https://www.bund-berlin.de/service/meldungen/detail/news/beton-in-zahlen/>
3. Küpfer, C., Bastien-Masse, M., Fivet, C.: Reuse of concrete components in new construction projects: critical review of 77 circular precedents. *J. Clean. Prod.* **383**, 135235 (2023). <https://doi.org/10.1016/j.jclepro.2022.135235>
4. Lee, H.J., Heuer, C., Brell-Cokcan, S.: Concept of a robot assisted on-site deconstruction approach for reusing concrete walls. In: Linner, T., García de Soto, B., Hu, R., et al. (eds.) *Proceedings of the 39th International Symposium on Automation and Robotics in Construction*. International Association for Automation and Robotics in Construction (IAARC) (2022)
5. buildingSMART Technical (2023) ifcSite. <https://standards.buildingsmart.org/IFC/RELEASE/IFC4/ADD1/HTML/schema/ifcproductextension/lexical/ifcsite.htm>. Accessed 29 Mar 2023
6. Sabou, M., Biffi, S., Einfalt, A., et al.: Semantics for cyber-physical systems: a cross-domain perspective. *Semant. Web* **11**, 115–124 (2020). <https://doi.org/10.3233/SW-190381>
7. Wong, A., Ray, P., Parameswaran, N., et al.: Ontology mapping for the interoperability problem in network management. *IEEE J. Sel. Areas Commun.* **23**, 2058–2068 (2005). <https://doi.org/10.1109/JSAC.2005.854130>
8. Gyrard, A., Zimmermann, A., Sheth, A.: Building IoT based applications for smart cities: how can ontology catalogs help? *IEEE Internet Things J.* **5**, 3978–3990 (2018). <https://doi.org/10.1109/jiot.2018.2854278>
9. Cao, Q., Giustozzi, F., Zanni-Merk, C., et al.: Smart condition monitoring for industry 4.0 manufacturing processes: an ontology-based approach. *Cybern. Syst.* **50**, 82–96 (2019). <https://doi.org/10.1080/01969722.2019.1565118>
10. Gruber, T.R.: A translation approach to portable ontology specifications. *Knowl. Acquis.* **5**, 199–220 (1993). <https://doi.org/10.1006/knac.1993.1008>
11. Patil, L., Dutta, D., Sriram, R.: Ontology-based exchange of product data semantics. *IEEE Trans. Automat. Sci. Eng.* **2**, 213–225 (2005). <https://doi.org/10.1109/TASE.2005.849087>
12. Bonduel, M.: A Framework for a Linked Data-based Heritage BIM (2021)
13. buildingSMART Technical (2023) ifcOWL - buildingSMART Technical. <https://technical.buildingsmart.org/standards/ifc/ifc-formats/ifcowl>. Accessed 28 Feb 2023
14. Zheng, Y., Törmä, S., Seppänen, O.: A shared ontology suite for digital construction workflow. *Autom. Constr.* **132**, 103930 (2021). <https://doi.org/10.1016/j.autcon.2021.103930>
15. Kirner, L., Lublasser, E., Brell-Cokcan, S.: Internet of construction: research methods for practical relevance in construction. *Technol. Archit. + Design* **5**, 146–152 (2021). <https://doi.org/10.1080/24751448.2021.1967053>
16. Lee, S., Isaac, S., Bock, T.: An ontology for process information modeling (2015)
17. Zheng, Y., Tetik, M., Törmä, S., et al.: A shared ontology for logistics information management in the construction industry. In: Osumi, H. (ed.) *Proceedings of the 37th International Symposium on Automation and Robotics in Construction (ISARC)*. International Association for Automation and Robotics in Construction (IAARC) (2020)
18. Wagner, A., Moeller, L.K., Leifgen, C., Eller, C.: BPO: building product ontology (2019). <https://www.projekt-scope.de/ontologies/bpo/>
19. Karlapudi, J., Valluru, P., Menzel, K.: Ontology approach for building lifecycle data management (2021)

20. Wagner, A., Rüttel, U. (eds.): BPO: The Building Product Ontology for Assembled Products. Proceedings of the 7th Linked Data in Architecture and Construction Workshop (2019)
21. Kalemi, E.V., Cheung, F., Tawil, A.-R., Patlakas, P., Alyania, K.: ifcOWL-DfMA a new ontology for the offsite construction domain. In: Proceedings of the 8th Linked Data in Architecture and Construction Workshop (2020)
22. Noy, N.: Ontology Development 101: A Guide to Creating Your First Ontology (2001)
23. BOT: the Building Topology Ontology of the W3C Linked Building Data Group swj2224
24. Beetz, J., van Leeuwen, J., de Vries, B.: IfcOWL: a case of transforming EXPRESS schemas into ontologies. *AIEDAM* **23**, 89–101 (2009). <https://doi.org/10.1017/S0890060409000122>
25. Rasmussen, M.H., Lefrançois, M., Bonduel, M., et al.: OPM: an ontology for describing properties that evolve over time (2018)
26. Schema.org - Schema.org (2022). <https://schema.org/>. Accessed 28 Sept 2022
27. Lee, H.J., Brell-Cokcan, S.: Cartesian coordinate control for teleoperated construction machines. *Constr. Robot.* **5**, 1–11 (2021). <https://doi.org/10.1007/s41693-021-00055-y>
28. ROS - Robot Operating System. <https://www.ros.org/>. Accessed 29 Mar 2023
29. geometry\_msgs/PoseStamped Message (2022). [http://docs.ros.org/en/melodic/api/geometry\\_msgs/html/msg/PoseStamped.html](http://docs.ros.org/en/melodic/api/geometry_msgs/html/msg/PoseStamped.html)
30. geometry\_msgs/PoseArray. [http://docs.ros.org/en/noetic/api/geometry\\_msgs/html/msg/PoseArray.html](http://docs.ros.org/en/noetic/api/geometry_msgs/html/msg/PoseArray.html)



# Applicability of a Serious Game Framework for Construction Logistics

Gábor Bohács<sup>(✉)</sup>  and Bálint Bertalan 

Budapest University of Technology and Economics, Műegyetem Rakpart 3, Budapest 1111,  
Hungary  
gabor.bohacs@logisztika.bme.hu

**Abstract.** Intelligence and complexity are increasingly demanded requirements during decision-making. In our former research a software framework has been developed, which enables implementation of process planning in a serious game environment. This method has an advantage in terms of increasing complexity and knowledge retention. Current paper first surveys most important features of serious gaming and points out a lack of the applications directly in planning. In the further part basics of our serious game concept is presented. The method's applicability for construction logistic planning processes is presented via an example. This relates to a complex process of concrete construction, involving the sites, the concrete batching plant and the raw material supply.

**Keywords:** serious games · construction logistics · process planning

## 1 Introduction

With the increase in the complexity of the industrial processes decision-making should also keep up with it. Besides, processing timeframe of the high amount of information, is decreasing. Agility is also increasingly demanded caused by the rapidly changing global economic, environmental background, and ever-increasing market competition. Exceptional conditions are emerging more frequently, Covid pandemic, chip shortage, lack of workforce and supply chain interruptions are only some of the problems which may require quick process replanning.

But currently there are a lot of possibilities as well. Use of the Internet is a widespread daily practice, and increased connectedness among humans, machines and information systems is also established using the principle of Industry 4.0 [1]. Additionally, application possibility of artificial intelligence is exponentially spreading.

In the world of challenges and possibilities, appropriate participation of humans in the processes, particularly in the decision-making is essential. Keeping the human in the loop of process planning and control is inevitable to understand and improve systems using artificial intelligence which also trains the humans capability.

Computer-based serious games are particularly useful in this aspect, because these are capable of integrate human intelligence with machine algorithms. Our paper first surveys

background of serious games. Following, we present a novel serious-game software framework and validate it via an example.

Current research is part of our project INEXT, which is supported by the National Research, Development and Innovation Fund of Hungary under grant no. ED\_18–22018-0006.

## 2 Literature Background

Serious games are interpreted in the scientific community in various ways. A comprehensive survey can be found in [2]. A common opinion is that serious games are the ones combining the entertaining way with the practical content. In other words, serious games are “games that do not have entertainment, enjoyment, or fun as their primary purpose” [3]. This is however sometimes hard to decide if a game is serious or not. Therefore, the context of playing is decisive. If it is related to work or educational purpose, a game is classified as serious. But some point out that there is also a great hype behind it, and they have the opinion that it is only a marketing technique [4]. Serious games are generally classified using the G/P/S model [5]. Here “G” stands for “Gameplay” which can be two kinds. “Game-based” games have well defined goals to achieve, so in each game a winning or losing situation can be evaluated. “Play-based” games don’t have stated goals, the player can propose its own ones. The later one can be used for studying a situation or a system. “P” means “Purpose” in the model, which can be message-broadcasting, training or data exchange. The last classification criteria stands for “Scope”, which describes the group of possible users. This can be for example healthcare, corporate, education, politics, science.

Our intention is to create a platform for the support of planning processes in various industrial areas. Using the above classification model, it is a play-based / data exchange / industry type game.

One possible application area is planning of construction logistics processes. These combine handling of several problem areas (see [6]). Synchronization of on-site and supply logistics has an overall importance. During this, establishment of the supply chains and stocks are necessary, together with the provision of the handling equipment. of the material. Application of diverse handling technologies like cranes, mobile loaders, baggers require proper allocation of the workforce in order to achieve schedule adherence. Construction processes are mostly implemented in large scale and/or complex environment, therefore special infrastructural elements, and layout specifics play an important role. To successfully implement material flows and services, information system needs to be established as well. The described complexity can only be realized by the collaboration of various experts. In order to fine tune the processes in advance, simulation models and serious games can be applied.

Gamification in construction logistics has already implementations. In [7] a construction logistics focused game was proposed, which serves educational purposes. This is however different from our approach, as it is implemented using physical tools rather than software, and it requires competition among the players. As we intend to use our results in process planning, we prefer collaborative characteristics. Through the interaction of various experts during the gameplay, optimized process results can be achieved.

Use of simulation modelling in construction logistics is also researched. Authors in [8] analyses the operations of an on-site batch plant and the concrete supply process using a simulation-based model. The objective of the model's application is the determination of the concrete truck fleet size that fits best the actual tasks.

In latest research, serious games are expanding from the original areas of training and education. In paper [9] a serious game to compare the manual performance of human decision and the use of algorithms is presented. The game also allows humans to create their own automated planning rules, which can also be compared with the implemented algorithms.

In construction processes collaborative planning is an increasing issue. In [10] the author presents a collaborative production planning environment with BIM system. Here live and concurrent collaboration between the participants is proposed. The proposed serious game is different, as it gives priority over multilateral discussions to a more controlled iteration process, where each player has equal priority and necessary time to reach the decisions. We would like to emphasize that neither collaboration planning nor serious game approach has priority, these apply simply different approaches.

Thus, we could not find any references in which serious game is used directly for logistics planning rather than indirectly.

### 3 Description of the Elaborated Framework

Computer-based planning and scheduling of logistics processes is generally done in two main steps. First process information from various experts and databases are collected, and afterwards, computer planning tools, mainly simulation software are applied in order to predict key indicators. This information is then feedback to the experts for further iterations if necessary. During this classical approach, the experts are not directly observing the evolving process, therefore important details can be missed. In serious games, the participants remain attendant during the whole process. This would however require full time attendance from the experts therefore a reasonable new approach is needed.

In our research, a concept is elaborated in which advantages of the serious games are combined with the benefits of software tools' application and artificial intelligence. It is actually a special serious game, in which some players are substituted by AI or reach their decisions using software tool. As the concept's intended main application is logistics planning, a flowchart structure can be drawn, which consists of the planning steps and aspects. Figure 1 depicts an example for this. Here the logistic planning tasks are ordered in a linear structure. Each step obtains input from the previous step and gives output for the next one. In the planning steps 1, 2 and 3 output is generated using only expert knowledge. Step 3 is completely automated, using a standalone interface software which is able to communicate with the serious game, and runs AI algorithms on demand. This can be useful if data is available which can be learned by e.g. a neural network. As an example for that, assume, that we have recorded data on the loading times of trucks with different unit load amount and different number of forklifts. By learning this data, the neural network can predict future scenarios. In step 4 a human participant generates the output, using a software, e.g. computer simulation.

The actual planning task is defined by a flowchart. Elements of this are simply activities by the players. We decided for this simple structure over application of process description languages such as UML, EPC and BPMN, because these already have an extensive ruleset, which would limit the flexibility required in our serious game. During the research a software framework has been developed which is capable of flowchart creation and editing.

The serious game has been implemented via WebAssembly and Blazor and containerized by Docker. The first two allowed that both the frontend and the backend could be implemented in C# with a common codebase for the parts that could be shared between the two components, and the last one allowed easier storage and hosting. In the platform the user can register to the serious game with an email, username and password triplet and then use either the email or the username with the password to log in.

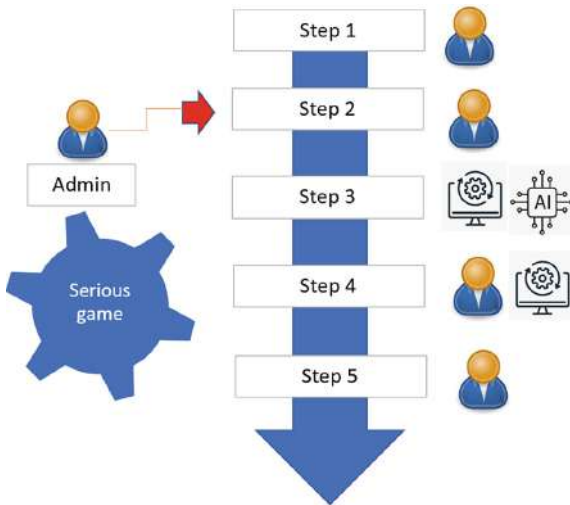

**Fig. 1.** Depiction of the proposed serious game's basics

After that, the user receives a JSON token which can be used in every message in order to authenticate the user and allow access to the platform.

Flowchart creation is done by the game administrator, who defines for each step following information:

- a name and description of the task,
- participant or software interface assignment for the execution of the actual task,
- input data specification from previous steps,
- output data for next players

Afterwards, connections between consecutive tasks are drawn. After the game has been created in a flowchart form, it is released by the administrator. This serious game doesn't require the participants to be physically in the same place and time. If a certain player has an actual task, because previous players have finished their tasks, a notification has been sent out about the actual required activity. This eliminates common

disadvantage of group meetings and brainstorming, where the involvement of the participants fluctuates according to their expertise. That leads inevitable to utilization gaps and ineffective planning process. A further problem may arise if somebody forgets or miscalculates something. In this case result of the meeting is invalid and can only be corrected via numerous emails or another meeting. In the proposed framework responsibility of the participants can be established, as the players' outputs are recorded. If someone gives an unrealistic output, it can turn out in later phases, and can be sent back to the process step where to problem may have occurred.

So, the participants work on the planning process steps only when their task is actual. The processing of the task is carried out in the serious game framework: the player first reads the obtained input, makes the processing using necessary calculations and software, finally generates an output in the serious game framework. The player can add keywords and comments on the specifics of the decision. That not only helps the other players understanding why the output was made that way, but makes up a good basis to reuse the information and learn from it.

Planning tasks are normally iterative. The conceived serious game-based framework is also capable of handling these situations. The players are allowed to send back the received information to the previous phase for amendment and resend. The cause for this are situations in which the actual task cannot be solved, because of for example capacity limits. The game ends if all the tasks are processed successfully.

## 4 Application of the Framework via an Example

In order to give more insight on the functioning of the concept an example from construction logistics is presented. Main goal is to play through a concrete production and installation process, starting from the supply of ready-mixed concrete batching plants (RMC) to the concreting a the sites. This involves technological and logistic transport tasks as well. The overall process structure is presented in Fig. 2., depicting the already defined tasks and their relation in the serious game model.

Next details of the structure will be described. Playing this serious game require following player roles, and related tasks:

There is a "Network coordinator", who is only responsible in task "Order assignment" during which he aggregates the site demands and divides them to both RMC plants. This role can be implemented using a machine algorithm as well, if the only requirement is to secure smooth, evenly distributed workload, or match RMC plants and closest construction sites.

The "Weather assistant" interacts into the game at two points. First, at the start of process, during the "Weather forecast" task a time series of data is supplied for the "Site managers". These include for each day of the planning period, degree of suitability for concreting from the weather aspect. Second, he will act in the "Weather impact calculation" task, during which he possibly reduces the degree of implemented concreting at the sites, which may be caused by weather.

The "Constructional equipment manager" has also a reducing effect. He acts solely in the "Constructional equipment impact" task. Depending on the concreting intensity, he can make reductions on the implemented concreting, because of expected maintenance

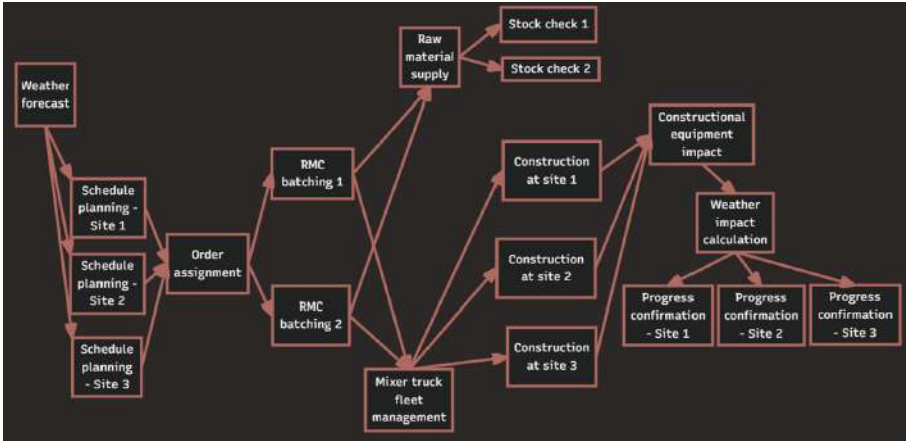

Fig. 2. The example serious game model.

and malfunctions. This task is also possible to be processed by AI, if there are relevant data from previous construction sites.

The “Mixer truck fleet manager” acts only once during the process (“Mixer truck fleet management”). His task is organization of the concrete transports among the RMC plants and construction sites.

The “Raw material supplier” obtains material orders from the RMC plants for cement and for the various aggregates, in the “Raw material supply” process. Output of this task is a list of confirmed delivery dates.

There are also three “Site manager” roles in the game. They process several tasks. First, they set-up an appropriate schedule (“Schedule planning ...”) for the sites using the weather forecast, and additional information on the construction project requirements. They also manage processes at the sites (“Construction at site...”), where they obtain deliveries and outputs time series of the concreting times. This is further checked from weather and equipment availability aspects by other players. Finally during “Progress confirmation ...” tasks they check whether the reduced amount is acceptable or not.

Two “RMC batching plant manager” roles are also included. They process “RMC batching...” tasks, where the outputs are the necessary raw material supplies and concrete transport demands. Prediction of the RMC plant processes can be largely helped, if a process simulation model exists for the plant. This role has also a “Stock check ...” process, which serves as a confirmation of raw material supplies.

Lack of a global objective function for the whole system is an important feature. All the players try to achieve their own optimal operation. If these are contradicting, certain process inputs can be rejected by the consecutive processes. If there is still no solution after several iterations the gameplay fails, and the contradictions must be handled by higher level managers outside the game. The serious game however supplies also in these cases valuable information.



## 5 Summary and Further Research

The presented serious game-based framework has been developed for intralogistics purposes. Later we realized that it can be used in further areas as well.

Later we will develop this framework further. In that phase using AI algorithms we will be capable of analyze the previously played serious games, and search for patterns, which can be reused. Besides, we will use it for bidirectional learning between humans and machines. Machine intelligence will be able to understand the information but by humans during gameplay. We will also focus on the application of explainable AIs, which makes possible for humans to understand how the AI component solved a certain task. As a result, this collaborating, human-machine systems will enable increased capability of understanding and handling more complex systems.

## References

1. Monostori, L., et al.: Cyber-physical systems in manufacturing. *CIRP Ann.* **65**(2), 621–641 (2016)
2. Laamarti, F., Eid, M., El Saddik, A.: An overview of serious games. *Int. J. Comput. Games Technol.* **2014**, 1–15 (2014). <https://doi.org/10.1155/2014/358152>
3. Pereira, G., et al.: Serious games for personal and social learning & ethics: status and trends. *Procedia Comput. Sci.* **15**, 53–65 (2012). <https://doi.org/10.1016/j.procs.2012.10.058>
4. Ritterfeld, U., Cody, M., Vorderer, P. (Eds.) *Serious Games* (2009). <https://doi.org/10.4324/9780203891650>
5. Djaouti, D., Alvarez, J., Jessel, J.-P.: Classifying serious games. In: *Handbook of Research on Improving Learning and Motivation through Educational Games*, pp. 118–136 (n.d.). <https://doi.org/10.4018/978-1-60960-495-0.ch006>
6. Fadiya, O., Georgakis, P., Chinyio, E., Nwagboso, C.: Decision-making framework for selecting ICT-based construction logistics systems. *J. Eng. Des. Technol.* **13**(2), 260–281 (2015). <https://doi.org/10.1108/jedt-07-2011-0047>
7. Bergström, K., Billger, M., Fredriksson, A., Janné, M.: The MIMIC construction logistics game: facilitating group discussion and understanding of construction logistics through gameplay. In: *IOP Conference Series: Earth and Environmental Science*, vol. 588(5), p. 052014 (2020). <https://doi.org/10.1088/1755-1315/588/5/052014>
8. Panas, A., Pantouvakis, J.-P.: Simulation-based concrete truck-mixers fleet size determination for on-site batch plant operation. *Procedia. Soc. Behav. Sci.* **74**, 459–467 (2013). <https://doi.org/10.1016/j.sbspro.2013.03.050>
9. Mes, M., van Heeswijk, W.: Comparison of manual and automated decision-making with a logistics serious game. In: Lalla-Ruiz, E., Mes, M., Voß, S. (eds.) *ICCL 2020. LNCS*, vol. 12433, pp. 698–714. Springer, Cham (2020). [https://doi.org/10.1007/978-3-030-59747-4\\_45](https://doi.org/10.1007/978-3-030-59747-4_45)
10. Tallgren, M.V.: Collaborative production planning with BIM - Design, development and evaluation of a Virtual Production Planning system (2021). <https://doi.org/10.13140/RG.2.2.10001.56166>



# Smart Contract-Enabled Construction Claim Management in BIM and CDE-Enhanced Data Environment

Xuling Ye<sup>1</sup>(✉) , Ningshuang Zeng<sup>2</sup> , Yan Liu<sup>3</sup> , and Markus König<sup>1</sup> 

<sup>1</sup> Ruhr-University Bochum, Universitaetsstrasse 150, 44801 Bochum, Germany  
xuling.ye@rub.de

<sup>2</sup> Southeast University, Southeast University Road No. 2, Nanjing 211189, China

<sup>3</sup> Nanjing University, Pingcang Lane No. 5, Nanjing 210000, China

**Abstract.** With the advanced information and communications technologies (ICTs) in the construction claim management, such as ontology, data mining, and building information modeling (BIM), many aspects have been improved, including construction claim early identification, analysis and visualization. However, due to the complex and lengthy nature of construction claim procedure, how to execute and visualize it digitally with data traceability is not yet been studied. Integrating these technologies with blockchain and smart contracts, data integrity and process tracing can be ensured for construction claim management. This study proposes a framework to integrate BIM, blockchain, smart contracts and common data environment (CDE) focusing on construction claim procedure generation, execution and visualization. The framework is developed to help improve the traceability, transparency and automation of the construction claim procedure. A case study is illustrated to demonstrate and evaluate the current implementation of the proposed framework. Several aspects for improvement and future directions are discussed in the end.

**Keywords:** Smart Contracts · Construction Claim Management · BIM · Blockchain · CDE

## 1 Introduction

In the construction logistics field, on-site and off-site disruptions can cause a cascading effect, making it difficult to clarify the responsibility for the loss and manage claims. For example, due to the dependence among construction activities, invisible off-site disruptions of any essential construction task may lead to delays in a construction project. The sum referred to the delay damages can be very large. Meanwhile, such damages are excluded from the insurance policy. The compensation from suppliers frequently cannot cover the loss of the contractor. There are many problems in claim management involving essential project stakeholders, but there are even greater challenges in claims related to construction logistics. Claims can protect legitimate rights and interests of contractors and clients, make up for project losses, and improve the overall benefits of a

project. According to relevant statistics, in the international market, project management can increase the economic benefits of projects by 3% to 5%, while effective claim management can increase project profits by 10% to 20%. In many construction projects, the increased income of the contractor through successful claims reaches more than 15% of the original contract price [1].

Emerging Information and Communication Technologies (ICTs), e.g., Building Information Modeling (BIM), Common Data Environment (CDE), and blockchain, are reshaping the process and system of claims in construction projects. BIM and CDE can provide as-designed and as-built multi-source data with visual models, which contribute to the digitalization of claim processes. Based on the overall interests of both parties to the contract, malicious abuse of claims should be avoided as much as possible. This relies on the authority, fairness and openness of the claim evidence and claim process. However, emerging technologies such as BIM and CDE cannot guarantee this important aspect. In the current ICT-enabled claim processes, the integrity, traceability and credibility of claim evidence data are still key issues. Besides data problems, ensuring the traceability and reliability of collaborative claim processes must also be realized.

The emergence and development of blockchain and smart contracts provide new technical support for solving the problem related to the integrity, traceability and credibility of claim evidence and processes. Blockchain-enabled claim paradigm can consequently transfer trust from people to the digital platform based on the flexibility provided by smart contracts. Therefore, this paper proposed a smart contract-enabled construction claim management platform. Gaps and technical limitations in ICT-enabled construction claim management are first analyzed. Then this paper proposed a three-stage methodology to develop a smart-contract-enabled construction claim management framework, which integrates BIM- and CDE-enhanced data environment. Further, a case study was conducted to prove the concept and help clarify the contribution and practical implications.

## 2 Related Work

### 2.1 ICT-Enabled Construction Claims Management

In the construction claim management, the research about using ICTs has appeared over decades. In 1995, Alkass et al. [2] proposed a computer system for construction delays claim analysis using the isolated delay type (IDT) technique and an expert system (delay advisor) for decision making. As time goes by, more and more ICTs are proposed to be used in this field, such as ontology for automatic generation of construction claim documents [3] and BIM for identifying construction claims [4]. Guévremont and Hammad [5] conducted a review and survey focusing on 4D BIM simulation applications for construction claim delay visualization. An approach was proposed to identify construction by integrating BIM with time and cost as inputs and using rule-based checking [3]. Parchami Jalal et al. [4] presented a BIM-based construction claim management model for early identification and visualization of claims, where claims are identified based on the changes of their corresponding BIM models.

The CDE is defined to store all the data (i.e., geometrical and semantic information as well as the documentation) related to the lifecycle of a construction project [6].

Therefore, the CDE could be used as an off-chain data storage to connect with the Blockchain in the construction sector. Due to its functions of bringing all information together and serving as central data management tool, the CDE is widely recognized as a solution for implementing the BIM method [7]. Meanwhile, Preidel et al. [7] listed several existing approaches which could be a CDE application: BIMserver.org, A360 & Forge, BIMcloud, BIMcollab, bim + and Trimble connect.

Even through ICTs improve the construction claim management, some issues still exist. The trust issue could be the biggest among them. How to establish trust between people and technology, and between people has become an increasingly important issue. As disputes are common in the construction claims, traceability may be needed when executing a claim. Meanwhile, claim procedure is lengthy and complex, which is not yet presented in any existing BIM-enabled project management system. For example, 4D BIM is used for scheduling, but claim procedure cannot be easily presented in such schedule. Finally, construction claim management normally contains several stakeholders, which cannot easily cooperate using BIM. Therefore, further technologies are needed to integrate with BIM to further build trust, provide traceability, present real-time claim execution procedure, and enable user collaboration at the same time.

## 2.2 Blockchain and Smart Contract for Data Integrity and Process Tracing

The term “smart contract” was first proposed in 1994 by Szabo, who defined it as a digital program that executes legal contracts [8]. In late 2013, smart contracts were implemented in the Ethereum blockchain, which are further defined as systems that automatically execute transactions based on pre-defined rules [9]. Since then, smart contracts can be used to design specific logic based on the purpose of applications. Through the design and implementation of domain-specific smart contracts, blockchain applications can store the state of domain-specific data in key-value format. Consequently, they can be used in other areas, for example, manufacturing control, law enforcement, E-Government, and healthcare [10].

Due to the importance of BIM in the construction industry, many researchers discussed the integration of smart contracts with BIM to assist the BIM workflow execution, the BIM change information management, etc. For example, Xue and Lu [11] proposed a BIM change contract, which was a smart contract-like protocol for integrating distributed semantic differential transaction records from different BIM participants to calculate the important semantic changes in BIM and reduce the information redundancy. Gao and Zhong [12] designed a framework focusing on reviewing design drawings using BIM, blockchain and Decentralized Application (DApp) in code compliance checking of building designs during the design and construction process.

With the limited storage of blockchain, many researchers studied the possibilities of combining blockchain with off-chain storages, such as InterPlanetary File System (IPFS), Structured Query Language (SQL) database, and CDE. Tao et al. [13] explored a distributed CDE by combining blockchain with IPFS off-chain storage for secure BIM-based collaborative design. Erri Pradeep et al. [14] designed a prototype integrating blockchain and SQLite to handle information exchange records for construction design process, where the process tracing ability of blockchain and smart contracts is used to record and trace the information exchange during the construction design process.

The researchers [15, 16] proposed to use CDE as an off-chain storage with a proposed framework for payment automation and contract management.

Even though many blockchain and smart contracts applications are studied in the construction sector, they are not yet been explored in the construction claims. Due to their ability for ensuring data integrity (e.g., compliance checking), integrating with BIM and off-chain storages (e.g., CDE), improving process tracing, combining BIM and CDE with blockchain and smart contracts can be a good solution for handling the construction claim management issues mentioned in Sect. 2.1.

### 3 Methodology

The proposed framework with three stages is shown as Fig. 1.

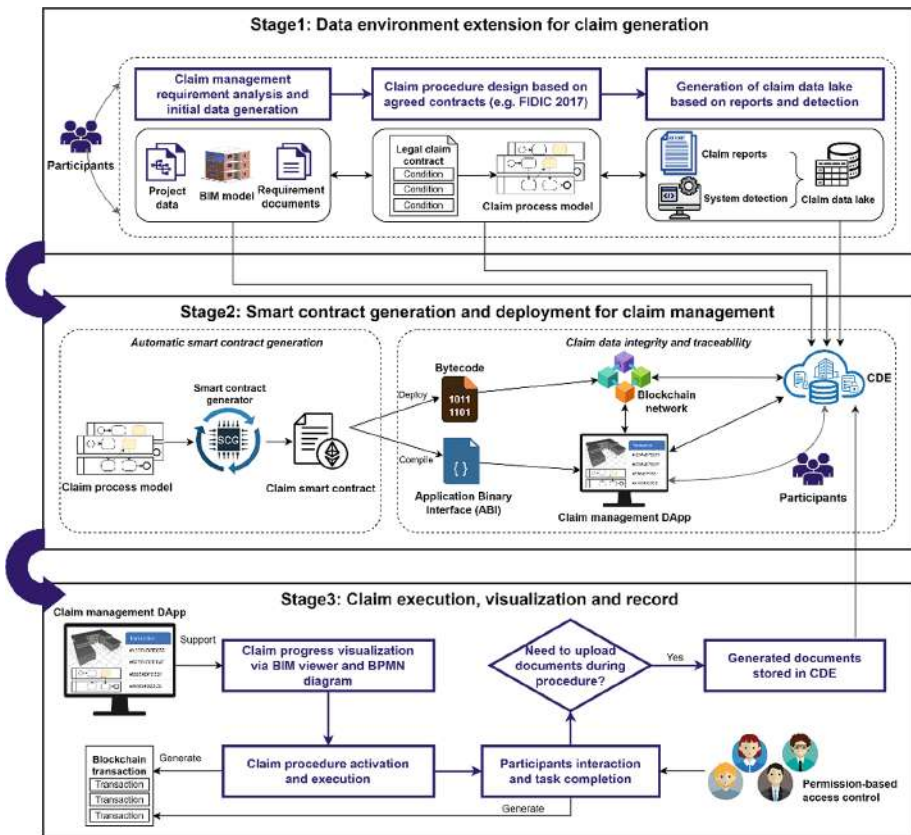

Fig. 1. Overall Framework

The first stage includes three main steps, namely claim requirement analysis and initial data generation, claim procedure design, and claim data lake generation. When a

construction project is started, the corresponding data are initialized by e.g., designing its BIM model and drawing up contracts with claim clauses. Based on these claim-required data, a claim procedure is designed, and its claim process model is generated. After designing such a claim procedure, claim data lake is formed based on claim reports and claim data generated via system detection during the claim procedure. All the data generated in Stage 1 will be stored and operated in the second stage.

A claim process model generated based on FIDIC 2017 construction contract – an international standard form of a construction contract developed by the Federation Internationale des Ingénieurs-Conseils (FIDIC) – is presented in Fig. 2. In this claim process model, three roles are involved, namely the claiming party (i.e., client or contractor), the engineer, and the other party (i.e., contractor or client).

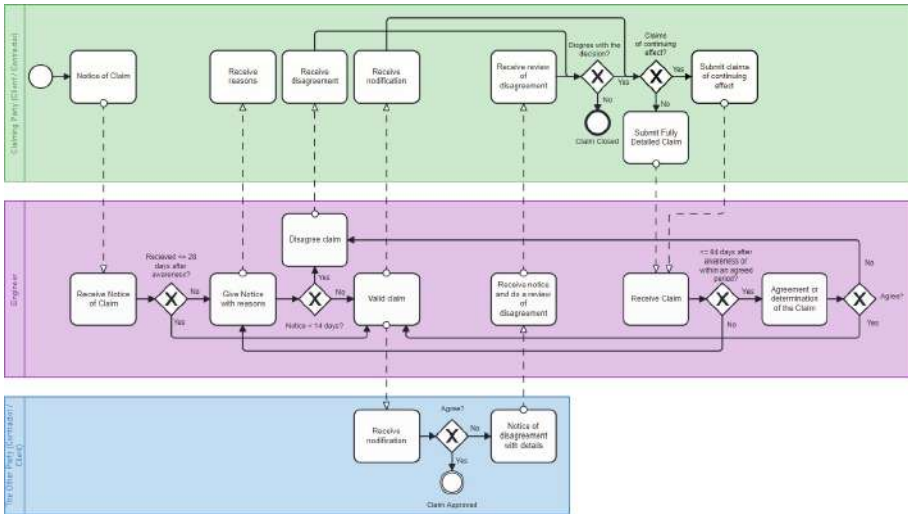

Fig. 2. Claim procedure of FIDIC 2017 construction contract

The second stage focuses on two aspects, which are: Automatic smart contract generation and claim data integrity and traceability. In the first procedure, the claim process model generated from stage 1 is translated into the corresponding claim smart contract via a self-developed smart contract generator [17]. Afterwards, the smart contract is deployed to the blockchain network and the self-developed claim management DApp, which link with CDE for managing claim data generated from stage 1.

In the stage 3, claims are executed, visualized and recorded via the self-developed claim management DApp. In this DApp, a BIM viewer and a BPMN viewer are implemented for visualizing the BIM model and claim process model generated from the stage 1. When a claim is started in the construction project, the claim procedure will be activated and executed in the claim management DApp, with the visualization of real-time progress. When a claim task is activated (e.g., “Notice of Claim” task in Fig. 2), its execution status will be stored as transactions in the blockchain, and this task will be marked with a different color (e.g., green) in the BPMN viewer to indicate that it is

an executing task. All the task completion and participants interaction are recorded as transactions in the blockchain. When uploading documents are required in a task, the documents will be stored in the CDE, and their hash values (as an identifier for each uploaded document) will be recorded in the blockchain.

## 4 Case Study

A construction project is about building a three-inverted-Y-shaped-tower single-cable plane cable-stayed bridge. An N contract section includes the construction of main tower A, south shore side tower B, and the shore C, D, E three piers. The client and the contractor agreed on the N contract section with the start date, 12-month duration, and the completion date of main tower column under tower A to the elevation  $v + 50.00\text{m}$  to ensure continuous construction when the flood season comes. The client should provide the contractor with level points and coordinate information and site delivery, and hand over the construction site to the contractor with connection to the water, electricity, other construction pipelines, and the start date of power supply.

However, due to the client's insufficient preparatory work for construction, the contractor's entry and construction were affected, mainly in the following aspects: 1) The land acquisition and demolition work of the owner has not been completed and the site cannot be handed over on schedule; 2) The engineer's delivery of level points and coordinate information to the contractor was delayed and its data was wrong; 3) The time of power supply is delayed; 4) When the foundation of main tower A was under construction, the contractor found that there was a big difference between the actual geological conditions and the description in the bidding documents.

Due to the combined effect of the above factors, the construction progress of the main tower column under tower A failed to reach the agreed elevation  $v + 50.00\text{m}$  when the flood season came and was forced to stop the work during the flood season, resulting in a delay of 10 months in the construction period of this contract section (Table 1).

**Table 1.** The list of claims

No	Construction process	Planned days	Actual days	Delay days	Delay reasons
1	Delayed start time			8	Insufficient preparatory work by the client
2	Main tower A foundation construction platform	30	41	11	Unfavorable geological conditions, design changes, etc
3	Main tower A main pile foundation construction	59	101	42	1–3 combined effects
4	Shutdown during flood season		214	214	
Sum up				275	



The corresponding claim management DApp developed based on the proposed framework is shown in Fig. 3, which contains smart contract process (shown as BPMN diagram, with an executing task highlighted as green), smart contract functions (each BPMN task links to a smart contract function), BIM viewer, construction claim list (based on Table 1), and blockchain information.

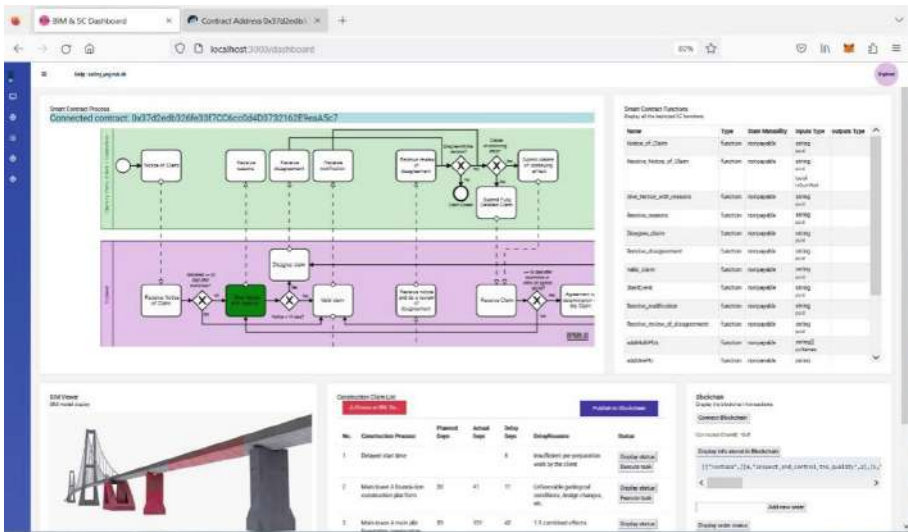

Fig. 3. The developed claim management DApp for the case study

## 5 Conclusion

This paper proposes a framework using BIM, smart contracts, blockchain and CDE to improve traceability, transparency and automation and ensure data integrity and process tracing for construction claim management. This framework contains three stages, namely data environment extension for claim generation, smart contract generation and deployment for claim management, and claim execution, visualization and record, which covers the construction claim lifecycle from claim generation to claim final record. The framework is tested by an implementation of the claim management DApp and a case study of a bridge construction project with construction delay claims.

There can be several interesting future improvement and directions of this study. First, due to the limited length of the paper, many interesting theoretical and technical contents of the claim management DApp implementation are not introduced (e.g., the ability of improving process automation), which will be further illustrated in the future. The case study only considered the construction delay claims, which should be further complicated by adding more claim types (e.g., change order claims). Additionally, in this study, the BIM model is only used to visualize the construction works and connect with construction claims. In the future, scheduling could be added to further visualize



the real-time construction progress of the project, and digital twin could also be added to the proposed framework for early claim identification.

## References

1. El-adaway, I.H., Abotaleb, I.S., Eid, M.S., May, S., Netherton, L., Vest, J.: Contract administration guidelines for public infrastructure projects in the united states and saudi arabia: comparative analysis approach. *J. Constr. Eng. Manage.* **114**, 04018031 (2018)
2. Alkass, S., Mazerolle, M., Tribaldos, E., Harris, F.: Computer aided construction delay analysis and claims preparation. *Constr. Man. Econ.* **13**, 335–352 (1995)
3. Shahhosseini, V., Hajarolasvadi, H.: A conceptual framework for developing a BIM-enabled claim management system. *Int. J. Constr. Manag.* **21**, 208–222 (2018)
4. Parchami Jalal, M., Yavari Roushan, T., Noorzai, E., Alizadeh, M.: A BIM-based construction claim management model for early identification and visualization of claims. *SASBE* **10**, 227–257 (2021)
5. Guévremont, M., Hammad, A.: Review and survey of 4D simulation applications in forensic investigation of delay claims in construction projects. *J. Leg. Aff. Dispute Resolut. Eng. Constr.* **12**, 04520017 (2020)
6. PAS 1192–2:2013: Specification for information management for the capital/delivery phase of construction projects using building information modelling, 1st edn. BSI British Standards, London (PAS 1192–2:2013) (2013)
7. Preidel, C., Borrmann, A., Oberender, C., Tretheway, M.: Seamless integration of common data environment access into bim authoring applications: the BIM integration framework. In: *eWork and eBusiness in Architecture, Engineering and Construction: ECPPM 2016. Proceedings of the ECPPM 2016* (2016)
8. Szabo, N.: Smart contracts. *Virtual Sch.* **35**, 26 (1994)
9. Buterin, V.: A next-generation smart contract and decentralized application platform. White paper 3 (2014)
10. Wang, S., Ouyang, L., Yuan, Y., Ni, X., Han, X., Wang, F.-Y.: Blockchain-enabled smart contracts: architecture, applications, and future trends. *IEEE Trans. Syst. Man Cybern. Syst.* **49**, 2266–2277 (2019)
11. Xue, F., Lu, W.: A semantic differential transaction approach to minimizing information redundancy for BIM and blockchain integration. *Autom. Constr.* **118**, 103270 (2020)
12. Gao, H., Zhong, B.: A blockchain-based framework for supporting BIM-based building code compliance checking workflow. In: *IOP Conference Series: Materials Science and Engineering*, vol. 1218, p. 012016 (2022)
13. Tao, X., Das, M., Liu, Y., Cheng, J.C.: Distributed common data environment using blockchain and interplanetary file system for secure BIM-based collaborative design. *Autom. Constr.* **130**, 103851 (2021)
14. Pradeep, A.S.E., Yiu, T.W., Zou, Y., Amor, R.: Blockchain-aided information exchange records for design liability control and improved security. *Autom. Constr.* **126**, 103667 (2021)
15. Ye, X., Zeng, N., König, M.: Visualization of blockchain-based smart contracts for delivery, acceptance, and payment process using BIM. In: *IOP Conference Series: Earth and Environmental Science* (2022)
16. Ye, X., König, M.: Framework for automated billing in the construction industry using BIM and smart contracts. In: Toledo Santos, E., Scheer, S. (eds.) *ICCCBE 2020. LNCE*, vol. 98, pp. 824–838. Springer, Cham (2021). [https://doi.org/10.1007/978-3-030-51295-8\\_57](https://doi.org/10.1007/978-3-030-51295-8_57)
17. Ye, X., König, M.: From the graphical representation to the smart contract language: a use case in the construction industry. In: *ISARC Proceedings*, pp. 272–279 (2021)



# Automated Productivity Evaluation of Concreting Works: The Example of Concrete Pillar Production

Fabian Pfitzner<sup>1,2</sup>(✉), Jonas Schlenger<sup>1,2</sup>, and André Borrmann<sup>1,2</sup>

<sup>1</sup> Chair of Computational Modeling and Simulation, Technical University of Munich, Munich, Germany

fabian.pfitzner@tum.de

<sup>2</sup> Leonhard Obermeyer Center, TUM Center of Digital Methods for the Built Environment, Munich, Germany

**Abstract.** Site schedules are usually developed by the rule of thumb based on the experience of on-site managers. While this approach can be suitable for smaller job sites, it is challenging to make good decisions for larger projects. Planning errors can result in massive delays and increasing costs. Significant improvements in other industries showed that data-driven productivity analysis of past processes advances the planning and execution of current and future projects. However, in the Architecture, Engineering & Construction (AEC) domain, automated productivity analysis of the construction phase has barely been investigated.

To overcome this deficiency, this paper presents a first approach for multi-level productivity analysis of shell constructions. We discuss several state-of-the-art vision-based technologies that serve as a foundation for large-scale evaluation of the progress on a construction site. A complete pipeline is introduced that uses different types of neural networks to extract productivity information from images at various levels of detail. The proposed workflow is demonstrated for the construction process of cast-in-place concrete pillars, implementing the first two layers. Finally, remaining challenges are discussed.

**Keywords:** construction monitoring · data mining · productivity

## 1 Introduction

For planning of construction projects, it is of utmost importance to make good estimations of how long individual construction processes will take. This highly influences the project end date and also the project cost. So-called expense values are reference values that describe the working hours required to complete a certain task, e.g. build one meter of concrete wall. They can be specific to the construction method used, differentiate between various types of building elements or other criteria and are based on the requirements of the ongoing planning phase

[1]. In current practice, the expense values are often estimated by the project planner or construction manager using experience, tacit knowledge and gut feeling. Some companies perform time measurements of specific processes to obtain reference values. Yet another option is to rely on expense values provided by the literature. These are often calculated based on responses from expert interviews. All these options can be highly influenced by the subjective perception of the construction planner, interviewed expert, or the construction worker who notes down the time he/she spent on a construction task. Furthermore, the expense values are influenced by many different factors, like the construction method used, the specific circumstances of the construction site and project, as well as the company's internal processes [2, 3].

Within the last few years, a lot of progress has been made in the field of automated image analysis. Especially, AI-based approaches have found application in many fields, including the construction industry. Since acquiring regular images from a construction site is very affordable compared to other types of sensor data, they have become popular input data for many different types of automated analysis. AI-based approaches to process images can also provide progress-related information that is essential for automated productivity evaluation. They are characterized by fast execution times, which makes them suitable for application on large data sets [4].

Even though productivity on construction sites is a crucial topic, previous productivity analysis in construction is either based on surveys [2] or conducted in small-scale, well-controlled surroundings over a short period of time [5, 6]. The lack of comprehensive productivity analysis is related to the limited availability of large data sets and computational resources. Both result in uncertainties of the derived statements about productivity in construction and make their validity for a wide range of construction projects questionable. Therefore, a data-driven approach is required to objectively judge productivity. The aim of our work is to enhance the understanding of productivity in the context of the entire construction environment. For this, insights are given into how productivity is calculated according to the construction practice. Furthermore, state-of-the-art vision-based approaches are presented that can serve as a basis for automated productivity analysis. As the main contribution of this paper, we propose a methodology that allows to determine productivity-related values in varying levels of granularity. It is demonstrated with a prototypical implementation on the example of erecting cast-in-place concrete pillars, identifying the individual operational states *not started*, *rebar*, *formwork*, and *finished*. The pipeline is presented together with remaining challenges, especially in regard to fine-grained productivity evaluation.

## 2 Background

### 2.1 Construction Monitoring

A large amount of monitoring solutions are being developed to support construction environments. For this purpose, various sensor technologies such as

laser scanners, cameras, and Bluetooth Low Energy (BLE) tracking systems have been considered [7, 8]. A conventional approach to monitoring construction progress is through image-based methods, which rely on capturing images and processing them to obtain information about the construction site. The information extraction is increasingly performed using machine learning methods [9]. This information is essential to represent the as-performed construction state by a digital twin [10]. Studies that provide insights into the construction phase based on real-world construction sites are scarce. Further research is necessary to develop a comprehensive understanding of the benefits and limitations of using diverse technologies like UAVs and crane cameras for monitoring construction sites and creating an as-performed digital twin [11].

## 2.2 Vision-Based AI Methods in Construction

In recent years, there have been significant improvements in computer vision technology, particularly in image classification [12], object detection [13], and semantic segmentation [14]. These advancements have unveiled potential use cases for computer vision technology in the construction industry. Some potential applications of image-based methods in construction include identifying safety hazards, monitoring construction progress, and conducting quality control checks [9]. With the development of more sophisticated computer vision algorithms, these applications will become more accurate and reliable, leading to safer and more efficient construction environments.

In the context of progress monitoring and productivity analysis, existing vision-based approaches can be classified into two different groups. On the one hand side, some researchers focus on the construction workers or the equipment as main objects of interest. As an example, [5] detect construction workers on images to estimate their productivity. Based on their pose, they distinguish between effective, ineffective, and contributory work. Similarly, [6] track construction workers to identify their actions. Using YOWO (You Only Watch Once), a neural network that simultaneously executes object detection and classification, they detect workers in images and categorize their actions into standing, walking, transporting, drilling, and hammering. Focusing on the concrete bucket as the critical resource for the concreting process, [15] assesses the productivity of concreting works. Depending on the bucket's location, its current status is identified, while its change over time indicates different types of production scenarios. On the other hand, some researchers focus on the building elements that are the primary output of the construction processes to judge progress and productivity. In their literature review, [4] showed that many approaches are based on 3D reconstruction from a set of images, while others directly analyze the 2D images. As an example, [16] monitor the installation process of precast wall elements. They use a combination of several neural networks for objection detection, instance segmentation, and object tracking. With this methodology, they are able to identify when wall elements are moved by the tower crane or installed in their final location.

### 3 Productivity in Construction

To evaluate how well processes are executed, they need to be observed and measured. Only then it is possible to timely detect deviations from the plan and induce change. Many industries determine productivity values of processes to quantify their effectiveness. In the construction industry, different types of productivity-related values are significant as reference values for construction planning. They help to make more accurate estimations of a project's required time and cost. On a generic level, productivity is defined by the ratio of input to the output of an activity, as shown in Eq. (1) [2]. The input can include labor, required construction materials, used equipment, and more. The output often refers to the building elements that are built as the result of the construction process.

$$Productivity = \frac{Output}{Input} \quad (1)$$

It is the objective of construction managers to constantly enhance productivity by increasing production quantities, reducing costs, and improving profit margins. Specifically, the income-to-expense ratio is of high interest to construction managers when it comes to calculating the project costs to be expected, since it determines the construction company's efficiency and profit [2]. Even though productivity values can reflect long-time average values, they can not be assumed as constant during a single construction project. Every project undergoes various changes of productivity over time. During the early phase, the construction workers need to set up and get familiar with the processes of this particular construction site. During this initial adoption phase, productivity will be lower than during the main phase. Towards the end of the project, there is another phase of lowered productivity because of a lower amount of workers on site and the characteristics of the finishing works. Therefore, productivity can be considered as constantly changing [2]. While productivity describes the actual number or volume of building elements per labor unit, the expense value defines the amount of labor required for a certain element. Expense values ( $Exp$ ) have a significant impact on the overall productivity of the project and are therefore included in process productivity estimation [1].

$$Productivity_x = \frac{1}{Exp_x} \quad (2)$$

To estimate expense values, the total amount of working hours ( $H_t$ ) is divided by the amount of produced components. The number of working hours can be further dissected by multiplying the number of workers ( $A_w$ ), the working hours per day ( $H_d$ ), and the duration of the process in days ( $d$ ) [2, 17, 18].

$$Exp_x = \frac{H_t}{V_t} = \frac{A_w \cdot d \cdot H_d}{V_t} \quad (3)$$

Productivity and expense values can be calculated at various granularity levels. On the top-most level, they are determined on the basis of all types of

processes on the construction site. Going more into detail, they are differentiated based on the type of construction work. As an example, productivity could be calculated separately for excavations, masonry, and reinforced concrete elements. These can be further dissected into productivity values for the individual operational steps. Reinforced concrete would, e.g., require work related to reinforcement, formwork, and concrete pouring. One level further down, one can group different types of building elements, like walls, pillars, and slabs. Finally, the productivity-related values can also be calculated for individual elements or element groups [1].

To assess productivity, it is crucial to compare the target expense values from the construction plan to the actual expense values achieved during a project. This supports determining if the project goals have been fulfilled. Such expense values support construction managers in identifying problems during the project and ensure that project goals will be met. The expense values can be set in comparison with the target expense values of a project to compute the productivity loss of several processes, as formalized in Eq. (4).

$$\Delta Productivity_{loss} = \frac{\frac{1}{Exp_{target}} - \frac{1}{Exp_{actual}}}{\frac{1}{Exp_{target}}} \quad (4)$$

## 4 Proposed Solution

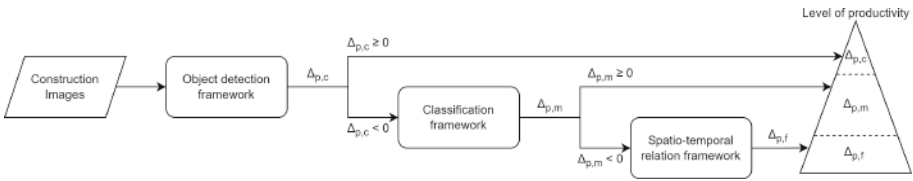

**Fig. 1.** Automated productivity evaluation pipeline

To compute the productivity on construction sites we use photographic images acquired from on-site environments as input source. In this research contribution, we focus on cast-in-place concrete pillars which require multiple individual steps to be built. The images get processed by diverse AI-based frameworks. Depending on the estimated productivity, a more in-depth investigation of a construction process is necessary. Therefore, our proposed pipeline, shown in Fig. 1, is categorizing the productivity deltas into three levels: coarse  $\Delta_{p,c}$ , medium  $\Delta_{p,m}$ , and fine  $\Delta_{p,f}$ . One of the reasons for not computing the fine-grained productivity for all building elements on the total amount of images is to save computational costs and avoid hardware failures.

We apply multiple methods to extract the duration of concreting pillars. However, the equation to compute productivity  $\Delta_p$  stays the same for all using

Eq. (4). The sum of working hours is computed by the number of daily working hours and the size of worker groups allocated to one building component. The volume of the pillars is derived from the BIM model. Having acquired all the site-related information stated above, the expense values and productivity are determined. As the starting point, the duration of the entire pillar construction process is derived by detecting two states of the classified pillars: *start* and *finish* (see Fig. 2). When productivity deltas differ significantly from the expected outputs, more fine-grained methods are applied to dismantle the pillar concreting process in its individual parts: *preparation*, *rebar*, *formwork*, and *finished*.

In case further details are required, spatio-temporal activities (e.g., *standing*, *walking*, *placing*) are identified to quantify the time that was spent working on a particular pillar. The following subsections go more into detail about the productivity analysis on the three different granularity levels. It needs to be mentioned that the selected neural networks represent only one possibility to tackle the given task and might be replaced, e.g. when focusing on other building elements.

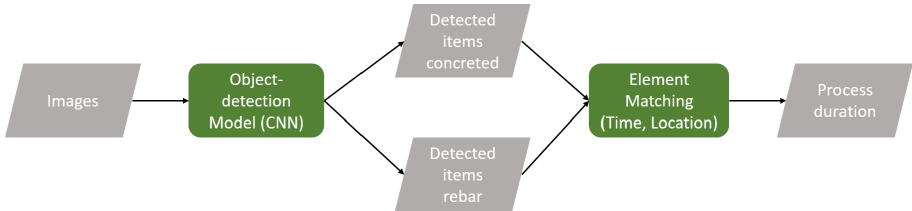
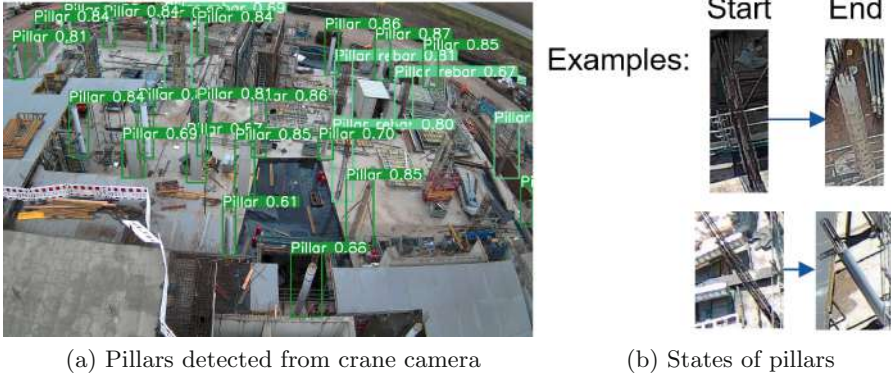

**Fig. 2.** Object detection pipeline

A framework to detect diverse objects on construction sites that forms the starting point of the pipeline was developed by [19]. The approach passes the captured images to a Convolutional Neural Network (CNN) using a one-stage anchor-based detector to identify the type and location of the pillars. Since the location of the detected pillars remains constant, objects can be monitored over multiple images within a construction project to estimate the diverse states of the building components. For example, the beginning of a pillar (rebar) and finish state (concreted column) is captured, as demonstrated in Fig. 3. With the time and location-dependent information, the process duration is estimated allowing productivity computation.

The pillars with exceptionally long construction times and low productivity, highlighted in Fig. 4 are usually of particular interest to better understand issues in the construction process. However, more detailed information is required to identify possible reasons for low productivity. The same applies if pillars are particularly relevant for overall the construction project. In that case, all pillars are examined in further detail.

The identified starting and end times of the pillar construction process are used to narrow down the time interval in which images are analyzed in closer



**Fig. 3.** Start- and finish time computed with object detection

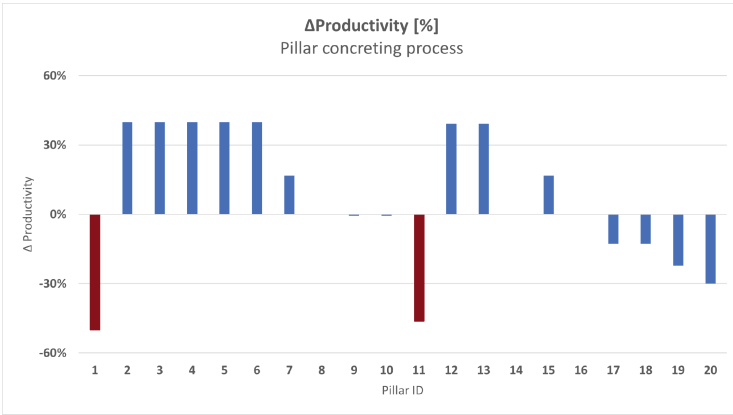

**Fig. 4.** Productivity of the concreting process of sample pillars: Pillars with significantly low productivity  $\Delta_{p,c}$  compared to other values are highlighted in red (Color figure online)

detail. Based on the bounding boxes from the object detection, image sections between start and finish of a building component are cut out from the frequently captured images. These are classified into four different classes according to their current status to identify the operational steps. To do so, the approach developed by [20] is applied, which is described in further detail in the following paragraph.

As depicted in Fig. 5, the input for the image classification are the image sections originating from the object detection. These are passed to a CNN that classifies them according to their status. It differentiates between the status *not started*, *rebar*, *formwork*, and *finished*. The process of pouring concrete is not considered in this approach since it cannot be detected by observing the pillar itself but would require to shift the attention to the detection of the construction equipment like the concrete bucket.



Since the accuracy of the CNN is limited and further decreased by clutter on the construction site and moving objects, some images are wrongly classified. However, having several images of the same pillar is used as an advantage to correct some of the erroneous image classifications. Based on the expected sequence of statuses, the transitions points from one status to the next are identified and then used to correct the status predictions of the CNN. As the final result, the start and end times of every construction phase of the pillar are provided [20]. Even though this gives more insights into the construction process, it still does not allow to directly measure the time that construction workers actively spent working on individual building elements. It also includes the time which a particular pillar remained in a certain status without any working being done.

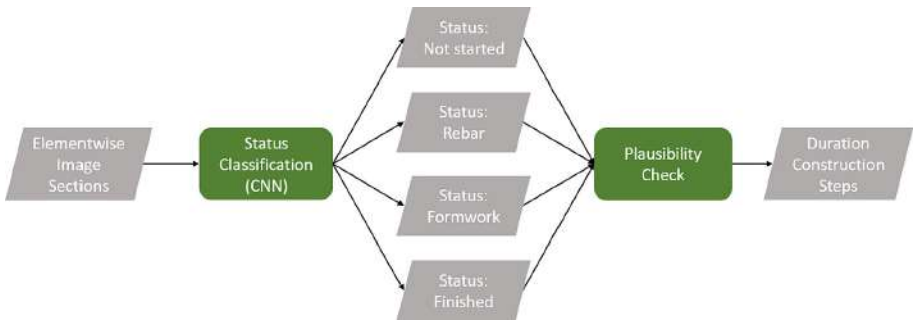

**Fig. 5.** Status classification pipeline for cast-in-place concrete pillars

Similar to the step described beforehand, the operational steps with exceptionally low productivity rates are of particular interest to identify reasons for delays. The level of productivity analysis requires measuring the actual time that construction workers spent working on a specific pillar. This can help, e.g., to distinguish situations where workers were waiting for material deliveries from situations where the delay was caused by faulty execution and therefore required rework. The results from the classification step help to narrow down the time intervals of special importance. The points in time when status changes occur roughly indicated the time when construction personnel has worked on the building element. Observing the construction activities in a predefined time interval before and after the status change will suffice to analyze the construction process. To identify the time that construction workers were working on a specific pillar, an approach is required that takes into account the spatial location of the column but also the movement of the workers. A single image is often not sufficient to identify what a worker is currently doing.

Spatio-temporal action localization networks [21] are a natural fit for this task. They depend upon extracting information from images frame by frame and utilizing the relationships between them to create additional features within the network. The model is trained using the extracted features to create a comprehensive understanding of the activity being performed over time. This allows

for accurate in-depth activity classification, and the identification of the proportion of time when workers are performing specific actions on-site. One of the shortcomings is that action classification networks require multiple frames per second since movements need to be tracked precisely. Based on current data limitations, the spatio-temporal action localization part of the framework has not been implemented yet and remains conceptual at this stage.

## 5 Conclusion

Traditional literature sources that rely on questionnaires may not provide a complete picture of productivity in construction sites, since their primary data source was based on surveys of experts [2]. The proposed objective measurement approach provides more accurate and reliable data.

In this paper, we presented a comprehensive method to measuring productivity for pillar production in construction sites. We gave a detailed introduction to past productivity measurements in on-site environments. In addition, we devised a methodology to compute on-site productivity on diverse levels of granularity based on real-world image data. Finally, we provided a framework using state-of-the-art machine learning methods for a new way to derive productivity on construction sites and support construction management.

While measuring the time taken to complete a specific building element such as a pillar is a useful metric, it is necessary to further extend the approach to detect the factor of time a worker spent efficiently creating a building component. In addition, it is essential to monitor the entire construction site, including all types of building elements, to provide accurate productivity values. By tracking workers' time spent on various building elements, we can obtain valuable insights into their performance. The scope of this objective measurement approach is to identify potential inefficiencies in the construction process, such as delays or bottlenecks, that may be hampering productivity. With this information, construction managers can improve decision-making to optimize their operations and enhance productivity. In conclusion, adopting a comprehensive approach to computing productivity that involves monitoring the entire construction site and utilizing objective measurements is essential. This approach provides valuable data that can help identify inefficiencies, optimize operations, and improve productivity in the construction phase.

**Acknowledgements.** We thankfully acknowledge Innovation Management Bau for their financial support and for providing us access to multiple construction sites to collect valuable data. In addition, we would like to thank Siemens Real Estate and Max Bögl for providing us access to the construction site in Garching. Furthermore, the research presented in this paper has received funding from the European Union's Horizon 2020 research and innovation programme under grant agreement no. 958398, "BIM2TWIN: Optimal Construction Management & Production Control". The authors are very thankful for the support of the European Commission in funding this project.

## References

1. Hofstadler, C.: Bauablaufplanung und Logistik im Baubetrieb. Springer, Berlin (2007). <https://doi.org/10.1007/978-3-540-34321-9.pdf>
2. Hofstadler, C.: Produktivität im Baubetrieb: Bauablaufstörungen und Produktivitätsverluste. Springer, Berlin (2013)
3. You, Z., Wu, C.: A framework for data-driven informatization of the construction company. In: *Advanced Engineering Informatics*, vol. 39, pp. 269–277 (2019)
4. Sami Ur Rehman, M., Shafiq, M.T., Ullah, F.: Automated computer vision-based construction progress monitoring: a systematic review. *Buildings* **12**(7), 1–32 (2022)
5. Peddi, A., Huan, L., Bai, Y., Kim, S.: Development of human pose analyzing algorithms for the determination of construction productivity in real-time. In: *Construction Research Congress*, pp. 886–895 (2009)
6. Torabi, G., Hammad, A., Bouguila, N.: Two-dimensional and three-dimensional CNN-based simultaneous detection and activity classification of construction workers. *J. Comput. Civil Eng.* **36**(4) (2022)
7. Li, H., Chan, G., Wong, J.K.W., Skitmore, M.: Real-time locating systems applications in construction. *Autom. Constr.* **63**, 37–47 (2016)
8. Vähä, P., Heikkilä, T., Kilpeläinen, P., Järviluoma, M., Gambao, E.: Extending automation of building construction - survey on potential sensor technologies and robotic applications. *Autom. Constr.* **36**, 168–178 (2013)
9. Shuyuan, X., Wang, J., Shou, W., Ngo, T., Sadick, A.-M., Wang, X.: Computer vision techniques in construction: a critical review. *Arch. Comput. Meth. Eng.* **28**, 3383–3397 (2021)
10. Schlenger, J., Yeung, T., Vilgertshofer, S., Martinez, J., Sacks, R., Borrmann, A.: A comprehensive data schema for digital twin construction. In: *Proceedings of the 29th EG-ICE International Workshop on Intelligent Computing in Engineering* (2022)
11. Opoku, D.G.J., Perera, S., Osei-Kyei, R., Rashidi, M.: Digital twin application in the construction industry: a literature review. *J. Build. Eng.* **40**, 8 (2021)
12. Chen, X., et al.: Symbolic discovery of optimization algorithms (2023)
13. Li, C., et al.: Yolov6 v3.0: A full-scale reloading (2023)
14. Wang, W., et al.: InternImage: exploring large-scale vision foundation models with deformable convolutions. arXiv preprint [arXiv:2211.05778](https://arxiv.org/abs/2211.05778) (2022)
15. Gong, J., Caldas, C.H.: Computer vision-based video interpretation model for automated productivity analysis of construction operations. *J. Comput. Civ. Eng.* **24**(3), 252–263 (2010)
16. Wang, Z., et al.: Vision-based framework for automatic progress monitoring of pre-cast walls by using surveillance videos during the construction phase. *J. Comput. Civil Eng.* **35**(1) (2021)
17. Greitemann, P.N.: Bestimmung der Bauzeit von Bauprojekten zum Zeitpunkt der Realisierungsentscheidung (2018)
18. Bauer, H.: Baubetrieb 2: Bauablauf, Kosten, Störungen. Springer, Berlin (2013)
19. Pfitzner, F., Braun, A., Borrmann, A.: Object-detection based knowledge graph creation: enabling insight into construction processes . In: *ASCE International Conference on Computing in Civil Engineering 2023*, volume in press, Oregon, US (2023)

20. Schlenger, J., Vilgertshofer, S., Borrmann, A.: Process-oriented progress monitoring of cast-in-place shell constructions based on computer vision. In: 30th EG-ICE International Workshop on Intelligent Computing in Engineering 2023, London, UK (2023)
21. Weinzaepfel, P., Harchaoui, Z., Schmid, C.: Learning to track for spatio-temporal action localization (2015)



# Adaptive BIM/CIM for Digital Twinning of Automated Shotcreting Process

Rehan Khan<sup>(✉)</sup> , Rahul Tomar, and Ahmed Ibrahim

DigitalTwin Technology GmbH, Schaafenstr. 25, 50676 Cologne, Germany  
rehan.khan@digitaltwin.technology

**Abstract.** The development of digital twins (DT) for construction processes requires adequate replication of real-world spaces. Therefore, the use of Building/Civil-Construction Information Modeling (BIM/CIM) for the creation of a digital representation of the physical process and asset plays a vital role. The construction process considered for this research study is shotcrete application and surface finishing during the construction and finishing phases. The research presents the role of adaptive BIM/CIM models for the digital replication of automated shotcreting of civil infrastructure projects. For a digital twin, simulations, and visualizations are essential for the process monitoring and diagnostics alongside the control of the physical asset in real-time through real-world data synchronization. Hence this paper proposes adaptive modeling of civil infrastructures (physical assets) and their associated requirements to facilitate the simulations and visualizations during the digital twinning of the related asset and process. The proposed approach takes into account the creation of adaptive BIM/CIM models at the initial stage such as modeling in parts instead of a single element to facilitate the purpose of the visualizations of the digital model in the later stages of the creation of DT. Additionally, the use of an IFC-based hierarchy is prioritized for the purpose of linking the 3D object elements to the corresponding sensor data and simulations. Other aspects taken into consideration are the registration of robots with GIS measurements and the integration of IoT sensors.

**Keywords:** BIM · Shotcreting · Digital Twin

## 1 Introduction

Shotcrete (sprayed concrete) is used for pneumatic projection at high velocity onto a receiving surface where concrete vibration is not possible, mostly being used in underground mining, tunnel construction, and surface rehabilitation of infrastructures [1]. As per the Sika Sprayed Concrete Handbook [2] the current shotcrete methods depend on operators endangering themselves to un-secured shotcrete to manually examine optimal shotcrete thickness resulting in unreliable examination. Thus, the digitalization of shotcrete application would result in the process being more environmental-friendly, safe, with better quality, and with high cost-effectiveness.

Effective construction digitalization requires appropriate planning synchronization and optimization of technological and logistic elements of construction. Hence, Digital Twin (DT) as an analog-based planning and optimization concept has started to impact the construction industry in recent years [3]. Digital twin uses machine learning, data analytics, and multi-physics simulation to study the dynamics of a given system and therefore the appropriate digital representation of the physical asset or process is essential for DT development [4]. Building Information Modeling (BIM) models are interactive 3D design models of a building or other built infrastructure assets. BIM models primarily encapsulate design intent information [5]. Whereas Civil/Construction information modeling (CIM) is a term commonly used in the AEC industry to refer to the application of BIM for civil infrastructure facilities also called horizontal projects, such as bridges, tunnels, railways, etc. [6]. Thus, BIM models as the digital representation of a construction object or process, contain detailed information about an object such as geometry, function, and visual description which can be used to create the digital replica for the DT. Extensive research by [7] and [8] provides an overview of the application of DT's in the construction industry with the purpose of reducing risk, cost and improving safety and resource efficiency.

Therefore, a construction DT for real-time shotcrete visualization and cognitive simulation of shotcrete application realizes a platform for construction process diagnostics, planning & monitoring. The absence of BIM/CIM models without appropriate digital representation in case of aging infrastructure that requires to be maintained/repaired or for new constructions cause hindrance in developing holistic solutions for automating shotcrete application. Consequently, this article presents an overview of the importance of adaptive BIM as an underlying representation for the digital twining of automated shotcrete application. Since this paper delves into both BIM and CIM for the sake of reference BIM will be used as a reference for both modeling methodologies in the subsequent text of the paper.

## 2 State of the Art

### 2.1 BIM in Digital Twins

A digital twin is a virtual replica of a physical asset, such as a building or infrastructure, that is used to monitor and simulate its behavior and performance. Thus, BIM models are essential to DT's as they are used to create a digital representation of the physical asset, including its geometry, materials, and other important characteristics [9]. The digital twin is then created by linking the BIM model to real-time data from sensors and other sources.

The importance of BIM models for digital twins can be summarized as follows: **Accurate representation:** BIM models provide an accurate representation of the physical asset, which is necessary for creating an effective digital twin, **Improved monitoring:** The integration of BIM models with real-time data from sensors allows for improved monitoring of the asset's performance and behavior, **Simulation:** BIM models can be used to create simulations that allow for better understanding of the asset's behavior under different conditions and scenarios, **Optimization:** By analyzing data from the digital twin, improvements can be made to the physical asset to optimize its performance,

Maintenance: BIM models can be used to create a maintenance plan for the physical asset, which can help to prevent costly downtime and repairs [10]. A research study [11] demonstrated the use of BIM with a geographic information system to develop a web-based DT application for real-time visualization of the asset in an interactive 3D map connected to analytical dashboards to support decision-making. Researchers [12] demonstrated the use of BIM on DT's to simulate, visualize and analyze the construction process to support intelligent building construction management by formulating a reliable construction management plan.

In summary, state-of-the-art research on the importance of BIM models for digital twins has focused on the integration of BIM with other technologies, the use of BIM for more accurate and detailed digital twins, and the application of machine learning and artificial intelligence to analyze data from digital twins.

## 2.2 Shotcrete Digitalization

Shotcrete is a method of applying concrete using a high-pressure hose to shoot concrete onto a surface, often used in construction for building walls, retaining walls, and tunnels. The research study in this section explores and summarizes the most likely application of digital solutions that can help improve the efficiency and accuracy of shotcrete processes. Some digital solutions for shotcrete include:

1. **Laser Scanning:** Laser scanning can be used to create a 3D model of the surface to be covered with shotcrete, which can be used to plan the shotcrete process and ensure accurate coverage, alongside tracking of sprayed concrete.
2. **Augmented Reality:** Augmented reality (AR) can be used to overlay digital information onto the physical surface, allowing the shotcrete operator to see a virtual representation of the surface and ensuring accurate and consistent coverage.
3. **Automated Control Systems:** Automated control systems can be used to control the shotcrete spraying process, ensuring consistent thickness and coverage. These systems use sensors to monitor the thickness of the shotcrete and adjust the spraying process accordingly.
4. **Virtual Reality Training:** Virtual reality (VR) training can be used to simulate the shotcrete process in a safe and controlled environment, allowing operators to practice and improve their skills without the risk of damaging the physical surface.
5. **Digital Documentation:** Digital documentation can be used to track the shotcrete process, including the amount of material used, the thickness of the shotcrete, and other important metrics. This information can be used to improve the shotcrete process and ensure quality control.

The subsequent section presents the application of digital technologies for shotcreting and the proposed method to automate shotcrete application using digital twins as an enabler.

## 3 Proposed Shotcrete Automation

RoBétArmé project aims to automate laborious construction tasks during shotcrete application. Thus, the project work will deliver collaborative construction mobile manipulators, consisting of an (I) Inspection-Reconnaissance mobile manipulator (IRR) to address

fast, high precision modeling and rebar reinforcement through metal additive manufacturing in the preparatory phase and (II) a Shotcrete and Finishing mobile manipulator (SFR) to address autonomous shotcrete application and surface finishing during the construction and finishing phase, respectively.

To this end, RoBétArmé will provide a Digital Twin with advanced simulation tools tailored to the BIM/CIM models used as the basis for representing the physical asset and combining information from robot scanning for an up-to-date model of the construction environment, thus propelling the implementation of the automated construction activities. Thus, the next section describes the role of modeling in the development of shotcrete application DT's.

## 4 Adaptive BIM/CIM Models

Adaptive modeling of BIM models during the initial project stage is necessary to support dynamic simulations and visualizations during the digital twinning stage of shotcreting. Previous studies have explored the aspects of adaptive BIM. The approach of adaptive and parametrized 3D BIM model for linear infrastructure: tunnels was explored by developing Revit families that can be instantiated and adaptively placed along the tunnel alignment to attain a high degree of automation in modeling such as changing shape or attributed values [13]. Another study introduced the concept of Fabrication Information Modeling (FIM), to integrate digital manufacturing in digital design through a combination of additive manufacturing (AM) and BIM methods [14]. The parameters considered to be modeled include material, process, and machine parameters enabling FIM to digitize construction processes that can be executed through AM. Thus, this paper focuses on the role of such BIM models to expedite shotcrete automation.

In the subsequent sections, the requirements for such models from the shotcrete application perspective are presented, followed by the different modeling considerations to make the BIM model adaptive for digital twinning.

### 4.1 Requirements

From the perspective of BIM/CIM models, the processing of modeling itself and then the integration in the DT to develop a digital twin for supporting the automated construction process during the shotcrete application will have some requirements as shown in Table 1. The different ID's mainly define the different requirements that contribute to the development of the digital representation in the DT application. Additionally, the technical requirements represent what a component expects from other components for successful implementation within the scope of the whole research project.

### 4.2 Adaptive Modeling and Interoperability Considerations

This section describes in detail how the different established requirements were considered in the modeling of adaptive BIM models for creating the digital replica of DT's for automated shotcreting on construction sites. For this study, the focus is on shotcrete application on service tunnels, thus the adaptive modeling and its application are done



**Table 1.** Technical requirements

ID	Requirement	Originating Component	Related Parameters	Context
TR-01	3D Geometric model	Design Plan	IFC	3D BIM/CIM model for representing the construction site
TR-02	Reinforcement detailing	Reinforcement plan	Type, location, arrangement	Visualization of reinforcement bar and mesh to facilitate shotcrete simulation
TR-03	IoT sensor 3D model	IoT sensors	Type, shape, connection & location	Modeling of IoT sensors in the BIM model based on their actual site installation
TR-04	Robot simulation specification	Robot coordinates	Robot localization and navigation path	Possibility to support robot platform navigation using elements of the BIM model

for the 3D BIM model of a tunnel. As per this study an ‘*adaptive model*’ would adequately include all relevant DT representations that can be changed through a modular approach as per the desired DT requirements for simulation and visualization of the construction process (shotcreting) based on an end-user centered approach.

### Adaptive Simulation-Oriented Object Modeling

From the DT perspective, adaptive modeling of the infrastructure is essentially aimed to facilitate visualization and simulation. The study by [15], based on practical experience developed parametric and adaptive components to model segment systems for tunnel structures using component families on Revit. In addition, [13] presented a case study to advocate the use of 3D BIM models over traditional 2D design for improving data handling in the tender phase to avoid data loss and adequately represent all the tunnel services that can not be represented in 2D plans.

The adaptive modeling approach adopted in this paper essentially aims to represent established technical requirements in the model that would support simulating and visualizing shotcreting activities on the DT platform. Figure 1 shows the tunnel BIM model wherein different elements are modeled with a segmental approach and a lower level of geometrical detailing. The adopted simulation-oriented modeling approach is primarily based on the use of the IFC data schema and the level of geometric detailing as per the digital model requirements of the DT.

Tunnels can be classified as per their function and their construction method; therefore, the modelling is aimed to be done as per the IFC-Tunnel data model [16] to describe the geometry and semantics of different elements. Shotcrete is often sprayed onto the rock surface immediately after a blast to secure the work environment. The shotcrete

could sometimes have conventional mesh reinforcement or contain fibres. Thus, as per the data model geometry representation of the shotcrete could be modeled as a 3D representation of the shotcrete surface with thickness and the shotcrete area sprayed on the tunnel rock surface called as developed geometry. The IFC classification and hierarchy are vital for the DT representation as they can be used as a point of reference to generate specific simulations and visualizations such as resulting heat maps from sprayed concrete, generation of near real-time meshes to represent the thickness of shotcrete sprayed on the existing surface in the model and 4D planning of shotcrete activities. Additionally, IFC as an open data format can improve information sharing throughout the lifecycle of the digital twin.

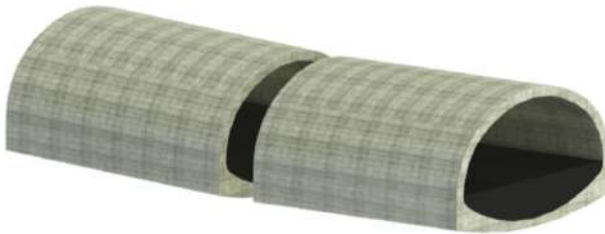

**Fig. 1.** Adaptive modeling (segment-wise) for service tunnels.

Subsequently, another modeling approach adopted is to model the entire tunnel structure based on a higher degree of geometry (LoG). LoG defines the degree/level of geometrical detail that occurs in the tunnel model [17]. The components include (reinforcement, inner lining, waterproofing membrane, and outer segmental lining) that were modeled as individual objects, as represented in Fig. 2. Therefore, the use of LoG while developing the model is linked to the level of DT development as per the user’s requirement with a higher LoG resulting in a more accurate DT representation.

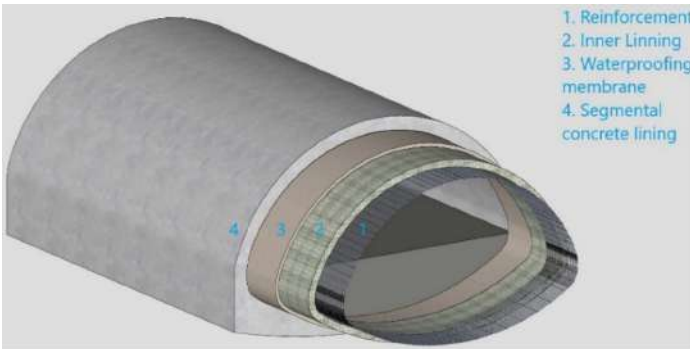

**Fig. 2.** Modeled cross-sectional tunnel components.

### IoT Sensor Modeling

For digital twins, Internet of Things (IoT) devices must interface with BIM and IoT platforms to offer both visualization and actuation possibilities within the temporal and spatial construction site context. Dave et al. [18] proposed a framework integrating built environment data with IoT sensors by integrating open messaging standards (O-MI and O-DF) and IFC models to monitor the indoor environment. Moreover, Khan [19] developed a digital twin by modeling IoT and integrating sensor measurements in the BIM model to support building energy simulations and visualizations in DT through a virtual reality interface.

Thus, this study presents the IoT modeling adopted for the shotcrete application. Figure 3 depicts the 3D model of the IoT sensor that will be installed on the site during the shotcrete application. The sensor will be installed during the preparatory phase of shotcrete application and will measure temperature, humidity, and other relevant parameters for monitoring of construction sites. As illustrated in Fig. 4 the sensors are implanted on the tunnel curvature at adequate distances for proper measurements and accurate digital representation of the physical asset nearby the shotcreting surface. In addition, the model sensors can be defined in the established IFC data schema.

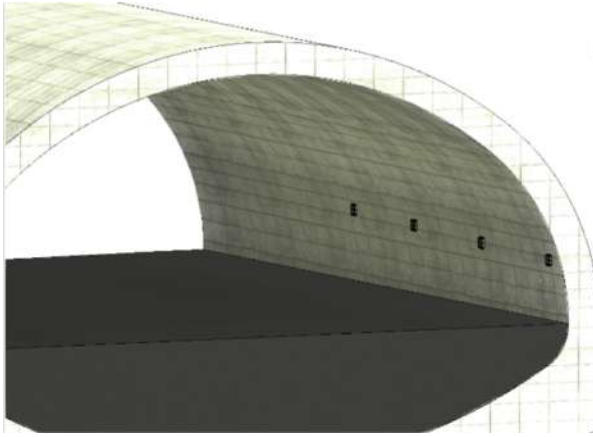

Fig. 3. IoT sensor model.

### Navigation/Simulation of Robots

The notion of exploiting digital BIM models produced in the design phase to provide robotic systems with extensive semantic and geometric knowledge of the construction environment can play a crucial role. A study developed an interface for the extraction of information of data from the BIM model and making it accessible to mobile robotic systems during the construction process to support site logistics [20]. Byers and Razaivalavi [21] developed a method to transfer BIM geometrical data to virtual robots in the simulation environment, to equip robots with prior knowledge and enhance navigation in terms of accuracy and efficiency. In addition, [22] developed Building Information Robotic System (BIRS) to use IFC-based information to generate optimal paths for the safe and autonomous navigation of robots during the construction phase.

The robot path modeled in the BIM model as illustrated in Fig. 5, aims to be reliable and recognizable for the navigation of mobile robots for both IRR & SFR robots. Additionally, the modeled path can be used for the simulation of robotic systems by



**Fig. 4.** IoT sensors in the BIM model.

replicating the actual construction site environment. The main path (light red color) as shown in the figure is modeled for the whole tunnel length with the purpose of facilitating the entry and exit of the robot in the structure alongside robot navigation inside the tunnel. The pit area (yellow color) is also modeled to represent the location where the robot is supposed to localize itself and navigate to this area of interest i.e., the section to be shotcreted. Subsequently, this area can also be used by the robot for surface finishing and quality assessment of the sprayed area.

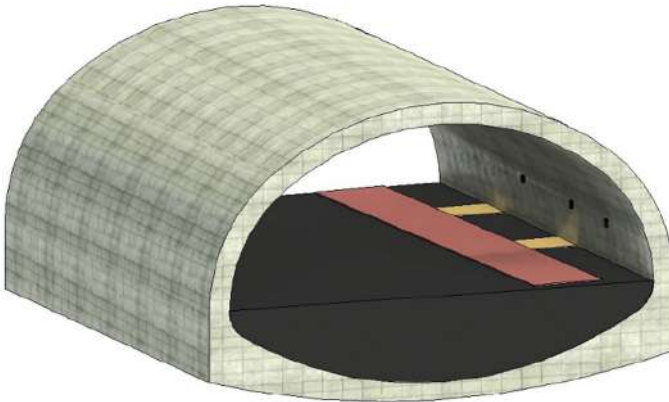

**Fig. 5.** Robot path in the BIM model.

## 5 Conclusion

This paper highlights the importance of the representation of a physical construction site subjected to shotcreting by using adaptive 3D BIM models to fuel digital twin development. By considering representing most aspects of automated shotcreting from the construction environment to IoT sensors and robot navigation, the adaptive model aims to provide holistic representation. Especially the combination of adaptive modeling of individual elements and the automation aspects would result in detailed and appropriate representation for the DT to optimize, control, and monitor the shotcreting process for greener, more cost-effective, and safer solutions. Due to limitations in the scope of the paper, only the adaptive modeling for service tunnels was presented, however, under the research study civil infrastructures in construction & repair phases such as post-tensioned bridges and ground support walls have been investigated as well.

In terms of innovation, the envisioned digital twin application aims to support the automation of shotcreting application by allowing the end-user to visualize, simulate and analyze for near real-time construction monitoring during construction and also to have the capability to examine different inspection and construction scenarios before the actual use of mobile shotcreting robot thus supporting decision making during different stages.

With regard to future work, the research aims to take into consideration additional modeling requirements that will be developed over the duration of the project. Furthermore, the developed adaptive models will be used for the digital twin deployment to realize shotcreting application on construction sites through visualization and real-time control dashboard. Additionally, the study aims to carry out a cost-benefit analysis for the developed adaptive BIM models by applying them on real-life demo construction sites of the research project in comparison to presently uses models for shotcrete application.

**Acknowledgements.** This research work is funded under the European Union's program Horizon 2.4 research and innovation programme under grant agreement no 101058731.

## References

1. Bernardo, G., Guida, A., Mecca, I.: Advancements in shotcrete technology. In: Structural Studies, Repairs and Maintenance of Heritage Architecture XIV, pp. 591–602. WIT Press (2015)
2. Sika Services AG: Sika Concrete Handbook (2020)
3. Tao, F., Zhang, H., Liu, A., Nee, A.Y.C.: Digital twin in industry: state-of-the-art. *IEEE Trans. Ind. Inform.* **15**, 2405–2415 (2019)
4. Rathore, M.M., Shah, S.A., Shukla, D., Bentafat, E., Bakiras, S.: The role of AI, machine learning, and big data in digital twinning: a systematic literature review, challenges, and opportunities. *IEEE Access.* **9**, 32030–32052 (2021)
5. Sacks, R., Brilakis, I., Pikas, E., Xie, H.S., Girolami, M.: Construction with digital twin information systems. *Data-Centric Eng.* **1**, e14 (2020)
6. Cheng, J.C.P., Lu, Q., Deng, Y.: Analytical review and evaluation of civil information modeling. *Autom. Constr.* **67**, 31–47 (2016)

7. Opoku, D.G.J., Perera, S., Osei-Kyei, R., Rashidi, M.: Digital twin application in the construction industry: a literature review. *J. Build. Eng.* **40**, 102726 (2021)
8. Madubuike, O.C., Anumba, C.J., Khallaf, R.: A review of digital twin applications in construction. *J. Inf. Technol. Constr.* **27**, 145–172 (2022)
9. Deng, M., Menassa, C.C., Kamat, V.R.: From BIM to digital twins: a systematic review of the evolution of intelligent building representations in the AEC-FM industry. *J. Inf. Technol. Constr.* **26**, 58–83 (2021)
10. El-Din, M.N., Pereira, P.F., Poças Martins, J., Ramos, N.M.M.: Digital twins for construction assets using BIM standard specifications. *Buildings* **12**, 2155 (2022)
11. Meschini, S., et al.: Toward cognitive digital twins using a BIM-GIS asset management system for a diffused university. *Front. Built Environ.* **8**, 959475 (2022)
12. Jiang, Y.: Intelligent building construction management based on BIM digital twin. *Comput. Intell. Neurosci.* **2021**, 4979249 (2021)
13. Wenighofer, R., Eder, N., Speckmoser, V., Villeneuve, M., Winkler, L., Galler, R.: Adaptive and parameterised 3D BIM model for the tunnel tender and excavation phase. *Geomech. Tunn.* **15**, 272–278 (2022)
14. Slepicka, M., Vilgertshofer, S., Borrmann, A.: Fabrication information modeling: closing the gap between building information modeling and digital fabrication. In: 38th International Symposium on Automation and Robotics in Construction, pp. 9–16 (2021)
15. Schmitt, J., Perkins, M.-K., Lu, C., Khan, D.: Experience with BIM for the modeling of segment systems. *GeoResour. J.* **1**(8), 33–37 (2022)
16. buildingSmart: IFC-tunnel project Report WP2: Requirements analysis report (RAR) (2020)
17. DAUB: Digital Design, Building and Operation of Underground Structures-BIM in Tunneling (2019)
18. Dave, B., Buda, A., Nurminen, A., Främling, K.: A framework for integrating BIM and IoT through open standards. *Autom. Constr.* **95**, 35–45 (2018)
19. Khan, R.A.: Using sensor data from building automation systems in digital twins (2020)
20. Follini, C., et al.: BIM-integrated collaborative robotics for application in building construction and maintenance. *Robotics* **10**, 1–19 (2021)
21. Byers, G., Razavialavi, S.: Layout modeling of the built environment for autonomous mobile robots using building information modeling (BIM) and simulation. In: Modular and Offsite Construction (MOC) Summit Proceedings, pp. 201–208 (2022)
22. Karimi, S., Braga, R.G., Iordanova, I., St-Onge, D.: Semantic navigation using building information on construction sites (2021)



# Using Digital Models to Decarbonize a Production Site: A Case Study of Connecting the Building Model, Production Model and Energy Model

Isabella Deininger<sup>1</sup>(✉), Bernd Koch<sup>2</sup>, Ralph Bauknecht<sup>3</sup>, Mathias Langhans<sup>4</sup>,  
Christoph Falk<sup>5</sup>, Andreas Trautmann<sup>6</sup>, and Konrad Nübel<sup>1</sup>

<sup>1</sup> Chair of Construction Process Management, Technical University Munich, Arcisstraße 21,  
80333 Munich, Germany

isabella.deininger@tum.de

<sup>2</sup> Smart Infrastructure, Siemens AG, Siemenspromenade 2, 91058 Erlangen, Germany

<sup>3</sup> Digital Industry, Siemens Industry Software GmbH, Schwieberding Str. 95-97, 70435  
Stuttgart, Germany

<sup>4</sup> Digital Industry, Siemens AG, Gleiwitzer Str. 555, 90475 Nuremberg, Germany

<sup>5</sup> Smart Infrastructure, Siemens AG, Otto-Hahn-Ring 6, 81739 Munich, Germany

<sup>6</sup> Smart Infrastructure, Siemens AG, Neuenhofstr. 194, 52078 Aachen, Germany

**Abstract.** Rapid growth of digital technology has facilitated industry progress, while industrial CO<sub>2</sub> emissions are a major issue to be confronted. Digital Twins can play a major role but so far, they have no common norms, standards, or models yet. On top of this, the majority in literature uses the term Digital Twin, but only a few sources are really describing a Digital Twin, whereby it describes a bidirectional data transfer between the real model and the software model. Until now, Digital Twins focus on a single area of interest and do not consider the broader challenge of CO<sub>2</sub> emissions. This study gives an example how to predict CO<sub>2</sub> emissions for the operation of a production site by merging three Digital Models (Building, Production, and Energy Model). This approach demonstrates how CO<sub>2</sub> emissions can be reduced during operation by selecting an appropriate production scenario and a specific energy source mix in the planning phase. The core task is to enable energy demand reduction by simulating different production scenarios and to identify the best energy source mix with the resulting CO<sub>2</sub> emissions visible. The case study shows that by merging the three Digital Models, it is possible to create an overview of the expected CO<sub>2</sub> emissions which can be used as a basis for further developments for Digital Twins. However, the case study has shown that only manual data exchange between the models was possible. Further developments enabling a common data exchange and the connection of the interdisciplinary digital models through a shared language are urgently needed to speed up developments for Digital Twins and shape an interdisciplinary industry approach.

**Keywords:** Digital Model · Digital Twin · Building Model · Production Model · Energy Model · BIM · Carbon Dioxide Emissions · Decarbonization

## 1 Introduction

While the manufacturing sector is a key driver for economic growth, the associated industrial emissions have a significant negative environmental impact [1]. The European Union's CO<sub>2</sub> targets are playing an increasingly important role in developing the European industry [2]. Despite recent developments in highly-efficient technologies, reducing CO<sub>2</sub> emissions is proving hard to achieve. In addition to this challenge, there are still numerous individual IT solutions which leads to data silos that do not represent an ideal standardized system landscape to best tackle the CO<sub>2</sub> emission challenge. Digital Twins have a high potential, but there are no common norms, standards, or models. This is because the availability of data, tools for data collection and modeling tools influence the choice of method [3]. Literature shows how most research focuses on improving modeling techniques rather than on merging different Digital Twins. There is a lack of common space in practice where those modeling techniques can exchange useful information. On top of this, the majority of literature uses the term Digital Twin, but only a few sources are really describing a Digital Twin with a bidirectional data transfer and instead refer to a Digital Model or Digital Shadow [4]. Considering the available digital solutions, this case study combines the three Digital Models (Building, Production, and Energy Model) to show a possible decarbonization strategy in the industrial sector and create a foundation for future Digital Twins.

## 2 From Digital Models to Digital Twins

Digital Models are used for design purposes, but when it comes to reconfigurable layouts, Digital Twins become more and more necessary [4]. However, there are diverse and conflicting definitions of Digital Twins and ways of classifying them in literature as well as in common usage, which has prevented the establishment of clear standards or frameworks. What a Digital Twin is and how it is represented varies according to the system of the object they are designed for. Kritzinger et al. have investigated the definitions of Digital Twin and define them according to the level of data integration (from the lowest to the highest): digital model, digital shadow, and digital twin. Hence, a digital model involves a non-automated data flow between the physical and the digital twin. A digital shadow involves a one-way automated data flow, while a Digital Twin requires a two-way automated data flow [4].

### 2.1 Building Model

Building Information Modeling (BIM) is a process supported by various tools, technologies and contracts involving the generation and management of digital representations of physical and functional characteristics. The fundamental purpose of BIM is to create a model of a real object, while the essential function of a Digital Twin of a building is to emulate the object which it reflects [5]. The presented study deals with the Digital Model of the building after the building modeling stage, so that interactions with other Digital Twins in the operational phase are possible.



## 2.2 Production Model

A Digital Model of a production site without a connection to the physical object is a Production Model, while a manufacturing Digital Twin with a bidirectional connection offers the possibility to simulate and visualize manufacturing process parameters, workflows, and logistical aspects [4, 6, 7]. A Digital Twin can simulate especially in the operation phase whether the production schedule is viable from an energy demand perspective. The resulting load curves are used as input for the Energy Model to evaluate the necessary energy supply system.

## 2.3 Energy Model

An Energy Model can simulate future energy processes. With the input of the real energy demand, the main task of the Energy Twin is to optimize the energy supply in terms of decarbonization and the costs over the project lifetime [8]. Energy process simulation software can predict what energy generation technology should be installed to reduce CO<sub>2</sub> emissions [8, 9].

## 3 Methodology

Despite the enormous benefits of Digital Twins in industry, Kritzinger et al. highlights a lack of case studies that apply the concepts in practice to evaluate the benefits in industry [4]. For this reason, this case study combines the proposed Digital Models of a Greenfield for the future development of Digital Twins to demonstrate a decarbonization strategy, while observing the approach pathway outlined in Fig. 1. Because the status quo of the connection between those simulations do not have a direct interface, the case study created the basis and parameters for further developments in Digital Twins, i.e. for a data store and a shared language [10].

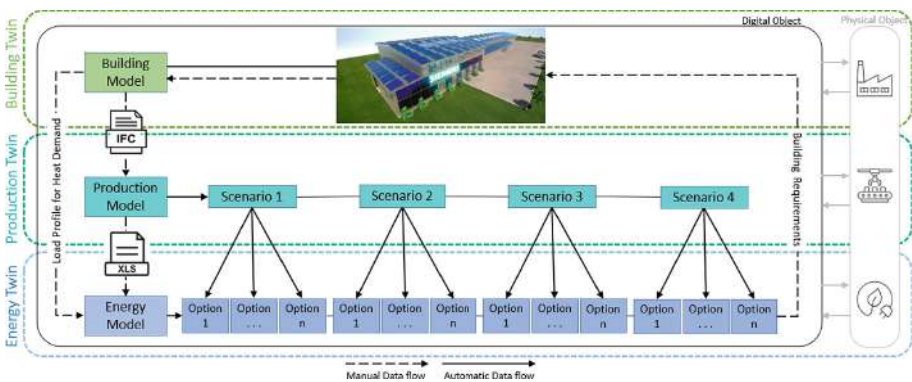

Fig. 1. Digital Model and Digital Twin methodological approach

To find out the requirements of the connections, data was collected from the Digital Models. Based on this data, a simulation of the expected CO<sub>2</sub> emissions was performed.

To achieve the best possible results and to analyze them properly, the case study is motivated by the following question:

*How can the combination of the Building Model, Production Model, and Energy Model be used to simulate the energy demand and associated reduction of CO<sub>2</sub> emissions to run a production site?*

### 3.1 Case Study

This section presents the main conditions and strategy for the case study project of a ‘Cold Brewed Coffee’ factory (see Fig. 2). By using the three mentioned Digital Models, it is possible to cover a wide range of the planning and operation phase of an industrial building.



**Fig. 2.** Digital Model of the production in Tecnomatix Plant Simulation by Siemens

To develop defined input parameters from the Building Model, an architectural model was designed first. After the production building had been modeling in ArchiCAD and the geometries and spatial possibilities of a production were obtained, the IFC Model (Industry Foundation Classes) was transferred to the ‘Siemens Tecnomatix Plant Simulation’ software to obtain the energy demand of the production process. After a first simulation of the production process was performed, the purpose was to find out which adjustments could be made to reduce the energy demand and how to level the load peaks. Therefore, the following optimizations of the production simulation were made based on specific production variations:

To utilize the optimum of the given building geometries, a 3-shift system was operated on all days of the week (Monday to Sunday) in the *first production scenario*. It was assumed that standard conveyors of three parallel filling lines run continuously.

To save energy at the equipment within the production process, the next trial with an automatic stop of the conveyor systems was considered as the *second production scenario*. This means that the operation is load-dependent, and the drive units of the

conveyors are controllable using sensors for occupancy. This was the first step to reduce energy consumption without negatively affecting the output rate.

In the *third production scenario*, only two work shifts were run during the day, with no shift on Sundays. The aim here was to maintain an almost constant production volume with reduced shift costs and most of the production during the day (energy from photovoltaics (PV)).

Due to the resulting high CO<sub>2</sub> emissions, the additional line was removed in the *fourth production scenario*, while knowing that the throughputs could not be maintained with the same shift schedules.

To cover the load peaks and to obtain information about the required energy sources, the energy demand was put into ‘Siemens Power System Simulator for Distributed Energy (PSS®DE)’, which is a simulation software that helps to optimize the value of the energy infrastructure investments to maximize the reduction of CO<sub>2</sub> emissions (see Sect. 2.3). While all necessary properties could be transferred from the Building Model to the Production Model through the IFC interface, no building properties could be transferred via IFC to the energy simulation, which is why the heat loads had to be transferred manually from the building as heat load profiles. In addition, further boundary conditions had to be entered manually to obtain an accurate energy simulation. So, the load profiles (kWh) from the process energy of the Production Model could only be imported into the Energy Model via XLS file.

## 4 Results and Discussions

This section presents the results following the described approach (see Fig. 1) and the central research question. First, the resulting CO<sub>2</sub> emissions of the investigated four production scenarios were compared to carry out further detailed observations on the lowest CO<sub>2</sub> production scenario from the four production scenarios. Therefore, the energy simulation PSS®DE can determine possible energy mix variations based on the input parameters and the required energy demand. PSS®DE categorizes and differentiates various options depending on the different energy sources (see Fig. 4) and generates at least one option with no CO<sub>2</sub> emissions (see Fig. 3). The version with the lowest CO<sub>2</sub> emissions (0,00 to CO<sub>2</sub>/year) is the 1<sup>st</sup> option, whereby the CO<sub>2</sub> emissions increases up to the 10<sup>th</sup> option. The worst option in this consideration regarding to CO<sub>2</sub> emissions is the status quo, which uses the conventional natural gas boiler for the thermal load and electricity from the public grid. This was based on the emissions of the German electricity mix. At the time of the analysis, these amounted to 201 gCO<sub>2</sub>/kWh for natural gas and an average value of 420 gCO<sub>2</sub>/kWh for the CO<sub>2</sub>-emissions mix factor electricity mix [11, 12].

As already mentioned, the fourth production scenario does not achieve the desired production output, which is why the next lowest CO<sub>2</sub> production scenario (3. Production Scenario) is considered in more detail below. The goal of the energy simulation was to use as much renewable energy as possible on-site. Under the main condition that self-produced energy ensures coverage of the energy load, the options from 1 to 6 could be taken into consideration. Due to space constraints in this paper, the following comparative analysis with the most CO<sub>2</sub>-neutral option was narrowed down to an ideal option. After

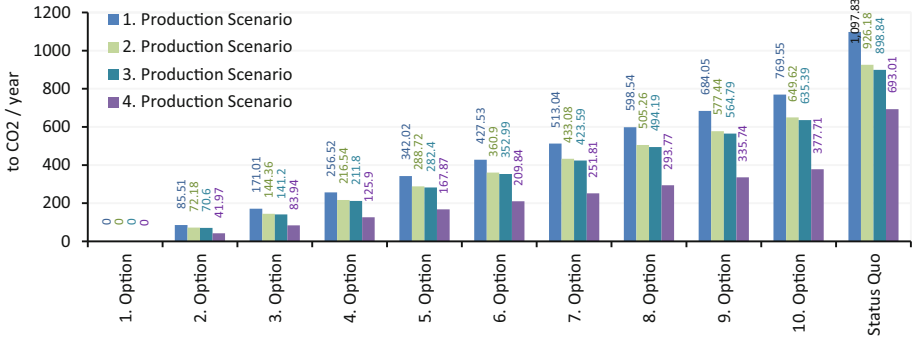

Fig. 3. CO<sub>2</sub> emissions of the considered production scenarios

a plausibility check regarding the operable renewable energies, the energy source mix from option 6 proves to be realistic for the project. Considering the 1<sup>st</sup> option and at the same time the 6<sup>th</sup> option for comparison, the following energy source mix is obtained as shown in Fig. 4:

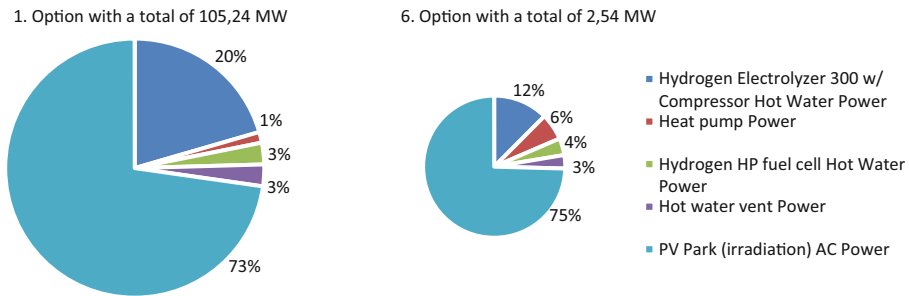

Fig. 4. Energy Source Mix for Option 1 and 6 based on Production Scenario 3

The high amount of the PV power results from the optimizer in PSS@DE. The energy simulation shows that the decarbonization strategy attracts the most renewable energy sources (e.g., from the PV) park). Because only locally generated energy is considered to be CO<sub>2</sub> neutral, it becomes apparent that a very large PV powerplant is needed. If this is not possible on-site and zero CO<sub>2</sub> emissions are intended, a non-local generation should be considered, e. g. with a Power Purchase Agreement (PPA). Regarding to the results of the energy simulation, generation should correlate with the load profile, otherwise higher storage capacities are needed. This means that during the day and during the summer months the demand should be covered by using photovoltaic power generation, while in winter the variants with low CO<sub>2</sub> emissions are bridged with hydrogen as a storage component.

In addition to the energy sources shown in Fig. 4, further energy sources were also taken into account in the energy simulation, but they were not selected as a consequence of the energy simulation. This is since PSS@DE can automatically exclude non-profitable

energy sources. Thus, it should be noted that among the renewable energy sources, 0 kW was obtained from wind power. This is explained by the fact that the specific costs for wind power on-site are relatively high compared to PV.

The CO<sub>2</sub> optimizations examined in this article are in favor of increased investments and reduced operational cost. This is aimed to minimize potential changes in energy cost in the future. However, it is essential to weigh the cost of generation on-site (with Capital Expenses CAPEX) against the cost of energy on the market (Operational Expenses OPEX). Consequently, the way of implementing the reduction of CO<sub>2</sub> emissions depends on the decision-maker to what degree someone is willing to invest in the possible sustainable technologies and to the allowed legal boundaries. Therefore, the study evaluated how much of the self-generated renewable energy made economic sense. However, a more detailed consideration of the costs is out of our scope since numerous factors would influence the cost calculation.

## 5 Conclusions

Industrial production makes a significant contribution to CO<sub>2</sub> emissions, and while many individual digital solutions are available, there is a lack of a holistic digitalization for a decarbonization strategy in an industrial environment. Challenges for Digital Twins involve standardization, multidisciplinary collaboration, and a solid basis from Digital Models. This study has shown the current data transfer between three Digital Models for a transparent visualization of a possible decarbonization through the use of future Digital Twins.

By using the three Digital Models it was possible to cover a wide range of the planning phases of a reference production facility “Cold Brewed Coffee”. Four different production scenarios were investigated and compared regarding energy demand, and respective CO<sub>2</sub> emissions based on the energy simulation. As already pointed out in literature and hereby confirmed with the case study, there is a lack of frameworks, and it became apparent that it was a challenge to combine the Digital Models because of their different fields of focus. Thus, this study clearly identified the gaps regarding an automatic transfer of the input parameters to other Digital Models. There must be an interface between the interdisciplinary fields on the part of each level of integration (Digital Model - Digital Shadow - Digital Twin) to transmit and take into account important building parameters (transmission losses, building envelope, thermal insulation, etc.) to other models and to provide a more detailed assessment of energy performance. Because there is a lack of common space in practice where those models can exchange useful information, further work is encouraged to define an interface for the connection of the individual Models in terms of standard information for data exchange and automation to avoid IT island solutions.

**Acknowledgments.** All authors have read and agreed to the published version of the manuscript and declare no conflict of interest.

The authors wish to express their sincere gratitude and appreciation to Falkenstein Projektmanagement GmbH for the Building Model and due to all members of the project team from Siemens AG for their valuable contribution: Andreas Trautmann, Andy Manley, Bernd Koch,

Christian Falkenstein, Christoph Falk, Christoph Neher, Martin Kautz, Mathias Langhans, Nicolas Albornoz, Ralph Bauknecht, Ralph Brecht (in alphabetic order).

## References

1. Sabine, C., Ciais, P., Jones, C.: Ask the experts: The IPCC fifth assessment report. *Carbon Manag.* **5**(1), 17–25 (2014)
2. European Commission: Der europäische Grüne Deal. Mitteilung der Kommission an das Europäische Parlament, den Europäischen Rat, den Rat, den Europäischen Wirtschafts- und Sozialausschuss und den Ausschuss der Regionen. Brussels, 2019/12/11
3. Alavi, H., Vecchia, L.F.D., Forcada, N.: Digital twins' applications for building energy efficiency: a review. *Energie* **15**, 7002 (2022)
4. Kritzinger, W., Karner, M., Traar, G., Henjes, J., Sihm, W.: Digital twin in manufacturing: a categorial literature review and classification. *IFAC-Papers OnLine* (2018)
5. Hosamo, H.H., Imran, A., Cardenas-Cartagena, J., Svennevig, P.R., Svidt, K., Nielsen, H.K.: A review of the digital twin technology in the AEC-FM industry. *Adv. Civ. Eng.*, 2185170 (2022). <https://doi.org/10.1155/2022/2185170>
6. Resman, M., Turk, M., Herakovi, N.: Methodology for planning smart factory. *Procedia CIRP* **97**, 401–406 (2021)
7. Schuh, G., Kelzenberg, C., Wiese, J., Kessler, N.: Creation of digital production twins for the optimization value creation in single and small batch production. In: 53<sup>rd</sup> CIRQ Conference on Manufacturing Systems (2020)
8. Yu, W., Patros, P., Young, B., Klinac, E., Walmsley, T.G.: Energy digital twin technology for industrial energy management: classification, challenges and future. *Renew. Sustain. Energy Rev.* **161**, 112407 (2022)
9. Strielkoswki, W., Rausser, G., Kuzmin, E.: Digital Revolution in the Energy Sector: Effects of Using Digital Twin Technology. In: Kumar, V., Leng, J., Akberdina, V., Kuzmin, E. (eds.) *Digital Transformation in Industry – Digital Twins and new business models. Lecture Notes in Information Systems and Organisation*, vol. 54, pp. 43–55. Springer, Cham (2022)
10. Erkoyuncu, J.A., del Amoa, I.F., Ariansyaha, D., Bulkaa, D., Vrabic, R., Roy, R.: A design framework for adaptive digital twins. In: *CIRP Annals - Manufacturing Technology*, vol. 69, pp. 145–148 (2020)
11. Bundesamt für Wirtschaft und Ausfuhrkontrolle: Informationsblatt CO<sub>2</sub>-Faktoren. Bundesförderung für Energie- und Ressourceneffizienz in der Wirtschaft – Zuschuss. 1.1. (2021)
12. Umweltbundesamt: Entwicklung der spezifischen Treibhausgas-Emissionen des deutschen Strommix in den Jahren 1990–2021. *Climate Change* 15/2022 (2022)

# **Construction Equipment**



# Evaluation of Different IIoT Transmission Technologies for Connecting Light Construction Equipment in Outdoor Areas

Adrian Josef Huber<sup>(✉)</sup> and Johannes Fottner

Technical University of Munich, 85748 Garching, BY, Germany

[adrian.huber@tum.de](mailto:adrian.huber@tum.de)

<https://www.mec.ed.tum.de/fml>

**Abstract.** Within this paper, an evaluation of possibilities to connect light construction equipment operating in real-world scenarios to the Industrial Internet of Things (IIoT) is conducted. The focus is on implementing data acquisition and transmission technologies to acquire equipment usage data. Hereby, special attention is given to differences in transmission technologies before the backdrop of their suitability for the use case, focusing on parameters such as energy consumption, cost efficiency, and robustness. The main findings include that Bluetooth Low Energy (BLE) and Low Power Wide Area Networks (LoRaWANs) are well suited for the remote monitoring of light construction equipment. Additionally, creating a data pipeline where devices use already existing infrastructure on larger construction equipment is recommended. Finally, cellular transmission technologies such as NB-IIoT and LTE-M are advanced as solutions when the transmission's reliability and independence from existing infrastructure are focused upon.

**Keywords:** IIoT · CPS · construction site · remote monitoring · light construction equipment

## 1 Introduction

### 1.1 Initial Situation

A lack of transparency regarding usage times, application areas, and general use scenarios within the construction industry is characteristic, especially for lighter and smaller construction equipment. Light construction equipment is defined as equipment that can be held or guided by hand or remote control and does not offer a ride-on option. Additionally, its weight does not exceed 1500 kg [1]. In practice, while most of the time not representing a significant cost factor, it nonetheless is vital for accomplishing certain construction tasks. Between light construction equipment and larger, more complex equipment such as excavators, the cost factor spans the area of several magnitudes, resulting in

© The Author(s), under exclusive license to Springer Nature Switzerland AG 2024

J. Fottner et al. (Eds.): CLEaR 2023, LNCE 390, pp. 79–88, 2024.

[https://doi.org/10.1007/978-3-031-44021-2\\_9](https://doi.org/10.1007/978-3-031-44021-2_9)



the former exhibiting a low-involvement character from a customer's point of view [2,3]. Conversely, the need to develop a deeper understanding of the usage of light construction equipment has not only, from a customer's point of view, been negligible [2,4].

These preconditions lead to a stagnation of efforts regarding the collection of real-world usage data, the derivation of transparent work cycles and guidelines regarding equipment utilization for specific use cases utilizing various types of light construction equipment [1]. To address the issue and close the prevailing knowledge gap, developing a scalable and cost-effective way to collect usage data from real-world use cases is necessary. This paper gives an overview of current Industrial Internet of Things (IIoT) solutions concerning their suitability for connecting light construction equipment, focusing on different transmission technologies and their merit concerning the implementation of remote monitoring applications.

## 2 State of Science

Firstly, the current state of science in the field of transmission technologies in terms of its relevance for the use case at hand is discussed. The technologies are then examined in terms of their suitability for the application on the basis of their specific requirements and corresponding criteria. These are additionally weighted in order to compare the different technologies in a targeted manner, both on the basis of their performance in general and on the relevance of the individual criteria in comparison to one another [5,6]. The solutions that perform best in the multi-criteria comparison are then selected and examined in more detail, especially concerning their applicability from a practical point of view. The paper closes by proposing specific solutions for the remote monitoring and data collection of utilization parameters within real-world environments.

### 2.1 Theoretical Background and Definitions

In recent years, multiple ways of interconnecting devices in the context of cyber-physical systems (CPS) have found industrial application [7]. In the following, the central feature of a cyber-physical system is understood to be the linking of the physical equipment in real world environments and a corresponding digital image containing all relevant process information and machine parameters [8–10].

While this form of intelligent networking has become commonplace within production environments, in non-locally bound, constantly changing environments, which on top of that predominantly take place in outdoor areas, solutions that make sense both from a technical point of view and an economic point of view while facing intense cost-pressure are still under development [10]. Additional problems when implementing this within IIoT infrastructures in dynamically changing environments arise from the fact that communication devices must be mobile-ready and function with only rudimentary infrastructure. Thus,

the framework conditions are completely different from those with locally stable environments.

For some time now, telematics solutions have been installed as a standard in large construction equipment to generate added value for both the user and the manufacturer in terms of process optimization, equipment monitoring, and developing an understanding of the equipment within various construction tasks [11].

In contrast, when looking at lighter construction equipment, the transmission cost of the cellular network and the need to implement a telematics system with a CANbus interface is all but reasonable when measured against the cost of the equipment itself. Hence, compared to existing solutions, the challenge of creating a CPS out of light construction equipment is twofold: On the one hand, the application takes place in a dynamically changing environment on equipment that offers very limited interfaces and installation space. On the other, the cost of implementing a data pipeline is difficult to justify compared to equipment costs.

### 3 Method and Evaluation

The most common networking technologies currently employed to transmit data for similar IIoT scenarios include, but are not limited to, LoRaWAN, WIFI, RFID, BLE, Sigfox, ZigBee, NFC, QR-Codes as well as a multitude of cellular standards such as NB-IoT, LTE-M, 2G, 3G, 4G and 5G [12–15]. Common features for selection and differentiation include range, transmission frequency, transmission latency, energy requirements, and the cost factor [13,16,17].

### 4 Results: Applying the Technology to the Use Case

Pursuing the initiated methodology further, various transmission technologies' different requirements and degrees of fulfillment are visualized graphically with radar charts in Fig. 1.

To generate these, the most relevant requirements were worked out based on the specific use case and rated on a scale of 1–10 [5,6]. These were specified and adopted in accordance with criteria previously defined in IIoT deployment scenarios [16]. The degree of fulfillment of the examined technology is then reflected in the colored area of the respective dimension. To keep the figure concise and vivid, only six technologies were examined to prepare the diagrams. This is also due to a pre-selection which was carried out based on exclusion criteria. Setting a threshold for costs as well as high energy requirements leaves technologies such as Wi-Fi out of the investigation. Sigfox is excluded as it is a proprietary technology of a single company [18]. As ZigBee finds its predominant application within consumer applications and smart home environments, exhibiting high maintenance costs next to security and network stability issues, it is excluded as well [19]. Furthermore, since NB-IoT and LTE-M are often installed together on a single module, they were summarized into one chart [20]. The degree of

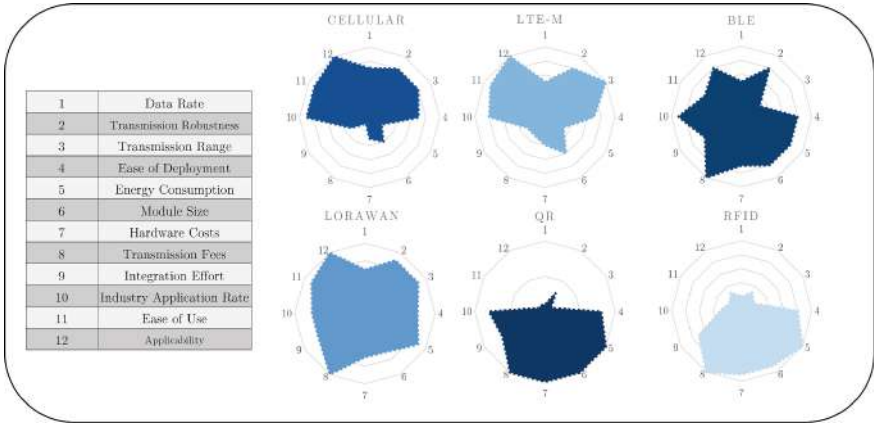

Fig. 1. Transmission Technologies

Attributes	Data rate	Transmission Robustness	Transmission range	Ease of Deployment	Energy Consumption	Module size	Hardware costs	Transmission fees	Integration effort	Industry application rate	Ease of use	Applicability	Sum
Importance	7	8	9	6	8	8	7	8	7	8	7	7	
QR	1	3	1	8	10	10	10	10	7	8	1	1	485
RFID	2	3	2	8	10	9	9	10	7	3	2	2	494
BLE	5	8	8	8	8	8	7	10	6	9	6	8	600
LoRaWAN	5	7	7	6	7	5	5	8	8	8	7	8	555
Cellular 2G, 3G, 4G	7	8	8	7	2	4	3	1	3	9	9	10	480
LTE-M	5	8	10	7	2	6	4	2	3	8	9	10	527
NB-IoT	4	8	10	7	4	6	5	4	3	8	9	10	545

Fig. 2. Comparison Requirements-Technologies

fulfillment for each technology within Fig. 1 and Fig. 2 was deduced according to Table 1.

The multiplication of the weighting with the requirement fulfillment of the respective technology can be seen in Fig. 2. Therein, a sum representing the fulfillment degree of each technology for the use case is calculated.

The results from Fig. 1 and Fig. 2 reveal that BLE showcases an especially high degree of fulfillment. Additionally, LoRaWAN and NB-IoT/LTE-M are analyzed in more detail in the following. The aim is to conceptualize a potential solution for the use case’s requirements employing each of the selected transmission technologies, thereby determining its respective suitability for the specific application.

### 4.1 Multiple Operation Scenarios: LoRaWAN

Regarding LoRaWAN, multiple network scenarios and operation modes exist, necessitating a more detailed investigation [14]. A general differentiation can be made between the public network of a provider, a local private network, and open community based LoRa networks.

**Table 1.** Comparison of Different Transmission Technologies

Technology	Source
QR	Pandya & Galiyawala, 2014; Rouillard, 2008; Lee et al., 2018 [21–23]
RFID	Chawla & Ha, 2007; Xie et al., 2014; Finkenzeller, 2015; Weinstein, 2005 [24–27]
BLE	Dian et al., 2018; Yang et al., 2019; Jeon et al., 2018 [28–30]
LoRaWAN	Kainz & Bürger, 2016; Wang et al., 2022; Deutsche Telekom AG, 2021; Mekki et al., 2019 [14, 17, 31, 32]
Cellular 2G, 3G, 4G	Liberg et al., 2017; Rosalina, Munadi, & Fahmi, 2015; Azari, Rosas, & Pollin, 2019 [33–35]
LTE-M and NB-IoT	Wang et al., 2022; Vodafone Group, 2023; Mikulasek et al., 2022; Deutsche Telekom AG, 2021; Mekki et al., 2019; Guest, C. 2022; Deutsche Telekom IoT GmbH, 2023 [14–16, 31, 32, 36, 37]

Deciding which network operation mode is most suited to the demands of the use case at hand constitutes the fundamental decision regarding LoRaWAN, as it significantly influences network and transmission properties and associated costs. Keeping initial investments at a minimum and ensuring adequate network coverage requires an open community network or the proprietary network of a solution provider. The decision then comes down to whether a community network’s potential security risks justify a provider network’s additional costs [14]. However, once a suitable operation mode has been established, LoRaWAN offers unique advantages compared to other transmission technologies. These mainly include its wide range compared to Bluetooth, low to no transmission cost and easy installation compared to cellular, extensive community support and hardware solution providers, and relatively low energy demands, enabling self-sufficient systems [32].

## 4.2 Cellular Transmission

In the following, different cellular transmission standards are compared concerning their suitability. The summary of NB-IoT and LTE-M, made initially because they are often installed together on cellular modules, is split in the following because the technologies vary in detail [20, 37]. While both NB-IoT and LTE-M are based on the LTE standard and use similar frequency bands, significant differences can be found in the frequency bandwidth (180 KHz for NB-IoT versus up to 1.4 MHz for LTE-M) and thus also the transmittable data rate [16, 31].

Concerning a few key parameters with regard to the use case at hand, such as network coverage, power consumption, mobility (i.e., changing from one cell to another), as well as global roaming, LTE-M constitutes the most compelling option [16]. Above all, the low power consumption and low costs make LTE-M an ideal transmission standard for remote monitoring tasks. Next to the in some

countries still insufficient network coverage, one main disadvantage compared to LTE CAT 3–12 standards is the limited data rate, both in the uplink and in the downlink [38]. Whereas NB-IoT is characterized by robust transmission even under difficult reception conditions, end-to-end encryption, high scalability, and low energy consumption, LTE-M can transmit even higher data rates without compromising massively on costs, energy consumption, or signal reception [15, 16]. Consequently, LTE-M, like NB-IoT, also meets requirements for low energy consumption and high object penetration [37]. While NB-IoT is predestined for IIoT applications where low data rates suffice and networked devices are rather static, i.e., display relatively long intervals between uploads, LTE-M is ideally suited for applications where there is also a need for larger bandwidths and data volumes, like for example firmware updates [36]. From the results of this paper, NB-IoT can be considered a viable alternative if the equipment is rather static on construction sites with long time spans between upload intervals, and firmware updates are optional. If, however, occasional updates are necessary and high mobility of the individual equipment can be observed, LTE-M offers better properties.

### 4.3 Bluetooth Low Energy

To conclude the detailed analysis, BLE is examined in more detail. As it scored highest within the analysis, it should be the most compelling solution for the use case. Firstly, the main differences between Bluetooth Classic and Bluetooth Low Energy are briefly outlined as the two serve different purposes and applications. Bluetooth Classic is tailored for multimedia streaming applications, while BLE is focused on IIoT applications where low-volume sensor data needs to be transmitted frequently with a high time resolution. Whereas Bluetooth Classic employs a one-to-one communication framework, BLE uses a one-to-many communication [29].

Looking at BLE in detail, challenges emerge. First up, its low range makes reliable, consistent, and cyclical data transmission into back end solutions difficult. The crucial point regarding the data pipeline from a user’s point of view is the need to have a gateway, most commonly a mobile phone, close to each BLE Device. Whereas BLE has no transmission cost, uploading the data via mobile phones does incur cellular transmission costs, albeit often negligible.

In the case of remote monitoring of light construction equipment BLE is usually implemented in the form of so-called BLE Beacons which are mounted or retrofitted on existing equipment. As hardware prices generally range between 5–30€ for a customized industrial solution, they constitute a viable and cost-efficient solution [39]. Being able to tailor an individual BLE Beacon specifically for the application, suitable sensors can be selected, durability requirements specified, and energy storage capacities based on sampling rates calculated. Their versatility and self-sufficiency make Beacons ideal for monitoring usage data from various devices in many different environmental conditions, keeping efforts to adapt the technology to specific equipment needs and preexisting interfaces at a minimum.

## 5 Discussion and Conclusion

Looking closer at construction sites and daily use profiles of light construction equipment promises unique opportunities to combat labor shortages and reduce construction costs [40]. Nonetheless, efforts to understand the usages of light construction equipment remain lackluster, with manufacturers offering a bare minimum in equipment connectivity. During this investigation, an evaluation of possibilities to implement an IIoT infrastructure to acquire usage data from light construction equipment from real-world scenarios is conducted. Detailed attention is given to differences in transmission technologies and their suitability for the use case. Comparing common industry protocols and showcasing how the transmission technology affects the entire system environment, the importance of thoroughly analyzing existing preconditions to find the optimal solution is highlighted. Underlining key differences in transmission technologies and, perhaps even more importantly, differences in their applicability marks the final step of the investigation, giving a broader overview than only the main subject matter. Stacking up the advantages and disadvantages of the transmission technologies against one another as well as looking at their practicability, a few takeaways can be noted. Whereas not one technology can be made out to fulfill every requirement perfectly, others can be clearly shown to have significant disadvantages. Especially technologies such as RFID, NFC or QR codes might be great regarding cost and energy usage. However, their feasibility in practice for remote monitoring purposes from a customer's point of view is more than limited. IIoT-specific solutions containing protocols specifically developed for industrial use cases, such as LoRaWAN, BLE, LTE-M, and NB-IoT, are much more viable candidates. A general question within the evaluation, independent of the specific transmission technology, comes down to the corresponding, in some cases pre-existing, infrastructure. As industrial applicability and scalability should, in most cases, be focused upon, the solution must stand out above all in terms of its efficiency regarding cost and implementation effort.

One main question to be asked regarding the connectivity solution of light construction equipment is the following: Whether a technical solution requiring additional gateways but exhibiting meager data transmission costs is more advantageous due to being more cost-efficient or if each piece of equipment needs to act as its own gateway. For the former case, a recommendation for BLE can be given. For the latter, LTE-M is an optimal solution. As modules often contain NB-IoT alongside LTE-M with minimal added costs, a combined module may make sense, changing operation mode, i.e., transmission technology, cyclically based on individual requirements.

The main limitations of the work simultaneously constitute the main points for future research. They primarily include that the overview of current transmission technologies remains incomplete. Albeit including the most common transmission technologies, the analysis is only partially exhaustive, leaving room for future examinations. More extensive research within the area is needed to formulate a concise recommendation. Even though extensive groundwork has been carried out, the work remains theoretical. A detailed comparison and examina-

tion of different transmission technologies within real-life construction equipment scenarios might enhance the expressiveness of the study. Especially field testing in real construction scenarios, before the backdrop of preconditions unique to construction sites, will provide insightful results.

## References

- Schöberl, M., Offinger, S., Goldfuß, T., Kessler, S., Fottner, J.: ISARC. Proceedings of the International Symposium on Automation and Robotics in Construction, pp. 183–190. IAARC Publications, Waterloo (2022)
- Fuchs, A.: Baumaschinen Müssen Laufen und Geld Verdienen. *ATZOffhighway* **6**(1), 18–22 (2013). <https://doi.org/10.1365/s35746-013-0056-4>
- Wacker, N.: Electric construction equipment. Our zero emission solutions. Ed. by Wacker Neuson SE (2022). <https://www.wackerneuson.de/zero-emission>. Accessed 14 Mar 2023
- Kessler, S., Wimmer, J., Günthner, W.: Baumaschinen Flottenmanagement mit Telematik - Benefit für den Betreiber. Lehrstuhl fml, Technische Universität München, München (2020). [https://mediatum.ub.tum.de/doc/1188338/fml-20131230\\_530\\_export.pdf](https://mediatum.ub.tum.de/doc/1188338/fml-20131230_530_export.pdf). Accessed 14 Mar 2023
- Bellinger, B., Vahl, G.: Unternehmensbewertung in Theorie und Praxis. Springer, Wiesbaden (2013). <https://doi.org/10.1007/978-3-322-83593-2>
- Kühnapfel, J.B.: Vorgehen bei der Durchführung einer Nutzwertanalyse. In: Kühnapfel, J.B. (ed.) Scoring und Nutzwertanalysen, pp. 17–100. Springer, Wiesbaden (2021). [https://doi.org/10.1007/978-3-658-34810-6\\_4](https://doi.org/10.1007/978-3-658-34810-6_4). Accessed 16 Mar 2023
- Pivoto, D.G., de Almeida, L.F., da Rosa Righi, R., Rodrigues, J.J., Lugli, A.B., Alberti, A.M.: Cyber-physical systems architectures for industrial Internet of Things applications in Industry 4.0: a literature review. *J. Manuf. Syst.* **58**, 176–192 (2021). <https://doi.org/10.1016/j.jmsy.2020.11.017>. Accessed 14 Mar 2023
- Wang, L., Törngren, M., Onori, M.: Current status and advancement of cyber-physical systems in manufacturing. *J. Manuf. Syst.* **37**, 517–527 (2015). <https://doi.org/10.1016/j.jmsy.2015.04.008>. Accessed 14 Mar 2023
- Broy, M., et al.: Cyber-Physical Systems: Innovationsmotoren für Mobilität, Gesundheit, Energie und Produktion. Springer, Heidelberg (2011). <https://doi.org/10.1007/978-3-642-27567-8>. <http://nbn-resolving.org/urn:nbn:de:bsz:31-epfficht-1573744>. Accessed 14 Mar 2023
- Pistorius, J.: Industrie 4.0 - Schlüsseltechnologien Für Die Produktion: Grundlagen \* Potenziale \* Anwendungen. Springer, Heidelberg (2020). <https://doi.org/10.1007/978-3-662-61580-5>. <https://ebookcentral.proquest.com/lib/kxp/detail.action?docID=6245733>. Accessed 14 Mar 2023
- Monnot, J.M., Williams, R.C.: Construction equipment telematics. *J. Constr. Eng. Manag.* **137**(10), 793–796 (2011). [https://doi.org/10.1061/\(ASCE\)CO.1943-7862.0000281](https://doi.org/10.1061/(ASCE)CO.1943-7862.0000281). Accessed 14 Mar 2023
- Luo, J., Chen, Y., Tang, K., Luo, J.: Remote monitoring information system and its applications based on the Internet of Things. In: 2009 International Conference on Future BioMedical Information Engineering (FBIE 2009), Sanya, China, 13–14 December 2009, pp. 482–485 (2009)
- Klingenberg, S.: Marktübersicht PKW-Telematik, Duale Hochschule Baden-Württemberg, Friedrichshafen (2017). [https://connect.eurotransport.de/wp-content/uploads/2017/01/Studienarbeit-PKW-Telematik\\_-DRUCKVERSION.pdf](https://connect.eurotransport.de/wp-content/uploads/2017/01/Studienarbeit-PKW-Telematik_-DRUCKVERSION.pdf). Accessed 16 Mar 2023



14. Deutsche Telekom AG, NB-IoT, LoRaWAN, Sigfox: ein aktueller Vergleich (2021). <https://iot.telekom.com/de/downloads/mobile-iot-netzwerk-vergleich-nb-iot-lorawan-sigfox>. Accessed 16 Mar 2023
15. Deutsche Telekom IoT GmbH. Mobile IoT Guide Comparison to alternative LPWA technologies (2023). <https://iot.telekom.com/en/downloads/mobile-iot-guide>. Accessed 27 Mar 2023
16. Guest, C.: Top 5 considerations when choosing IoT connectivity solutions (2022). <https://onomondo.com/resource-hub/top-5-considerations-when-choosing-iot-connectivity-solutions/>. Accessed 27 Mar 2023
17. Kainz, A., Bürger, M.: Die IoT-Kommunikation der Zukunft - LPWAN & LTE evolution. *Elektrotech. Inftech.* **133**(7), 348–350 (2016). <https://doi.org/10.1007/s00502-016-0432-8>. Accessed 16 Mar 2023
18. Rauch, J.: Home - Sigfox Germany GmbH. Sigfox Germany GmbH (2023). <https://sigfox.de/>. Accessed 27 Mar 2023
19. Prasanna. Zigbee Technology Advantages and Disadvantages. ZigBee Technology Architecture and Its Applications. *Aplus Topper* (2023). [https://www.aplustopper.com/zigbee-technology-advantages-and-disadvantages/#Disadvantages\\_of\\_Zigbee\\_technology](https://www.aplustopper.com/zigbee-technology-advantages-and-disadvantages/#Disadvantages_of_Zigbee_technology). Accessed 27 Mar 2023
20. grandcentrix GmbH. Connectivity Board. Universelles, CE-zertifiziertes Modul zur Vernetzung Ihrer Produkte (2023). <https://grandcentrix.net/de/products/connectivity-board/>. Accessed 23 Mar 2023
21. Pandya, K.H., Galiyawala, H.J.: A survey on QR codes: in context of research and application. *Int. J. Emerg. Technol. Adv. Eng.* **4**(3), 258–262 (2014)
22. Rouillard, J.: Contextual QR codes. In: *The Third International Multi-Conference on Computing in the Global Information Technology (ICCGI 2008)*, Athens, Greece, July–August 2008, pp. 50–55 (2008)
23. Lee, H.W., Harapanahalli, B.A., Nnaji, C., Kim, J., Gambatese, J.: Feasibility of using QR codes in highway construction document management. *Transp. Res. Rec.* **2672**(26), 114–123 (2018). <https://doi.org/10.1177/0361198118776133>. Accessed 16 Mar 2023
24. Chawla, V., Ha, D.S.: An overview of passive RFID. *IEEE Commun. Mag.* **45**(9), 11–17 (2007). <https://doi.org/10.1109/MCOM.2007.4342873>. Accessed 16 Mar 2023
25. Xie, L., Yin, Y., Vasilakos, A.V., Lu, S.: Managing RFID data: challenges, opportunities and solutions. *IEEE Commun. Surv. Tutor.* **16**(3), 1294–1311 (2014). <https://doi.org/10.1109/SURV.2014.022614.00143>. Third Quarter 2014. Accessed 16 Mar 2023
26. Finkenzeller, K.: *RFID-Handbuch: Grundlagen und praktische Anwendungen von Transpondern, kontaktlosen Chipkarten und NFC*. Carl Hanser Verlag GmbH Co KG (2015)
27. Weinstein, R.: RFID: a technical overview and its application to the enterprise. *IT Prof.* **7**(3), 27–33 (2005)
28. Yang, J., Poellabauer, C., Mitra, P., Neubecker, C.: Beyond beaconing: emerging applications and challenges of BLE (2019). <https://arxiv.org/pdf/1909.11737>. Accessed 16 Mar 2023
29. Jeon, K.E., She, J., Soonsawad, P., Ng, P.C.: BLE beacons for Internet of Things applications: survey, challenges, and opportunities. *IEEE Internet Things J.* **5**(2), 811–828 (2018). <https://doi.org/10.1109/jiot.2017.2788449>. Accessed 16 Mar 2023
30. Dian, F.J., Yousefi, A., Lim, S.: A practical study on Bluetooth Low Energy (BLE) throughput. In: *IEEE 9th Annual Information Technology, Electronics and Mobile Communication Conference (IEMCON)*, pp. 768–771. IEEE (2018)



31. Wang, S.-Y., Chang, J.-E., Fan, H., Sun, Y.-H.: Comparing the performance of NB-IoT, LTE Cat-M1, Sigfox, and LoRa for IoT end devices moving at high speeds in the air. *J. Sig. Process. Syst.* **94**(1), 81–99 (2022). <https://doi.org/10.1007/s11265-021-01660-4>. Accessed 16 Mar 2023
32. Mekki, K., Bajic, E., Chaxel, F., Meyer, F.: A comparative study of LPWAN technologies for large-scale IoT deployment. *ICT Express* **5**(1), 1–7 (2019). <https://doi.org/10.1016/j.ict.2017.12.005>. Accessed 23 Mar 2023
33. Liberg, O., Sundberg, M., Wang, E., Bergman, J., Sachs, J.: *Cellular Internet of Things: Technologies, Standards, and Performance*. Academic Press, Cambridge (2017)
34. Rosalina, A., Munadi, R., Fahmi, A.: Coexistence LTE with GSM and UMTS - performance analysis using SEAMCAT simulation. In: *IEEE International Conference on Communication, Networks and Satellite (COMNETSAT)*, Bandung, Indonesia, pp. 68–73 (2015). <https://doi.org/10.1109/COMNETSAT.2015.7434287>. Accessed 16 Mar 2023
35. Azari, M.M., Rosas, F., Pollin, S.: Cellular connectivity for UAVs: network modeling, performance analysis, and design guidelines. *IEEE Trans. Wirel. Commun.* **18**(7), 3366–3381 (2019)
36. Vodafone, IoT-Projekte anwendungsoptimiert umsetzen: NB-IoT oder LTE-M: Technologien für Ihre IoT-Projekte im Vergleich. <https://www.vodafone.de/business/loesungen/whitepaper-narrowband-iot-ltem/>. Accessed 16 Mar 2023
37. Mikulasek, M., et al.: NB-IoT vs LTE Cat M1: demystifying performance differences under varying radio conditions. In: *2022 14th International Congress on Ultra Modern Telecommunications and Control Systems and Workshops (ICUMT)*, Valencia, Spain, October 2022, pp. 133–138 (2022)
38. InHand Networks. LTE CAT 1 VS CAT M1: What are the differences?: Edge Routers. Cellular Routers & Gateways. IoT Solutions. 5G. InHand Networks (2023). <https://www.inhandnetworks.com/lte-cat-1-vs-cat-m1.html>. Accessed 16 Mar 2023
39. Li, S., Zhang, Y., Hernes, M.: Bluetooth low energy tree structure network: application report (2019). [https://www.ti.com/lit/an/swra648/swra648.pdf?ts=1679040627019&ref\\_url=https%253A%252F%252Fwww.google.com%252F](https://www.ti.com/lit/an/swra648/swra648.pdf?ts=1679040627019&ref_url=https%253A%252F%252Fwww.google.com%252F). Accessed 16 Mar 2023
40. McKinsey Global Institute. Reinventing construction through a productivity revolution (2023). <https://www.mckinsey.com/capabilities/operations/our-insights/reinventing-construction-through-a-productivity-revolution>. Accessed 27 Mar 2023



# Investigation of Data Transmission Between Construction Machines and Attachment Tools via OPC UA Technology

Kathrin Land<sup>1</sup>(✉), Birgit Vogel-Heuser<sup>1</sup>, Marius Krüger<sup>1</sup>, Jan-Kristof Chen<sup>1</sup>, and Johannes Fottner<sup>2</sup>

<sup>1</sup> Institute of Automation and Information Systems, School of Engineering and Design, Technical University of Munich, Munich, Germany

{kathrin.land, vogel-heuser, marius.krueger, jan.chen}@tum.de

<sup>2</sup> Chair of Materials Handling, Material Flow, Logistics, School of Engineering and Design, Technical University of Munich, Munich, Germany

j.fottner@tum.de

**Abstract.** Construction sites require improved information logistics in order to obtain an efficient overview of the construction machine and attachment tools available on the construction site as well as their maintenance states. To enable data transfer to the central back office, an information technology integration of the machine and its tools is necessary. OPC UA is considered a potential solution to connect the devices and gather the information required. In this paper, a communication architecture using OPC UA is proposed to connect construction machine and attachment tools on the construction site with the back office. To evaluate the runtime performance of the communication architecture proposed, an experimental setup, which covers the communication on construction sites, is designed to measure the transmission time and data loss of the communication considering different PLC cycle times and data sizes. This paper contributes an order of magnitude for the transmission time and data loss in dependence of the performance class and cycle time of hardware devices.

**Keywords:** Connected machines and networks · runtime investigation · OPC UA

## 1 Introduction

Various construction machines (e.g., hydraulic excavators) are used on construction sites. Depending on the application, they are equipped with one or more attachment tools (e.g., shovel types for digging or loading) during operation to meet the flexibility required on the construction site. This results in the challenge of managing the construction machine and their attachment tools efficiently and across several construction sites. On a large construction site with several processing steps, the overview of whether certain attachment tools are still needed on the construction site or their condition (e.g., wear, current activity) can be lost, so that an attachment tool that could already be used on another construction site is transported away much later than necessary or the need for maintenance

work is recognized too late [1]. According to the MIC 4.0 cluster [2], there is a lack of systematic management of construction machine and attachment tools on construction sites even though digital information is strongly required [3]. In order to implement automated management on the construction site and across several construction sites, the attachment tools as well as the construction machine need to be digitized and integrated into an Industrial Internet of Things (IIOT). Further, construction machines have to be able to adapt in a plug-and-play manner to its attachment tools and communicate with them during operation (e. g. to retrieve data on ground type from sensors mounted on the attachment tools). However, the attachment tools are provided by different manufacturers and thus use different platforms and implementations. To connect them all, a uniform and cross-platform interface for data exchange is necessary [2]. Therefore, the Open Platform Communications Unified Architecture (OPC UA) Standard is a promising platform- and manufacturer-independent communication architecture based on a sever-client model which provides a unified communication protocol from sensor to cloud. OPC UA is scalable and can be used on embedded devices like smart sensors as well as on industrial PCs with powerful multi-core processors [4]. OPC UA technology is already implemented in some applications on construction sites and mobile machines for data exchange. The main advantage of OPC UA is that a data model is already defined so that the exchanged data sets can easily be interpreted. However, this leads to a communication overhead and an increased workload of the OPC UA server and client devices. Especially, the workload on hardware devices is important for mobile machines because they are equipped with resource-limited embedded devices or PLCs. However, mobile machines are often upgraded with more powerful devices. Nevertheless, it must be investigated whether OPC UA technology is suitable for the widespread use in the construction domain.

In this paper, a OPC UA communication architecture is proposed to connect construction machines to its attachment tools and internal sensors as well as to the back office, which acts as central data server. The data transmission rate and data loss of OPC UA connections are measured and analyzed for the proposed setup with hardware devices for OPC UA server and client that have comparable performances as more powerful control units are coming onto the market for mobile working machines. Thus, this paper contributes an order of magnitude for the transmission time and data loss in dependence of the performance class and cycle time of hardware devices. The paper is structured as follows: In Sect. 2, the related work in the usage of OPC UA technology and analysis of communication technologies is presented. The concept for an OPC UA communication architecture on construction sites is discussed in Sect. 3. In Sect. 4, the measurement results of the transmission time and data loss are shown, followed by a discussion in Sect. 5. Section 6 summarizes the current work.

## 2 Related Works

In the following, the usage of OPC UA in the domain of mobile machines are discussed, followed by a literature overview of communication technology investigations. First approaches that analyze the suitability of OPC UA for mobile machine domain are addresses for agriculture use cases and remote machine access. Two exemplary

approaches are presented below. Oksanen et al. present a remote monitoring application and use OPC UA to access data of a harvester remotely [5]. They measured the data transmission latency and showed that latencies below 260 ms can be reached which fulfills the requirements from telemetry use case in agriculture. Seilonen et al. [6] present an OPC UA based server architecture for the communication with mobile machines. The architecture contains an aggregating OPC UA server to connect different devices or machines to information systems. They evaluate the proposed architecture in a use case from remote mobile machine monitoring and demonstrate the tentative feasibility [6]. The current work in analyzing communication architectures is conducted from the literature. Trunzer et al. [7] compare different communication technologies for data transfer within automated production systems and recommend a OPC UA Pub/sub communication model using MQTT-protocol to enable plug-and-play registration of OPC UA servers to clients, thus reducing manual configuration effort [7]. Hard-time constraints however are better achievable using OPC UA via TSN protocol [8].

The cycle time of a PLC has an influence on the transmission time of messages via OPC UA. Basically, the transmission time consists of three essential points: 1) Cycle time of the sender PLC, 2) Transmission time in the network and 3) Cycle time of the receiver PLC. Vogel-Heuser et al. [9] measured the latency times between sensor, PLC, and actuator (cf. Fig. 1), showing a total delay time of 18 ms from sensor to actuator. The measurement concept and timing delays are transferable to several participants in the network using OPC UA. Vázquez [10] measured the timing of data transmission between a single OPC UA client and a server, considering different PLC types and focusing on timing behavior depending on the number of request nodes. He focused on manufacturing systems thus not considering construction site requirements.

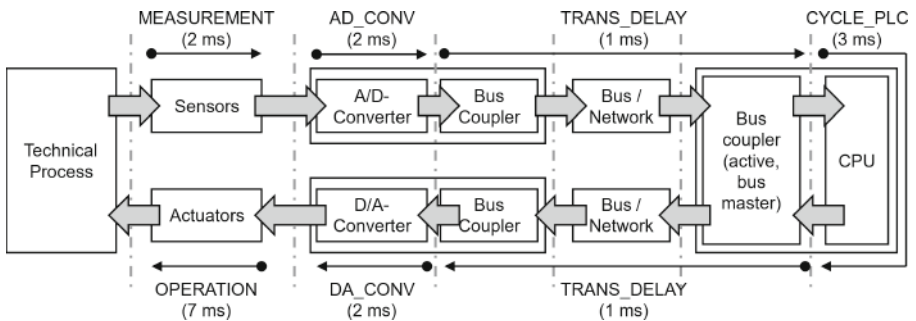

**Fig. 1.** Timing within the communication network (simplified from [9])

Considering the related work introduced above, an order of magnitude for the transmission time and data loss in dependence of the performance class and cycle time of hardware devices regarding a construction site use-case is missing. Thus, the following research question shall be addressed within this paper: *What is the impact of performance class and cycle time of hardware devices on the transmission time and data loss when using OPC UA technology for data transmission between construction machines, their attachment tools and a central back office?*

### 3 Concept for Inter-communication of Mobile Construction Machines and Their Attachment Tools Using OPC UA

This section introduces the concept for the communication architecture. The goal is to realize a robust and platform-independent communication between the construction machines and their attached tools as well as for their internal communication to various sensors. Therefore, OPC UA is used on the industrial PC (IPC) of the construction machine as standardized communication protocol. The attachment tools as well as internal sensors contain an OPC UA server each. They provide their respective data, for example their maintenance and usage state via the OPC UA server. The construction machine contains an OPC UA Client requesting data via the respective OPC UA servers (cf. Fig. 2). The data requested contains sensor information as well as special information regarding the control of the attached tool.

Upon connection, the attached tool autonomously registers at the construction machine in a plug-and-play manner and transmits its data to the machine. The construction machine collects and aggregates the data received and forwards it compact to the back office, as sending aggregated data via OPC UA saves time [10]. Therefore, the construction machine contains an OPC UA server, and the back office contains an OPC UA client to request the data from several construction machines. Construction machines on the construction site connect to the respective back office OPC UA server. The resulting architecture is used for the experimental setup (cf. Fig. 3) to conduct the evaluation of timing and data loss that occur during transmission using the construction machine IPC to forward information. As experimental use-case, data is transmitted from an attachment tool to the construction machine and from there to the back office. Thus, each OPC UA server sends its data actively and the clients receive the data respectively. The construction machine hereby incorporates both roles, OPC UA server and client thus receiving and then forwarding the data via OPC UA.

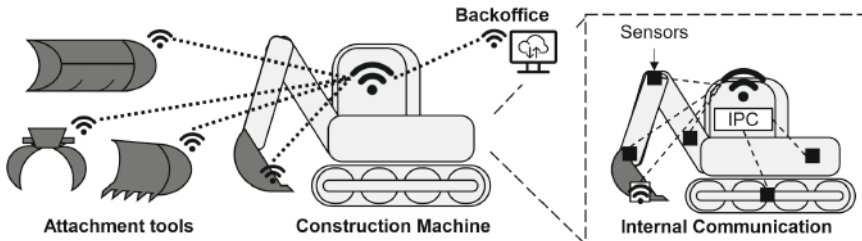

**Fig. 2.** Communication between back office, construction machine and its attachment tools and sensors (internal communication on right-hand side).

### 4 Timing and Data Loss Experiments

To investigate the runtime performance of the communication architecture proposed, the transmission time and data loss of the communication is evaluated considering different PLC cycle times and data sizes. In the following, the timing experiments conducted are

introduced. First, the experimental setup is described and second, the data recorded is presented.

#### 4.1 Experimental Design

The experimental hardware setup to conduct the timing measurement tests is depicted in Fig. 3. Construction machine control is usually realized by an embedded system with low memory space and cyclic processing of the software. To resemble an attachment tool, a Beckhoff CX2040 PLC is chosen for the experimental setup. In industrial practice, even less performant PLCs are used for attachment tools. For the construction machine and the back office, an industrial PC (IPC) with an Intel Atom Processor was selected in each case. IPCs are more powerful than PLCs and can handle tasks that PLCs cannot handle due to their lower capacity and cyclic behavior. In a second experiment, the IPC for the construction machine is replaced by a higher performing PC with an i7-4850HQ processor to evaluate the resulting time savings. All data transmissions are guided by routers and switches which are omitted in Fig. 3 for clarity.

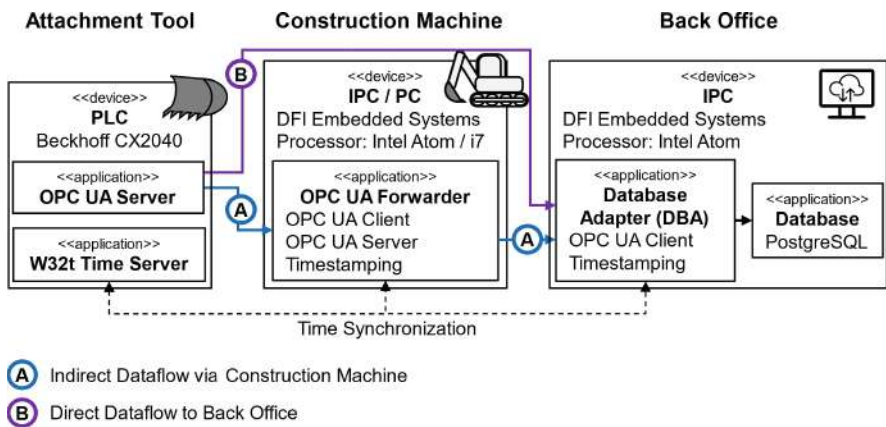

Fig. 3. Experimental hardware setup to conduct the timing measurement tests.

For the experiment, data is generated in a control program on the PLC. Two transmission scenarios are considered for comparison of the data transmission times: A) the generated data is transmitted from the attachment tool PLC to the construction machine which forwards the data to the back office and B) the data is transmitted directly from the PLC to the back office, where it is stored in a central database. To track the duration of the data transmissions between the components, the data are time-stamped at each arrival and departure from the respective participant. The data packages sent through the network are supplemented by a placeholder to be filled with the timestamps recorded as well as a header indicating the package number, which used in the IPC of the back office to detect data loss. Three different data packages are transmitted per PLC cycle in order to determine the data compressibility required to avoid transmission time overhead or data loss: 1) One numeric variable, leading to 238 Bytes, 2) 4 numeric and one

boolean variable, leading to 1183 Bytes and 3) 4 numeric, one boolean and one byte array variable, leading to a total of 2455 bytes. As each device has an internal clock, time synchronization is required to obtain matchable timestamps. Both IPCs communicate with the W32t time server of the PLC in regular intervals to synchronize their internal clocks with the PLC’s clock. As the cycle time of the PLC is assumed to affect the transmission time of messages via OPC UA, different PLC cycle times (10, 20, 30 ms) are regarded for comparison.

### 4.2 Measurement Results

First, the total transmission time between the creation of the data and its arrival at the database adapter (DBA) is measured for each transmission scenario, data package size and PLC cycle time. Second, the average data loss rate is determined based on the data packages that reached the DBA. The results recorded (cf. Fig. 4) are depicted with their mean value (dots) and their standard deviations (rectangles) scaled by a factor of 0.25 for clarity.

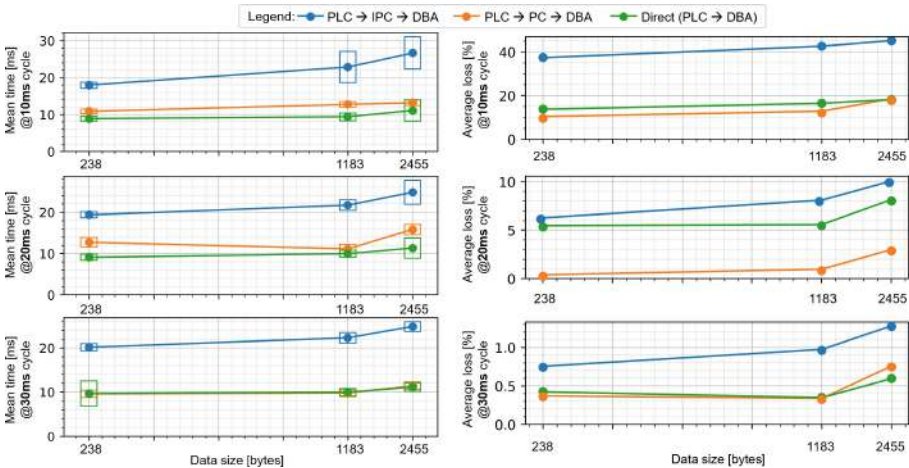

**Fig. 4. Transmission times (left) and average data loss (right) from PLC to DBA - via IPC (blue), via PC (orange) or direct (green) regarding three different PLC cycle times (top: 10 ms, middle: 20 ms, bottom: 30 ms)**

## 5 Results Discussion

Comparing the two scenarios A and B, the transmission time via the construction machine IPC is larger than the direct transmission from PLC to the IPC of the back office. However, installing a higher performing PC instead of an IPC for the construction machine reduces both the transmission time and the data loss significantly. Comparing the measurements for the different cycle times, the mean transmission times are similar. Thus, the impact of



the cycle times on the overall transmission time is negligible. Further, the transmission times measured span a range from 10 ms to 30 ms which is similar in size to the PLC cycle times. Thus, the worst-case duration is in a similar range. Concluding, if the transmission times are within the range of the cycle time of the PLC, the transmission delay does not generate overhead.

On the other hand, data loss not only increases significantly with lower cycle times but also with rising amounts of data, as the OPC server drops more values before the processing cycle is over (cf. Right-hand side of Fig. 4). The main thread of the OPC UA server on the construction machine is interrupted due to new data arriving from the PLCs. Data loss due to interruption is more likely to happen in scenarios of short cycle times. The average data loss decreases with an increasing cycle time from 40% for 10 ms cycle time to 1.5% for 30 ms cycle time for the biggest data size considered. Thus, a minimum cycle time of 30 ms is recommended to minimize the data loss expected. As real machines usually operate with cycle times between 20 and 100 ms, the average data loss for cycle times higher than 30 ms is expected to be equally small and thus negligible, especially if higher performant hardware devices are assumed to be used in the future.

## 6 Conclusion

Construction sites require improved information logistics in order to obtain an efficient overview of the construction machines and attachment tools available on the construction site as well as their maintenance states. Fast data transmission enables construction machine operators to react quickly to e. g. wear and tear, or for the attachment to provide feedback on current sensor values relevant during operation (e. g. ground type). To enable data transfer to the central back office or between the machine and its tools, an information technology integration of the machine and its tools is necessary. OPC UA is considered a potential solution to connect the devices and gather the information required. However, connection to the back office can be instable depending on the location and environmental conditions of the construction site and if each client transmits its data separately to the back office, this can become a flood of information that takes up additional time at the back office.

In this paper, an order of magnitude for the transmission time and data loss in dependence of the performance class and cycle time of hardware devices is given. Therefore, a data transmission architecture between attachment tools, construction machine, and back office using OPC UA was proposed and evaluated with timing and data loss measurements. The architecture proposes a forwarding device in the construction machine to gather and buffer temporal data points of itself and its attachment tools and send them compact to the back office to prevent data loss due to an instable connection to the back office or information flood. The measurement results indicate the increase in transmission time with increasing size of the data packages transmitted as well as with the decreasing cycle time of the PLCs used on the respective attachment tools. However, the results indicate that given a cycle time of at least 30 ms for the PLCs of the smart sensors or attachment tools, the transmission time as well as the data loss become negligible small in comparison to the cycle time. The time delay and data loss due to



the forwarding concept in comparison to a direct transmission (given a stable connection) can be reduced to a similar level by the use of a high-performant hardware for the forwarding device in the construction machine.

**Acknowledgement.** The research results presented in this paper were developed in the IGF-project 22511 BG of the research association Bundesvereinigung Logistik (BVL) e.V. The project was funded by the AiF as part of the program for the promotion of industrial joint research (IGF) by the Federal Ministry for Economic Affairs and Energy.

## References

1. Fischer, A., Bedrikow, A.B., Kessler, S., Fottner, J.: Equipment data-based activity recognition of construction machinery. In: IEEE ICE/ITMC (2021)
2. Soßdorf, D.: MiC 4.0 Basics und Arbeitskreise. MiC 4.0 - Machines in Construction 4.0 (Arbeitsgemeinschaft). <https://mic40.vdma.org/viewer/-/v2article/render/45913344>. Accessed 14 Apr 2023
3. Günthner, W., Borrmann, A.: Digitale Baustelle- innovativer Planen, effizienter Ausführen: Werkzeuge und Methoden für das Bauen im 21. Jahrhundert. Springer, Heidelberg (2011). <https://doi.org/10.1007/978-3-642-16486-6>
4. Burke, T.J.: OPC unified architecture interoperability for industrie 4.0 and the Internet of Things 4.0 industrie IoT M2M. Technical report, OPC Foundation, p. 7. (2016). [www.opcfoundation.org](http://www.opcfoundation.org)
5. Oksanen, T., Linkolehto, R., Seilonen, I.: Adapting an industrial automation protocol to remote monitoring of mobile agricultural machinery: a combine harvester with IoT. IFAC-PapersOnLine **49**(16), 127–131 (2016)
6. Seilonen, I., Tuovinen, T., Elovaara, J., Tuomi, I., Oksanen, T.: Aggregating OPC UA servers for monitoring manufacturing systems and mobile work machines. In: IEEE ETFA, pp. 1–4 (2016)
7. Trunzer, E., Schilling, T., Müller, M., Vogel-Heuser, B.: Comparison of communication technologies for industrial middlewares and DDS-based realization. In: IFAC World Congress, pp. 11082–11089 (2020)
8. Pfrommer, J., Ebner, A., Ravikumar, S., Karunakaran, B.: Open source OPC UA PubSub over TSN for realtime industrial communication. In: IEEE ETFA, pp. 1087–1090 (2018)
9. Vogel-Heuser, B., Feldmann, S., Werner, T., Diedrich, C.: Modeling network architecture and time behavior of Distributed Control Systems in industrial plant automation. In: IEEE IECON, pp. 2232–2237 (2011)
10. Vázquez, F.G.: Test platform for the performance evaluation of OPC-UA servers for fast data transfer between intelligent machine. In: INTELLI (2015)



# Activity Recognition for Attachments of Construction Machinery Using Decision Trees

Marc Theobald<sup>(✉)</sup>  and Felix Top 

Vemcon GmbH, Süskindstr. 4, 81929 Munich, Germany  
m.theobald@vemcon.de

**Abstract.** Activity recognition in construction helps operators and managers by providing information about current and past use of machines and tools. At the same time, excavator attachments enable excavators to perform other physical tasks in addition to earthmoving like screening or compacting. This work addresses the prototype of an activity recognition for excavator attachments independent of the carrier machine. Activity recognition was implemented for buckets, compactors, grabs, and screeners. The recognition is based on acceleration data and angular velocities collected by an inertial measurement unit on the attachment. Decision trees are used for classification. The activity classes “Operation”, “Transport”, and “Rest” were defined as target classes for the activity recognition. The decision trees achieved accuracies comparable to other machine learning algorithms. The results indicate that activity recognition of attachments should distinguish between different attachment classes like buckets and crabs.

**Keywords:** Activity Recognition · Construction Equipment · Decision trees · Excavator attachments · Classification in supervised machine learning

## 1 Introduction

### 1.1 Motivation

Monitoring and analysis is an important step towards the digitalization of the construction site. Activity recognition benefits this step by providing important information about current and past use of machinery and tools. Distinguishing between different activities (e.g., operation, transport) can be used among other things, to schedule maintenance appointments or rent equipment based on operating hours. At the same time excavators are used to carry increasingly complex attachments. With these, an excavator can take over strenuous and dangerous work that was previously performed manually by construction workers. Due to their interchangeability, the operating hours of these attachments differ from those of the carrier machines. Recognizing attachment activity in real time can help the operator to use these costly devices more efficiently. Machine learning is used for activity recognition to cope with the complex environment of the construction site. Among the popular algorithms in machine learning, this study focuses on decision trees. These algorithms can handle both numeric and nominal variables and have a model

that is easy to understand and at the same time requires little memory and computing power for evaluation [1, 2]. Decision trees are widely accepted in industry and science and are used in several similar works dealing with activity recognition for construction machines [3–7].

## 1.2 Related Work

Activity recognition for construction machinery can be divided into vision-based and sensor-based approaches [7]. Several authors' work supports sensor-based activity recognition. Bae et al. used the joystick movements of operators to determine the current activity of the excavator [8]. Fischer et al. used internal sensors of a rotary drilling rig to determine its current activity [9]. Many authors rely on inertial measurement units (IMUs) to collect a data basis for activity recognition. Mathur et al., Ahn et al. and Kim et al. used the IMU of a smartphone mounted in an excavator cabin to collect data for activity recognition [3, 5, 6]. Akhavian and Behzadan followed a similar approach with a front-end loader [4]. Rashid and Louis improved the accuracy of an activity recognition by mounting three IMUs on bucket, stick and boom of an excavator [7]. Among these IMU based approaches, Ahn et al. only relied on acceleration data for classification while the other authors relied on angle velocity data as well [3]. All approaches compared different supervised machine learning algorithms for activity recognition. Among others, K-nearest neighbor (KNN), linear regression (LR), NaiveBayes (NB), support vector machines (SVM), random forest algorithm (RF), multilayer perceptron (MLP) and decision trees (DTs) were considered. Rashid and Louis as well as Akhavian and Behzadan reached the highest classification accuracy using MLP, while for Fischer SVM performed best [4, 7, 9]. Kim et al. and Mathur et al. determined RF as a superior algorithm and Ahn et al. reached best results using DT [3, 5, 6].

## 1.3 Relevance and Objective

All previously introduced sources focus on construction machinery and mostly on digging tasks. However, excavator attachments can be used for a wider range of tasks such as screening or compacting, which have not been considered previously. They can be assigned to multiple excavators and one excavator can use multiple attachments. Therefore, excavator attachments require a separate activity recognition to monitor them efficiently and independent of the carrier machine. In turn, this allows to provide operator and owner with real time data about the current and past activity of the equipment.

This paper investigates the possibilities of activity recognition for excavator attachments using DTs. Activity classes, input data and data processing are optimized for excavator attachments in particular. The prototype of such an activity recognition is implemented and evaluated. The performance differences between four classes of attachments are investigated and the accuracies are compared with other supervised learning algorithms. As a result, for the first time we present an activity recognition for excavator attachments which is independent from the carrier machine.

## 2 Methodology

The first step of this work was to select the classes of excavator attachments to be considered in the activity recognition. Then activity classes, the later target classes of the activity recognition, were defined for these attachments. For each of these activity classes, field data consisting of acceleration and angular velocity were collected within all attachment classes. These datasets were divided into training and validation data. After further data preparation, these data serve as input values of the DTs.

### 2.1 Class Definition

Excavator movements depend on the attachment that is used. Therefore we propose separate DTs for each attachment class. One goal of this work was to focus on the most common attachment classes. To find these classes, the attachment class of more than 500 excavator attachments in Germany were evaluated. All of them were chosen randomly from a large customer database. Similar attachment sub-classes, such as clamshell grabs and sorting grabs, were grouped into general classes such as grabs. To simplify data collection, demolition tools such as crushers and breakers were not considered. The four most common attachment classes in this evaluation were buckets, grabs, compactors and screeners. Ultimately this paper focuses on the four attachment classes depicted in Fig. 1. A fifth general class, combining data of all four attachment classes, is introduced to evaluate the distinction between classes.

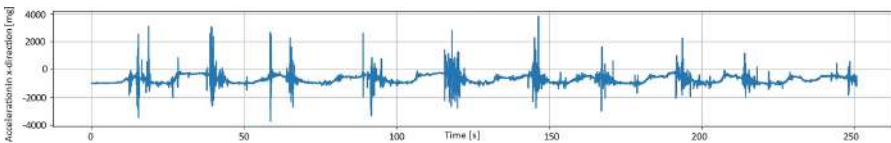

**Fig. 1.** Excavator attachments used in this work. From left to right: Bucket, compactor, grab and screener. Pictures taken by Marc Theobald.

When defining the activity classes, the level of detail (LoD) must be specified. A high LoD means a high number of activity classes and a large added value when classified correctly. However, a high LoD decreases the accuracy of activity recognition [4, 7]. According to [8], the operators of construction machinery are primarily interested in operating hours to assess their efficiency. Hence, the three activity classes “Operation”, “Transport”, and “Rest” were defined. “Operation” includes all activities in which any hydraulic components of the attachment are active, or the attachment is used by moving the excavator arm. “Transport” includes all changes in the location of the attachment by moving the excavator or separately transporting the attachment on trucks. “Rest” includes all activities where the attachment is not moved or used.

## 2.2 Data Collection

For data acquisition, IMUs were attached to the attachment bracket in an arbitrary orientation. These IMUs collect acceleration, angular velocity, temperature and GNSS data. The activity recognition of this work is based on acceleration data and angular velocities that can be measured with accuracies of 20 mg and 1 dps by the IMUs. Rashid and Louis point out that acceleration data at the attachment is more valuable for activity detection than acceleration data at other positions on the excavator arm [7]. Similar works have chosen measuring frequencies in the range of 100 Hz. Since attachments usually do not have an active electric power supply the IMUs capturing the input data for the activity recognition need to be battery powered. A lower measurement frequency helps to keep the electric power consumption of these IMUs low. Therefore acceleration values and angular velocities were collected in three axes each with a measuring frequency of 26 Hz as input values for the activity recognition.



**Fig. 2.** Plot of acceleration samples in x-direction during digging task. The measurement was taken using a bucket and was classified as “Operation”.

It is assumed that acceleration values and angular velocities of the attachment classes differ negligibly during “Transport” and “Rest”. This reduces the effort in data collection for these two activity classes since it does not have to be performed for each attachment class. Each measurement comprises one activity and lasts approximately five minutes. The plot of an example measurement can be seen in Fig. 2. Between the measurements, application scenarios of the attachments were varied. For example, a bucket was used for digging and leveling. Furthermore, sensor orientation and processed materials were altered.

The collected data include 49 measurements with a total duration of 337 min. 21 different attachments on 11 different hydraulic excavators were considered. The transport data was collected on 3 different carrier vehicles. In total, the vehicles were operated by 8 different drivers. The data was collected on five different test sites, construction sites and roads in southern Germany. Depending on the attachment class between 70 and 80% of the samples were used for training the model. The exact percentage of samples varies between attachment classes because measurements were only fully assigned to training or validation data. The remaining samples were used for validation purposes. An overview of the collected data can be seen in Fig. 3.

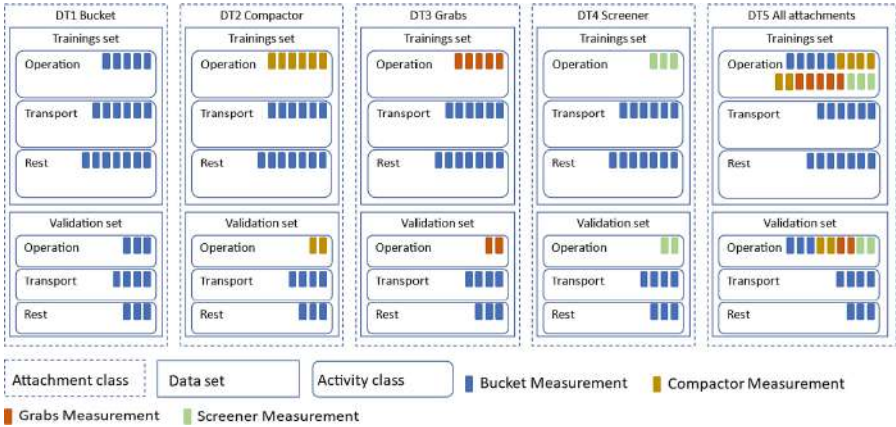

Fig. 3. Overview of collected data

### 2.3 Data Preparation

The measurement data of the IMUs consist of three acceleration values and three angular velocity values. These six values were preprocessed in three steps before they are used in the DTs for classification. The steps are summarized in Fig. 4. Data preparation was performed according to the sensor manufacturer's specification.

**Lowpass.** Unlike smartphones, most IMUs do not have integrated noise reduction [7]. Therefore, a low-pass filter is used to suppress noise in the data. The chosen Butterworth filter is particularly suitable for noise reduction of motion data. It requires little computing power and hardly distorts the signal in the passband [10].

**Norm Calculation.** The IMU values contain acceleration and angular velocity in three axes. Each sample therefore consists of six values. This information can only be interpreted if the IMU direction is known. Since the orientation of the IMUs is not always comparable, the norm of acceleration and angular velocity is calculated. This information loss is accepted to avoid inaccuracies due to different IMU orientations.

**Feature Calculation.** After norm calculation, each sample consists of acceleration norm and angular velocity norm. A classification on this two-value basis could produce a classification result, but it would be inaccurate due to the small database. To provide a larger database, the literature groups samples in evaluation windows [3–5, 7]. Within these windows, statistical quantities, such as mean and variance, can be calculated. These so-called features represent the pattern of the signal in the respective time window and are suitable as classification input data [7]. A window length of 104 samples is used, because shorter window lengths showed negative effects on classification accuracy. The amount of 104 samples per evaluation window together with a measurement frequency of 26 Hz leads to a duration of four seconds for each evaluation window. This results in one classification every four seconds. In literature, time-domain and frequency-domain features are used for classification [3–6]. Due to the computationally intensive transformation into the frequency domain, features in the time domain are better suited for

real-time applications [11]. In this work, eight features are computed for each of the two normalized values in each evaluation window. The features are mean, variance, sum, peak to peak amplitude, zero crossing, number of peaks, minimum and maximum. The eight features for acceleration values and angular velocities result in a total of 16 possible features as input values of the DTs. To avoid overfitting, correlation-based feature selection (CFS) was used [4]. The selected features are peak to peak amplitude, zero crossing, number of peaks and minimum of acceleration values and zero crossing and maximum of angular velocities.

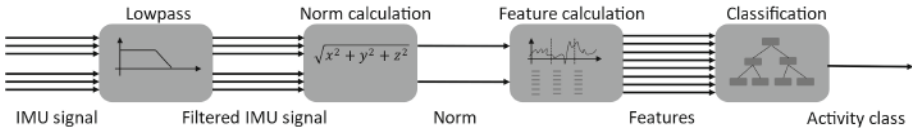

**Fig. 4.** Data preparation block diagram. The number of arrows corresponds to the number of data values passed per sample.

## 2.4 Classification Model

The classification is done by DTs. To generate them, the J48 algorithm was used. It is based on the C4.5 DT design, a powerful and widespread algorithm [12]. To improve the classification, the training data of all DTs are weighted so that the shares of the three activity classes are evenly distributed. Within the J48 algorithm two parameters were varied. The minimum number of objects per leaf determines how far the DTs grow in the growing phase [2]. The confidence factor influences how far the DTs are shortened in the pruning phase. Both values were optimized for the individual DTs based on cross-validation accuracy. The parameters are summarized in Table 1.

**Table 1.** Decision tree parameters

Parameter	Decision Tree				
	Bucket	Compactor	Grabs	Screener	All attachments
Confidence factor	0.250	0.025	0.250	0.790	0.079
Minimum number of objects	4	4	5	4	4

## 3 Results

### 3.1 Model Accuracy

During data preparation, process accuracy was used to compare process parameters like evaluation window length. Accuracy is defined as percentage of correctly classified activity classes. It was determined using the cross-validation procedure and is based

solely on the training set. Since the classification algorithms were trained with these data, the accuracies used to compare algorithm parameters have limited validity. Validation data are used in this chapter for the concluding evaluation of the activity recognition. These validation data are independent of the training data but are prepared and classified by the same algorithm.

The diagonal of Table 2 shows the accuracies of the five DTs, based on the validation data set. All of them achieve an accuracy above 89%. Except for the screener-tree, all of them even achieve an accuracy above 92%.

**Table 2.** Accuracy matrix between attachment classes based on validation sets.

		Validation Set				
		Bucket	Compactor	Grabs	Screener	All attachments
Decision tree	Bucket	97.2%	94.6%	61.2%	90.5%	93.2%
	Compactor	90.8%	97.2%	78.2%	92.9%	90.0%
	Grabs	97.2%	95.4%	92.4%	84.2%	92.8%
	Screener	94.8%	97.1%	77.0%	89.2%	92.4%
	All Attachments	96.0%	96.5%	75.9%	91.0%	95.0%

### 3.2 Comparison Among Attachment Classes

To compare accuracy among the attachment classes. The five DTs are evaluated with the validation data of the five attachment classes. Table 2 shows the accuracy matrix of the five DTs evaluated on the five validation sets. The rows of the table correspond to the five DTs, and the columns correspond to the validation data of the five DTs. Each DT is judged on how well it can classify the attachment validation set for which it was trained. This data can be seen in the diagonal of Table 2. In order to detect synergies between the DTs of the different attachments, the trees are additionally evaluated with the validation sets of the other attachments. These accuracy values can be found in the non-diagonal elements of Table 2. The evaluation with validation data of other attachment classes was performed to determine whether the distinction between attachment classes is necessary, or whether the classification of the validation data of one or more classes can be performed by other DTs. The fifth DT was designed for this purpose, using training data from all four attachment classes.

As expected, the highest accuracy on the respective validation data should be achieved by the DT created using the associated training data. It is conceivable that data from some attachment classes may be easier to classify than data from other classes. For example, the movement of screeners during operation are harder to distinguish from the movements during transport than for the grabs class. Thus, the diagonal is expected to contain the highest percentage value of the column, but not necessarily the highest percentage value of the row. Since the fifth DT was trained with data from all four attachments, it is expected to classify the validation set second best. Therefore the last row is expected to contain the second highest accuracy value of the first four columns.



Table 2 confirms these expectations only partially. Here, the DT created with the associated training data achieves the highest accuracy on four of five datasets (bucket, compactor, grabs and all attachments). Only for the validation data of the screener class the three DTs reach higher accuracies (bucket, compactor and all attachments). The DT designed for all attachment classes reaches the second highest accuracy value only in the fourth column (Screener validation set). Also, the highest row sum is not achieved by the tree designed for all attachments, but by the grabs tree.

The DT for all attachments does not meet the expectations placed on it. It achieves accuracies with three of the four other validation sets that are only a few percentage points below the value of the associated tree. For the attachment classes bucket, compactor and screener, classification by a common DT is thus possible. For the grabs class, it only achieves an accuracy of 76%, which is significantly below the accuracy of the associated DT. The reason for this remains unclear.

### 3.3 Comparison to Other Machine Learning Algorithms

Our work focuses on DTs as classification algorithms for activity recognition on attachments. DTs were chosen primarily because of the low computational power required to evaluate the model. Other factors include small model size and ease of understanding. However, in similar works, different machine learning algorithms were compared, some of which performed better than DTs [3–7]. Rashid and Louis evaluated a three-class problem and used acceleration data collected on the excavator arm [7]. SVM and KNN achieved similar accuracies as the bucket DT in this work while DT performed significantly worse for them.

Figure 5 shows the comparison of DTs with other algorithms performed in this work. The performance of the classification algorithms is evaluated by the accuracy on the validation set. The data preparation optimized for DTs was used.

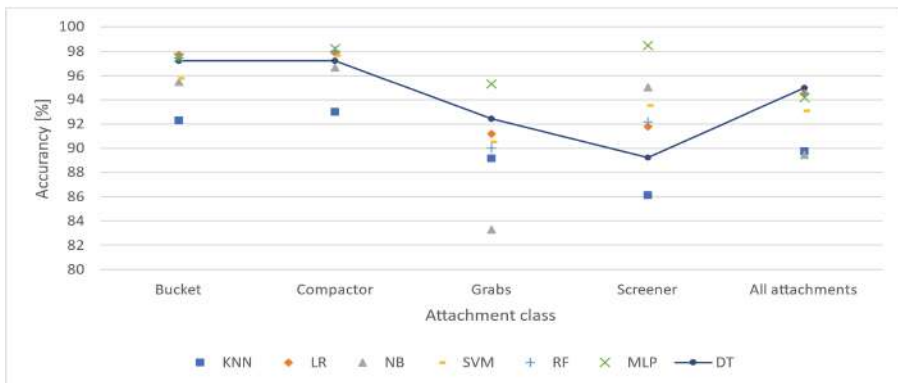

**Fig. 5.** Comparison with other machine learning algorithms. Considered algorithms are: K-nearest neighbor (KNN), linear regression (LR), NaiveBayes (NB), support vector machines (SVM), random forest algorithm (RF), multilayer perceptron (MLP) and decision trees (DT).

Almost all algorithms achieved higher accuracies on the first two validation sets than on the third and fourth. In three out of five cases, MLP achieves the highest accuracy. It also achieves the highest accuracy average of 96.8%. Other high averages are achieved by LR with 94.6%, SVM with 94.1% and the Random Forest algorithm with 94.4%. The results of DTs with 94.2% are also in this accuracy range. The remaining algorithms achieve average accuracies of less than 92%. Compared to the other six algorithms, DTs only performs remarkably poor with the screener validation set. In the case of the other validation sets, the accuracy achieved with the DTs is always less than 3% lower than that of the MLP.

## **4 Discussion and Conclusion**

### **4.1 Conclusion**

The aim of this work was to implement a prototype of an activity recognition system using decision trees. This prototype should be able to determine the activity of an attachment for construction machines based on acceleration data and angular velocities.

This goal was achieved. This work represents a contribution to activity recognition on construction machinery. It focusses especially on excavator attachments. We showed that activity recognition on attachments of construction machines by DTs is possible. The proposed activity recognition detects three activity classes on the four attachment classes bucket, compactor, grabs and all attachments with an accuracy of over 89%. The bucket class achieves the best results. Since other works have only classified earthworks only the bucket class can be compared. However, this attachment class achieves accuracies that are comparable to or better than the literature values [3, 5–7].

### **4.2 Limitation**

Various factors limit this work. Only four attachment classes were considered. To be able to make a holistic statement about attachments, further attachment classes should be considered, such as demolition equipment. However, as there exists no previous experience with activity recognition for attachments of construction machinery, this work is a valuable first step. In addition, only three activity classes were defined as target classes for activity recognition. It can be assumed that the classification accuracy decreases with increasing number of classes. This means that for future research, we recommend using a higher amount of activity classes to increase the accuracy differences between machine learning algorithms. Furthermore, different machine learning algorithms were compared based on a data preparation which was designed for DTs. In future investigations, the implementation of a real time activity recognition system on attachments should be included.

### **4.3 Outlook**

The Evaluation of the DT created for all attachment classes shows that it achieves good results with the three classes bucket, compactor, and screener, but insufficient accuracy





with the grabs class. This indicates that activity recognition of attachments should distinguish between different attachment classes. Nevertheless, the three previously mentioned classes can be combined. Synergies between these and other attachment classes should be investigated within further research. A comparison with other machine learning algorithms confirms that DTs achieve comparable accuracies in activity recognition. Only neural networks achieved higher accuracies on four of the five validation datasets. A more complex classification problem with more activity classes may highlight differences between the algorithms in the future.

## References

1. Jadhav, S.D., Channe, H.P.: Comparative study of K-NN, Naïve Bayes and decision tree classification techniques. *Int. J. Sci. Res. (IJSR)* **5**(1), 1842–1845 (2016)
2. Rokach, L., Maimon, O.: Top-down induction of decision trees classifiers – a survey. *IEEE Trans. Syst. Man Cybern.* **35**(4), 476–487 (2005)
3. Ahn, C.R., Lee, S.H., Peña-Mora, F.: Application of low-cost accelerometers for measuring the operational efficiency of a construction equipment fleet. *J. Comput. Civ. Eng.* **29**(2) (2015)
4. Akhavian, R., Behzadan, A.H.: Construction equipment activity recognition for simulation input modeling using mobile sensors and machine learning classifiers. *Adv. Eng. Inform.* **29**(4), 867–877 (2015)
5. Kim, H., Ahn, C.R., Engelhaupt, D., Lee, S.H.: Application of dynamic time warping to the recognition of mixed equipment activities in cycle time measurement. *Autom. Constr.* **87**(1), 225–234 (2018)
6. Mathur, N., Aria, S.S., Adams, T., Ahn, C.R., Lee, S.: Automated cycle time measurement and analysis of excavator’s loading operation using smart phone-embedded IMU sensors. In: William, J.B., Simone, P. (eds.) *Proceedings of the 2015 International Workshop on Computing in Civil Engineering*, Austin, pp. 215–222. American Society of Civil Engineers (ASCE) (2015)
7. Rashid, K.M., Louis, L.J.: Automated activity identification for construction equipment using motion data from articulated members. *Front. Built Environ.* **5**(1), 144 (2020)
8. Bae, J., Kim, K., Hong, D.: Automatic identification of excavator activities using joystick signals. *Int. J. Precis. Eng. Manuf.* **20**(12), 2101–2107 (2019). <https://doi.org/10.1007/s12541-019-00219-5>
9. Fischer, A., Liang, M., Orschlet, V., Bi, H., Kessler, S., Fottner, J.: Detecting equipment activities by using machine learning algorithms. *IFAC-PapersOnLine* **54**(1), 799–804 (2021)
10. Pezzack, J.C., Norman, R.W., Winter, D.A.: An assessment of derivative determining techniques used for motion analysis. *J. Biomech.* **10**(5), 377–382 (1977)
11. Maurer, U., Smailagic, A., Siewiorek, D.P., Deisher, M.: Activity recognition and monitoring using multiple sensors on different body positions. In: Wyatt, J. (ed.) *International Workshop on Wearable and Implantable Body Sensor Networks (BSN 2006)*, Cambridge (2006)
12. Hssina, B., Merbouha, A., Ezzikouri, H., Erritali, M.: A comparative study of decision tree ID3 and C4.5. *Int. J. Adv. Comput. Sci. Appl.* **4**(2), 13–19 (2014)



# How is the Profession of Excavator Operator Changing? The Demands of Digitalization and Automation of Construction Machinery from the Operator's Point of View

Martin Starke<sup>1</sup>  , Volker Waurich<sup>1</sup> , Marcel Schweder<sup>2</sup> ,  
Manuela Niethammer<sup>2</sup>, and Frank Will<sup>1</sup> 

<sup>1</sup> Chair of Construction Machinery, Technische Universität Dresden, Dresden, Germany  
martin.starke@tu-dresden.de

<sup>2</sup> Chair of Construction, Wood and Paint Technology and Interior Design/Vocational Didactics,  
Technische Universität Dresden, Dresden, Germany

**Abstract.** New technologies and digital solutions are currently rapidly entering the construction machinery sector. These include (partial) automation solutions for machines and the implementation of the first autonomous construction machines, which no longer require machine operators. The first of these can help relieve the personnel shortage in the future, but qualified skilled workers will still be needed to operate the construction machines. The qualification requirements will increase massively due to the increasing complexity of machine technology and the use of new technologies. Efficient and, above all, safe handling of the new machines and construction processes will be achieved not only by integrating new technologies, functions and machine types into the training and qualification content, but also by adapting the content of these training and qualification programs to ensure a high level of acceptance among operators.

This publication deals with the changes that operators are facing as a result of the digitalization of their occupation and analyzes the resulting challenges for the training and further education of machine operators on the basis of an exemplary activity.

**Keywords:** training · construction machines · interactive simulator

## 1 Introduction

As an essential element on the construction site, construction machinery significantly determines the efficiency and effectiveness of construction work. Between the increasing requirements of the construction industry (user side) and new technological offers of the machine and component manufacturers, constantly improved or newly developed machines are brought to the market. In the course of advancing digitalization, new types of systems, components, solutions and approaches are also entering the construction machinery sector and opening up forward-looking development potential. Digitization and the connectivity of construction machinery and construction sites are bringing

together the construction industry, telecommunications and the machinery. The establishment of “smart” products and services is a central field of action for the development of innovative business areas and the exploitation of efficiency potential in the technology leadership around Industry 4.0 [1]. In construction practice, the implementation of this claim has accelerated significantly in recent years. This publication deals with the digitization of work in the construction machinery sector. As a result, the digital content in the construction machinery sector will be highlighted and the resulting content for the job description of a construction machine operator discussed.

## 2 State of the Art

When considering new technologies for construction machinery, it is important to take into account the various subsectors that have either been modernized by alternative solutions or have become necessary by the increasing technological demands placed on machinery and processes [2].

These areas include the sensor equipment of the machines. Sensors are used to detect the position of the machine and the work equipment, to recognize people and objects in the machine environment, to record the machine status and to monitor the work process. Another area is the communication between machines (M2M) and within a system (e.g. fleet management system). In this area in particular, new fields of application are being created or have already been created through the use of new technologies, which will permanently change the operation of the machine and the execution of the construction profession. One example is a telematics system that processes and stores machine data and makes it available for retrieval. This data is used to enable applications such as condition monitoring, communication with attachments tools or the above-mentioned fleet management system. Drive technology is a subsector in which the use of new technologies has been particularly dynamic in recent years or is currently being developed. In this context, manufacturers are focusing on electrically driven construction machinery in order to meet future regulatory requirements. These changes generate completely new demands for the operators in terms of the start-up, maintenance and operation of the machine. Another issue is the human machine interface. Here, both the various machine manufacturers and the system developers are constantly coming up with new service and work place concepts. In particular, XR applications enable the operator to interact with the machine or process in new ways. The automation of the entire machine or only of individual activities is another area that has massively changed and will change machine operation. In the future, the operator will no longer carry out the process himself, but rather monitor it, whether on the machine or in a control station. This overview is deliberately very broad in order to illustrate that the digitization of construction machinery is very complex and that the changes that will result for employees will be just as complex. These issues can also be observed in other industries, such as agricultural technology [3] and many others. In [4] for example, selected occupations are analyzed in this context. When analyzing the challenges that digitalization causes for operators and, further on, for training requirements, it is useful to analyze individual problem situations [5]. For this reason, the following section examines an exemplary activity in order to show which requirements arise for the operators and, in the next step, also for training and further education.

### 3 Analysis of the Technological Transformation

This section uses the example of an earthwork building (e.g. digging a trench) to show the developments in the construction machinery sector and, based on the state of the art, to analyze the changes of new technologies for the work contents. The individual activities required to build the structure are analyzed and their implementation is shown in 4 technological expansion stages. For this purpose, the contents of the construction equipment training, technologies available on the market and current trends are used as a basis for the elaboration of the technological transformation. Methodologically, this content was developed in a multi-stage process based on [6]. This included a literature review to determine the current state of the art and the initial identification of new technologies as well as expert interviews and expert workshops with the instructors of training centers.

Depending on the size of the executing company or the construction site, the individual work steps can be implemented by different entities. But even if, for example, the operator does not always take care of surveying the building, the necessary knowledge must be available. In the framework curriculum for vocational training to become a construction equipment operator [7], one item of the skills to be learned is “handling surveying equipment.”

This includes:

- Handling surveying equipment, especially angle prism, leveling instrument and laser
- Align straight lines, measure lengths, and transfer and measure heights
- Setting up string and sighting devices and creating and checking right angles
- Measure components according to direction, position and height
- Stake out longitudinal and transverse profiles

Particularly for the “construction of excavations and trenches”, a transformation in the work process can be expected or already observed through the use of digital technology. This should be taken into account in the training content. With the introduction of digital terrain models, these tasks can be transferred into the automated machine in the future. For this purpose, the machine needs a planning basis consisting of the digital model of the construction site and the structure to be built. The additional work required includes copying the models into the excavator control system and checking for plausibility, i.e. whether the data shown on the display actually correspond to the structure to be built by the machine. Depending on which system is used, it may also be necessary to calibrate the working equipment at a reference point. In the following, 4 time-dependent technology levels are taken into account for the execution of the job considered here, and the associated activities of the operator are given. These start in the past, i.e., with a conventional machine and end in the future with the automated machine with environment detection. The technology levels focus on all relevant areas starting from the machine via the work process as peripheral activities, such as the building surveying.

#### 3.1 Level 1 Past/Present

The trench is constructed with a hydraulic-mechanical pilot-operated excavator. In advance, the terrain was surveyed and a site plan and an allowance were prepared.

Using a total station, GNSS receiver or rotating laser, the surveyor determines the necessary coordinate and measurement points and documents this. Based on this, the planning office draws up the necessary construction plans. For the actual process of digging, the following activities result for the operator:

- Reading and understanding the construction plan (paper)
- Setting up the construction site and transferring the construction plan to the terrain
  - Operating surveying equipment (angle prism, level and laser)
- Operation of the excavator with joysticks
  - Knowledge of actuator function, tool selection
  - Knowledge about hydraulic system, connection joystick deflection-machine behavior, knowledge about correct process sequence
- Control of the structure/measurement of the trench
  - Operation of surveying equipment (angle prism, leveling instrument and laser)

### 3.2 Level 2 Present

Currently systems are offered that visualize the work progress for the operator. The position of the work equipment is detected by sensors and shown on a display in the operator's cab. For this purpose, the terrain surface is defined as the starting position with the touching of the work equipment (driving to reference point). The target depth is set by the operator. By displaying the current position, the operator is supported in reaching the target depth with greater accuracy and more quickly. The activities to be performed by the operator are not substituted by this system. Rather, additional activities become necessary:

- Handling of the system interface
  - Define reference height terrain
  - Define reference depth
- Reading and understanding the digital display
  - Structure and function of the sensory equipment
  - Procedure in case of system errors, maintenance

### 3.3 Level 3 Present/Future

An extension of the system in Sect. 3.2 is offered in current machines as an assistance function to the extent of depth limitation or partial automation of individual actuators. In the latter case, the operator only has to perform the boom movement, and the bucket and boom cylinders are controlled in such a way that a defined height is maintained

at the bucket. These systems will gain further market acceptance and will be available on many machines in the near future. To achieve this, it is necessary for the valve pilot control of the hydraulic system to be electrohydraulically controlled. This function reduces the completion time of the building, increases safety and improves the quality of the structure. Additional operations are not necessary in comparison with the above mentioned ones. The definition of the position of the working equipment is also realized in these systems by moving to a reference point, which must be performed additionally. Another possibility is shown in Fig. 1 using a laser receiver.

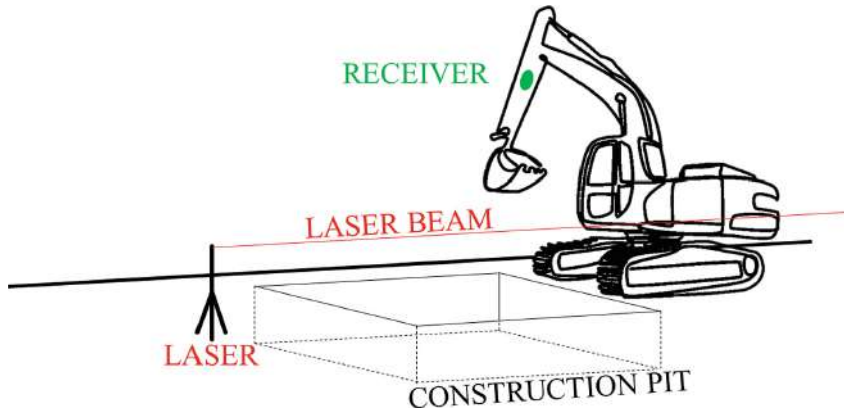

Fig. 1. Referencing the work equipment with laser receiver

### 3.4 Level 4 Future

In the future, the process will be (partially) automated. The terrain of the construction site will be surveyed at the start of planning and during the construction phase for documentation of the construction progress (e.g. by aerial flight with a drone). The resulting DTM and a 3D model of the trench are then transmitted to the control system as the basis for the task. This can be done either by the operator and a storage medium or via a cloud connection (telematics system). The operator sits down in the machine to start work and is shown all the necessary data on the control display. In the first step, the machine is located in the construction site environment (e.g. GNSS) in order to reach the target location of the building. Sensors of various types also determine the position of the work equipment. The process is fully or partially automated. Depending on the design, the operator only takes over a supervising activity or still has to specify individual joystick control signals. The activities to be performed by the operator are considerably extended:

- Operation and understanding of the system
- Perform GNSS-supported machine positioning
  - Establish/check GNSS reception



- Transfer 3D model to controller
  - Understand data flows
- Estimate geological soil properties
  - Input to excavator control system

Summarizing the above-mentioned stages, Fig. 2 shows the new or transformed activities in the creation of an earthwork. The left-hand side shows the usual construction process, which was carried out in the past and is still being implemented in the same way today. The right-hand side shows the change in this task due to digitization and the associated systems, which are already being used as mentioned above or are expected to be used in the future.

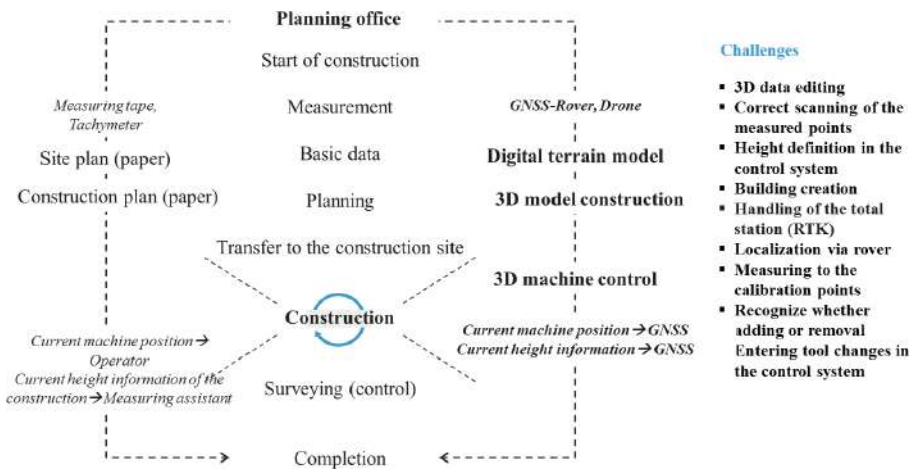

**Fig. 2.** Change in the tasks due to digitization when creating an earthwork

### 3.5 Challenges Due to Digitalization

The analysis shows how the complexity of the construction machine operator's job is increasing. Even the comparatively simple construction of a trench is becoming significantly more demanding due to the use of modern machines, sensors and surveying technologies. For the operator, this means that new work steps are added to the familiar ones or entire work steps are substituted. Two fields of action arise in order to integrate the new technologies into the application on the construction site. On the one hand, these are the workers with professional experience and, on the other, trainees.

For experienced workers, the use of digital solutions can become a challenge when activities such as data preprocessing on a laptop or on a machine are added, for example, to create a 3D building model. There is an acceptance barrier here that should not be

ignored, and this can lead to the systems not being used, especially by older employees. The experience of these users shows them that they have previously managed well without the systems that require digital work steps. Assistance functions are also not primarily part of facilitating systems for experienced construction equipment operators, even if the work could be carried out quickly and without problems in the past. This could change in the future, however, if more and increasingly complex tasks can be processed by the systems and not only relatively simple ones, as it has been the case up to now. In any case, there will be an increased need for training, especially in order to explain the advantages of digital solutions to the operators (e.g. excavator scales) or the owners (e.g. fleet management system).

The challenges for trainees are not so much due to a lack of acceptance by young operators as they are in the content of the training. Often, the new systems are not yet part of the curriculum, which can have various reasons. On the one hand, the framework curriculum does not yet provide for them, and on the other hand, the systems are not present in the company or in the training center and are therefore not known to the trainers. This requires a modernization of the teaching content, which in turn requires a new approach to teaching the new content. The claim to integrate current and future technologies as an object of appropriation in training and at the same time to develop new approaches to the (digital) design of teaching and learning processes, which includes the technical and didactic training of training personnel, implies a decidedly work task-related teaching and learning. The creation of task-related teaching-learning concepts requires the selection of exemplary sections of reality and the analysis of the teaching and learning potentials contained therein. First and foremost, the knowledge, skills and abilities that must be retrievable in the context of routine tasks and activities must be differentiated from those that are necessary in the context of problem-oriented tasks. Afterwards, an analysis from a didactic point of view has to take place in order to structure the knowledge. Subsequently, relevant factual and action-related contents are to be selected and appropriately combined with each other. This must be done in a high level of detail for different tasks. This shows that the implementation of the necessary teaching content is highly complex and costly from a didactic point of view. For further details, please refer to [5] where exactly this didactic implementation was discussed.

## 4 Summary

Intermediately the use of autonomous construction machines, which no longer require an equipment operator, is limited to a few areas of application. Automation solutions can therefore partially counteract the shortage of personnel, but qualified skilled workers for the operation and maintenance of construction machinery are still indispensable. However, with the increasing complexity of machine technology and the digitalization of the entire occupational field, the qualification requirements will increase massively. It is important to integrate new technologies, machine types and functions into training and qualification measures at an early stage in order, on the one hand, to teach the safe and efficient handling of new machines and construction processes and, on the other hand, to increase the acceptance of new technologies among all those involved in the process. This results in an increased need for new training and education concepts, which should

be complemented by modern equipment. In addition to the latest machine technology, this includes modern training tools such as interactive simulators and blended learning methods, which support both the scope and the quality of the training. This is realized through realistic training as a precursor to training on capital-intensive real machines. In addition, new and particularly critical situations can be trained on interactive simulators. This is often associated with a high risk for man and machine on the real machine.

Not only the operation of construction machinery is changing with technological change, but also the maintenance of the machines. Additional electrical and control technology components and completely new types of drive systems and components make it necessary to significantly increase qualifications. In this respect, the necessary activities in the fields of mechanics and hydraulics are not only changing due to knowledge in electrical and control engineering as well as power electronics, but must also be modified at the same time, parallel to technological development, at regular intervals.

The entire job profile of the construction equipment operator will change as a result of digitalization, i.e. the introduction and establishment of increasingly sophisticated, high-tech machines and work equipment. Added to this are changing and digitized work processes. Although the stressful external conditions, such as weather, noise and dust, will remain, the developments could increase the attractiveness of the construction professions for the younger generation. Digitalization can therefore be seen as an opportunity. At the same time, however, it presupposes corresponding innovative training.

**Acknowledgement.** The contents of this publication were developed within the project “DALiB”. This project is funded by the Bundesministerium für Bildung und Forschung (BMBF) as part of the special program “ÜBS-Digitalisierung”. The special program is carried out by the Bundesinstitut für Berufsbildung (BIBB).

## References

1. Oesterreich, T.D., Teuteberg, F.: Industrie 4.0 in der Wertschöpfungskette Bau – Ferne Vision oder greifbare Realität? In: Reinheimer, S. (ed.) Industrie 4.0. EH, pp. 71–89. Springer, Wiesbaden (2017). [https://doi.org/10.1007/978-3-658-18165-9\\_6](https://doi.org/10.1007/978-3-658-18165-9_6)
2. Starke, M., Waurich, V.: Einschätzung einschlägiger technologischer Entwicklungen im Baumaschinenbereich. Gesellschaft für Wissens- und Technologietransfer, Dresden (2021)
3. Marius Ramm, M.Ed.: Technologische Entwicklungen in der Landbautechnik. Heinz-Piast-Institut für Handwerkstechnik, Leibniz Universität Hannover, Hannover (2022)
4. Zinke, G.: Berufsbildung 4.0 - Fachkräftequalifikationen und Kompetenzen für die digitalisierte Arbeit von morgen: Branchen- und Berufescreening: vergleichende Gesamtstudie, 1. Auflage. Bundesinstitut für Berufsbildung, Bonn (2019)
5. Schweder, M., Starke, M., Waurich, V., Niethammer, M., Will, F.: Lehren und Lernen in der überbetrieblichen Baumaschinenausbildung. BAG-report, Bau Holz Farbe 2/2021, pp. 34–43 (2021)
6. Welzbacher, D.C., Pirk, W., Ostheimer, A., Bartelt, K., Bille, J., Klemmt, M.: Digitalisierung der Wertschöpfungs- und Marktprozesse – Herausforderungen und Chancen für das Handwerk (2015)
7. Industrie- und Handelskammer zu Dortmund. Rahmenplan Baugeräteführer\_in (2013)



# Introduction of an Assistant for Low-Code Programming of Hydraulic Components in Mobile Machines

Eva-Maria Neumann<sup>1</sup>(✉), Fabian Haben<sup>2</sup>, Marius Krüger<sup>1</sup>, Timotheus Wieringa<sup>3</sup>, and Birgit Vogel-Heuser<sup>1,4</sup>

<sup>1</sup> TUM School of Engineering and Design, Institute of Automation and Information Systems, Technical University of Munich, Boltzmannstr. 15, 85748 Garching, Germany

{eva-maria.neumann, marius.krueger, vogel-heuser}@tum.de

<sup>2</sup> Stadtwerke München, Emmy-Noether-Straße 2, 80992 Munich, Germany  
fabian.haben@protonmail.com

<sup>3</sup> HAWE Hydraulik SE, Einsteinring 17, 85609 Aschheim, Germany  
t.wieringa@hawe.de

<sup>4</sup> Core Member of MDSI, Member of MIRMI, Munich, Germany

**Abstract.** The increasing functionality of automation software in complex mechatronic systems such as construction machinery is a major challenge for companies to remain competitive. A major difficulty is that the software development in construction machinery often involves employees from different disciplines who have technological expertise about the process but little software background. Low-code platforms allow software to be developed intuitively without extensive programming knowledge. However, in mechatronics, the resulting programs are often facing the so-called scaling-up problem that occurs in case highly complex technical processes are implemented using graphical programming languages. This paper thus presents an assistant that supports the programming of automation software on low-code platforms to reduce the complexity of the resulting code. Static code analysis and machine learning are combined to enable predictions about software blocks to be used. For the example of the low-code platform eDesign, a graphical programming platform developed by HAWE Hydraulik SE, it is shown how users of the platform can be assisted in creating maintainable, reusable automation software in the construction machinery sector.

**Keywords:** mobile machines · construction machinery · low-code · visual programming languages · static code analysis · data mining · assistance system

## 1 Motivation and Introduction

The increasing complexity of automation software in mechatronic systems and the associated problems with code maintainability are a major challenge for companies to survive in the global market in the long term. A major difficulty is that the development of software for mechatronic systems often involves technicians who have technological

expertise about the process but little software background [1]. To this end, low-code platforms allow software to be developed via an intuitive graphical interface even without extensive programming knowledge, usually using *Visual Programming Languages (VPL)*. Although such platforms have already found their way into the world of automation technology, the resulting programs are often difficult to understand and maintain due to the high complexity of the technical processes to be controlled, leading to the so-called *scaling-up problem* in graphical languages [2]. In the field of high-level language software, there are already a large number of programming assistants to minimize the complexity of the code already during programming. For automation software in mechatronics, however, such approaches are hardly available so far [3]. This paper therefore presents a programming assistant that supports the programming of automation software on low-code platforms to reduce the complexity of the resulting code. To develop the system, approaches from static code analysis and machine learning were combined to enable predictions about software blocks to be used and optimal assistance for the user. Using the low-code platform eDesign, a graphical programming platform developed by HAWE Hydraulik SE, it is demonstrated how users of the platform can be assisted in creating maintainable, reusable automation software in the construction machinery sector. The assistance is provided on three levels:

- *Calculation and display of complexity metrics*: By quantitatively evaluating various properties of the graphical programs, the user receives direct feedback on which adjustment screws can improve comprehensibility.
- *Encapsulation of recurring function block combinations*: If recurring sub-functions consisting of several function blocks are identified in a project, they can be encapsulated in one function block, thus significantly reducing complexity.
- *Suggestions for function blocks to be used*: Based on machine learning algorithms, the programming assistant learns from the structure of existing projects and can thus generate live suggestions for function blocks to complete the program during programming.

The presented paper enlarges previous results published in [1] by providing more details on the implemented programming assistant and a concrete.

## 2 State-of-the-Art in Analyzing and Assisting Low-Code Development

Static code analysis is an established lever to identify optimization potentials without executing the code and quantifying specific quality characteristics [2], e.g., using software metrics. However, in the field of VPL, static code analysis is not yet widespread and existing approaches are often tailored to an individual language, such as MathWork's *Model Metrics* [3] for Simulink. Besides the syntactical program composition, also the layout quality strongly influences a VPL program's understandability, i.e., the visual arrangement of blocks and their connections. Taylor et al. [4] propose a set of metrics to quantify the graphical design quality. In the field of IEC 61131-3 compliant automation software, Capitán and Vogel-Heuser [5] use metrics adapted from IEC 61131-3 by Halstead [6] and McCabe [7], as well as metrics by Henry and Kafura [8] and the Module

Size Uniformity Index (MSUI) by Sarkar et al. [9]. Fischer et al. [10] investigate the overall complexity of graphical and textual IEC 61131-3 software. For this purpose, several metrics are used that evaluate different classes of software complexity. A common approach to reducing complexity is the encapsulation of recurring functionalities in reusable units. Duplicated code or so-called *code clones* in the software can be a hint for recurring functionalities that are reused via *Copy, Paste & Modify*, and, thus, can be a starting point for standardization [11]. One of the first algorithms for finding clones in graph-based modeling languages is *CloneDetective* [12], which can be adapted to various textual programming languages and also to VPLs such as Simulink. However, this requires suitable translators for each VPL. Recently, Rosiak et al. introduced an approach capable of identifying code clones in graphical IEC 61131-3 languages based on similarity metrics [13], which, however, does not provide live assistance during programming. There is a variety of approaches from static code analysis to identify highly complex or duplicated code structures in VPL and low-code, but available methods are usually tailored to specific VPL and cannot be transferred to other languages without adaptations. Additionally, assistance or suggestions to compensate high complexity values is usually not included.

*Data mining* is the process of finding functional structures in existing data and is thus ideally suited for extracting knowledge from code analysis data that can be used to build programming assistants. Bruch et al. [14] use data mining to derive suggestions for the programmer based on existing projects by analyzing the context, the frequency of calls to existing methods, and rules derived from previous projects. Further approaches to formulate suggestions to complete code during programming are based on natural language processing [15] or neural networks [16, 17]. The *SimVMA* system for Simulink [18] is capable of predicting complete systems in an early stage based on partially implemented systems and generates individual next steps as suggestions. The approach from Deng et al. [19] is based on the analysis of subgraphs in available projects in a graph-based representation. On this basis, a structure table is created that includes the subgraph leading to a selected node, the possible subsequent nodes, and the confidence for each combination. When a node is selected by the user, a similarity of the corresponding subgraph is calculated for all subgraphs in the structure table. Potential candidates can then be prioritized by confidence. Due to the promising results, this approach [19] is used as a basis to derive the proposed programming assistant. Regarding commercial tools, the generation of suggestions of elements to be used next has been established since long for textual languages, e.g. Visual Studio's *ReSharper* [20]. For VPL, however, commercial programming assistants to support the programmer are rare. Low code platforms such as Siemens *Mendix* [21] allow the simple programming of applications for different fields, but no assistance, e.g., based on data analysis of existing projects is provided.

In summary, there are different concepts to support programmers during writing the code by providing suggestions. However, to the best of the authors' knowledge, there is up to now no approach for low-code platforms that combines assistance to automatically quantify complexity, identify reuse potentials, and provide live recommendations during programming. Thus, this paper enlarges the previously introduced programming assistant by the authors [1] by providing additional details on the implementation as well as the practical usage of the assistance in a user study.

### 3 Concept of a Programming to Develop Low-Code

To allow the user to objectively quantify program complexity during programming, find and replace code duplicates within a project, and generate suggestions for blocks to be used next, a general concept for a programming assistant is proposed that can be tailored to any VPL that is representable as nodes connected by edges. The concept involves a two-step approach (see Fig. 1): Before the creation of a new project, i.e., *pre-coding*, knowledge is extracted from previous projects to enable different types of assistance functions for programmers *during coding*.

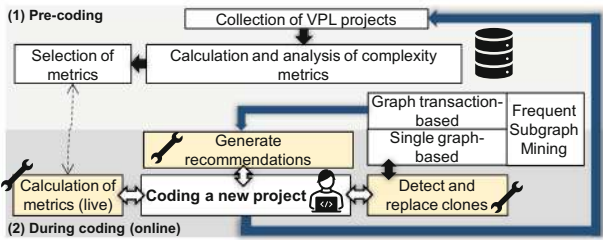

Fig. 1. Overview of the two parts to of the low-code programming assistant (adopted from [1])

In the *pre-coding*, a data basis of available projects is required that initially need to be transformed to a graph-based representation. This is the basis to select complexity metrics that shall be displayed for the user when developing code. Additionally, *frequent subgraph mining* is performed on the collected projects to generate a basis to derive suggestions during programming. More precisely, a *graph-transaction based* approach is followed. *During Coding*, the user is supported live during programming in a low-code environment based on the data set established in the previous phase: Complexity metrics are calculated for the whole project and updated whenever the project is changed. Additionally, duplicated code parts are identified that can be encapsulated as reusable blocks. Finally, suggestions for blocks to use next are proposed as soon as the developer clicks on an existing block in a given project. For details on the applied code analysis and data mining methods, please refer to [1].

### 4 Prototype of the Programming Assistant

The following section illustrates the implementation of the programming assistant by means of a prototype on the example of the low-code platform HAWE eDesign. eDesign aims to facilitate the programming of hydraulic components by providing different function blocks connected via ports (cf. Fig. 2).

As a basis for selecting complexity metrics and the suggestion of blocks, a data basis of 1,269 anonymized eDesign user projects has been analyzed during the Pre-Coding phase (cf. Fig. 1). For the pre-analysis of the projects, the metric values are determined with a *Python Jupyter Notebook* [22] based on different sources. In addition to the graphical representation of eDesign, there is a textual intermediate representation



of the programs in the high-level C language, which allows the application of analysis techniques for textual languages. In this case, *multimetric* [23] is used to calculate complexity metrics for the C code. Additionally, metrics for the graphical representation are complemented based on the Python library *Network X* [24] and by own implementation of the metrics of Taylor et al. [4] and further metrics in C#. Based on a statistical pre-analysis of the projects, it is concluded that the three Halstead metrics *Vocabulary*, *Length*, and *Difficulty* as well as McCabe's *Cyclomatic Complexity* and the *Overall Layout Quality* according to Taylor reveal the most significant insights into the projects' complexity and, thus, will be included in the programming assistant.

The programming assistant is developed in C# and allows programming new projects in a low-code environment similar to HAWE eDesign. To evaluate the proposed concept, the different sub-concepts of the programming assistant must be usable during the programming of new projects. This requires an additional connection to the associated web application. To calculate the metrics based on the graphical representation of the program, projects from HAWE eDesign can be loaded into the prototype. During the import, the previously selected metrics are automatically calculated. Thus, all calculated metrics for a project can be bundled by the prototype and exported in a single file (cf. *Area 5* in Fig. 2).

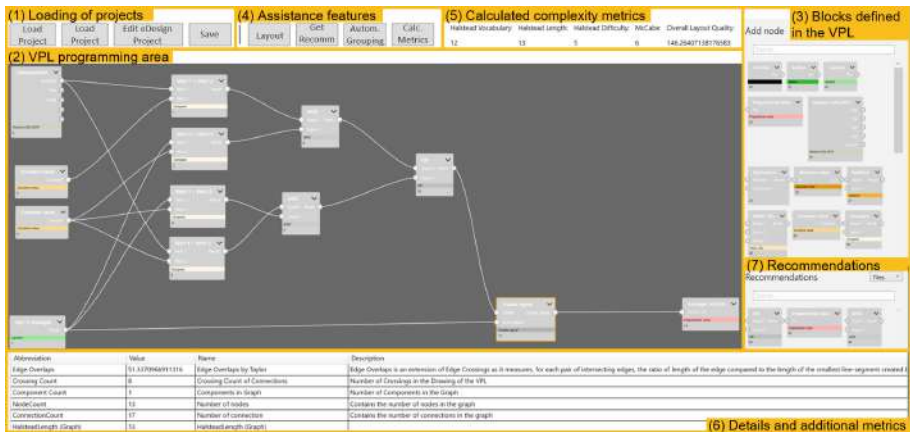

**Fig. 2.** Prototypical implementation of the programming assistant for the example of the low-code environment HAWE eDesign (areas 1–7 highlighted in yellow; adopted from [1]) (Color figure online)

*Area 1* allows loading and creating new projects. Once a new project has been loaded or created, programming can be done in *Area 2*. In *Area 4*, various functions can be started manually, such as the calculation of metrics or the automatic grouping. The metrics in *Area 5* are automatically updated once the program structure is changed. In *Area 6*, other metrics can be displayed, such as the individual values of the overall quality of the design. *Area 3* shows all possible blocks that have been implemented in the prototype and can therefore be used for programming. To use them, simply drag and drop them into the programming area. Below, in *Area 7*, the candidates of the proposed assistant



are shown. These are calculated as soon as a block is selected. In contrast to the original VPL used in HAWE eDesign, groups encapsulating several blocks can be created as a starting point for standardization in this implementation. The groups thus created can continue to be used in the program in the same way as existing blocks.

## 5 Evaluation in User Study

The prototypically implemented programming assistant was evaluated in a user study with ten students with a background comparable to that of the focused dedicated specialists (pronounced technical process knowledge but little programming skills). The benefits of the programming assistant were assessed in four programming tasks and a subsequent survey. The participants were divided into two groups – *Group 1* worked on the programming tasks with assistance, *Group 2* without assistance. Figure 3 shows an example for the sample solution of a task to reuse a certain functionality (in this case: limitation based on logical operators) in different parts of a given project. The possibility to encapsulate and reuse functionality with the assistance activated in *Group 1* leads to a significantly reduced complexity compared to *Group 2*.

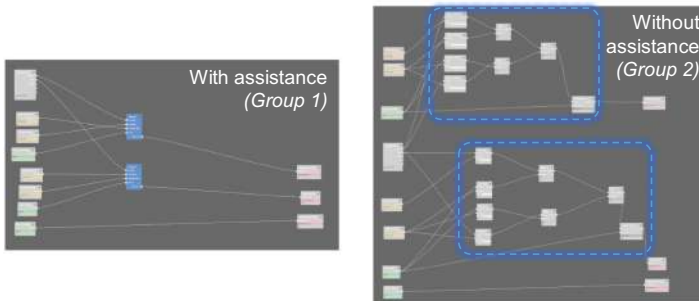

**Fig. 3.** User support in the programming assistant to reduce complexity by encapsulating reusable functionality in *Group 1* (blue blocks left) compared to reuse without encapsulation via *Copy & Paste* in *Group 2* (blue dotted areas right). Reusable functionality was automatically identified in *Group 1* via clone detection.

The user study confirmed that the use of the programming assistant led to considerable time savings of approx. 54% on average based on time measurements in both groups for the completion of each of the given tasks. Additionally, the features of the programming assistant were perceived as helpful overall. In the future, however, further analyses are required with industrial practitioners using eDesign in their daily development work to program hydraulic components.

The findings of the user study were confirmed in an industry workshop with three developers from HAWE eDesign to evaluate the concept from the perspective of low code platform developers. The workshop confirmed that from the point of view of the interviewed industry experts, the programming assistant is considered helpful and applicable for their customers.

## 6 Conclusion and Outlook

This paper presents a concept for a programming assistant to support dedicated specialists with sophisticated process knowledge but little programming experience in developing software in low-code platforms by metric-based complexity assessment, encapsulation of code duplicates, and suggestions for blocks to be used live during programming, thus reducing the scaling-up problem in VPL. Using the example of the low code platform HAWE eDesign, the applicability and advantages of the assistance have been successfully evaluated in a study with users emulating dedicated specialists and an additional workshop with industry experts.

Current research in the context of Industry 5.0 highlights the importance of supporting humans with innovative approaches from automation to cope with shortened innovation cycles and the increasing system complexity, especially regarding the increasing scope of functionality implemented via software. Since knowledge of the technical process is becoming increasingly important in software development for mechatronic systems, software will increasingly be written by dedicated specialists without in-depth programming knowledge. Thus, the relevance of low code platforms is expected to increase in the next year. Therefore, future work is required to adopt the implementation of the proposed concept of a programming assistant for further VPL and low-code platforms by considering users with different background and degree of qualification.

**Acknowledgment.** This work was supported by the Bavarian Ministry of Economic Affairs, Energy and Technology via the project *AIValve* (Grant No. DIK0116/01).

## References

1. Neumann, E.-M., Vogel-Heuser, B., Haben, F., et al.: Introduction of an assistance system to support domain experts in programming low-code to leverage industry 5.0. *IEEE RA-L* **7**, 10422–10429 (2022)
2. Nachtigall, M., Nguyen Quang Do, L., Bodden, E.: Explaining static analysis - a perspective. In: *IEEE/ACM International Conference on Automated Software Engineering Workshop (ASEW)*, pp. 29–32. IEEE (2019)
3. MathWorks Model Metrics. <https://de.mathworks.com/help/slcheck/model-metrics.html>. Accessed 14 June 2023
4. Taylor, M., Rodgers, P.: Applying graphical design techniques to graph visualisation. In: *9th International Conference on Information Visualisation*, pp. 651–656. IEEE (2005)
5. Capitán, L., Vogel-Heuser, B.: Metrics for software quality in automated production systems as an indicator for technical debt. In: *IEEE CASE*, pp. 709–716. IEEE (2017)
6. Halstead, M.H.: *Elements of Software Science*. Elsevier Computer Science Library. Operating and Programming Systems Series, vol. 2. Elsevier, New York and Oxford (1977)
7. McCabe, T.J.: A complexity measure. *IEEE Trans. Softw. Eng.* **SE-2**, 308–320 (1976)
8. Henry, S., Kafura, D.: Software structure metrics based on information flow. *IEEE Trans. Softw. Eng.* **SE-7**, 510–518 (1981)
9. Sarkar, S., Rama, G., Kak, A.: API-based and information-theoretic metrics for measuring the quality of software modularization. *IEEE Trans. Softw. Eng.* **33**, 14–32 (2007)
10. Fischer, J., Vogel-Heuser, B., Schneider, H., et al.: Measuring the overall complexity of graphical and textual IEC 61131-3 control software. *IEEE RA-L* **3**, 5784–5791 (2021)

11. Ain, Q.U., Butt, W.H., Anwar, M.W., et al.: A systematic review on code clone detection. *IEEE Access* **7**, 86121–86144 (2019)
12. Juergens, E., Deissenboeck, F., Hummel, B., et al.: Do code clones matter? In: *IEEE ICSE*, pp. 485–495. *IEEE* (2009)
13. Rosiak, K., Schlie, A., Linsbauer, L., et al.: Custom-tailored clone detection for IEC 61131-3 programming languages. *JSS* **182**, 1–18 (2021)
14. Bruch, M., Monperrus, M., Mezini, M.: Learning from examples to improve code completion systems. In: *Meeting of the European Software Engineering Conference and the ACM SIGSOFT Symposium on the Foundations of Software Engineering*, p. 213. *ACM Press, New York* (2009)
15. Raychev, V., Vechev, M., Yahav, E.: Code completion with statistical language models. In: O’Boyle, M., Pingali, K. (eds.) *Proceedings of 35th ACM SIGPLAN PLDI*, pp. 419–428. *ACM, New York* (2014)
16. Svyatkovskiy, A., Zhao, Y., Fu, S., et al.: Pythia: AI-assisted code completion system. In: Teredesai, A., Kumar, V., Li, Y., et al. (eds.) *25th ACM SIGKDD KDD*, pp. 2727–2735. *ACM, New York* (2019)
17. Kalyon, M.S., Akgul, Y.S.: A two phase smart code editor. In: *IEEE HORA*, pp. 1–4. *IEEE* (2021)
18. Stephan, M.: Towards a cognizant virtual software modeling assistant using model clones. In: *IEEE/ACM 41st ICSE-NIER*, pp. 21–24. *IEEE* (2019)
19. Deng, S., Wang, D., Li, Y., et al.: A recommendation system to facilitate business process modeling. *IEEE Trans. Cybern.* **47**, 1380–1394 (2017)
20. Koch, M.: Inspections and Quick-Fixes in ReSharper (2021). <https://www.jetbrains.com/dotnet/guide/tutorials/resharper-essentials/inspections-quick-fixes/>. Accessed 14 June 2023
21. Siemens Mendix. <https://www.plm.automation.siemens.com/global/de/products/mendix/>. Accessed 14 June 2023
22. Python Jupyter Notebook. <https://jupyter.org/>. Accessed 14 June 2023
23. Python multimetric. <https://pypi.org/project/multimetric/>. Accessed 14 June 2023
24. Python NetworkX. <https://networkx.org/>. Accessed 14 June 2023



# Decarbonizing Construction Material Supply Chains: An Innovative Approach to Intermodal Transportation

Philipp Miklautsch<sup>1</sup>(✉), Manuel Woschank<sup>1</sup>, and Julia Heißenberger<sup>2</sup>

<sup>1</sup> Chair of Industrial Logistics, Montanuniversitaet Leoben, Erzherzog-Johann-Straße 3/1, 8700 Leoben, Austria

philipp.miklautsch@unileoben.ac.at

<sup>2</sup> W. Riedel Silo-Transport GmbH, Triesterstrasse 381, 8401 Feldkirchen bei Graz, Austria

julia.heissenberger@siloriedel.at

**Abstract.** The transportation of construction materials is a crucial part of the construction material supply chain and a major contributor to greenhouse gas emissions from transportation. In Austria, for example, around 11% of the goods transported in 2020 were mineral products, such as glass, cement, lime, and plaster - much of which are demanded by the construction industry. Some of those goods are bulk materials that are well suited for high-capacity means of transport, e.g., trains. However, several system characteristics of the railroad severely limit its use on the last mile to the customer. Here, materials need to be delivered in a timely and efficient manner to ensure that projects stay on schedule and within budget. An eligible solution for this is intermodal transportation, which couples the benefits of efficient rail haulage with flexible road haulage. Nevertheless, conventionally used 30-foot silo containers hinder high utilization of trains due to weight limit excess of trucks. Therefore, a novel 22.5-foot container design for the transportation of cement was introduced recently that enables a high-capacity utilization of trucks and trains. In this article, we present the environmental impact of its use in construction material transportation by quantifying greenhouse gas emissions of an exemplary use case in the Austrian construction industry. Results show emission mitigation potentials of 75% to 93%, depending on several parameters. This article contributes to the scientific literature by bringing evidence on emission reduction potentials in the construction material supply chain and elaborating on the determining factors.

**Keywords:** combined transport · construction material · industrial logistics · climate change · greenhouse gas emissions

## 1 Introduction

The Synthesis Report for the Sixth Assessment Report of the IPCC draws a clear and alarming call for urgent action to reduce greenhouse gas (GHG) emissions

in the coming decade to hinder the most threatening and irreversible impacts of climate change on humanity. According to the report, emissions need to peak before 2025, highlighting the necessity to implement near-term mitigation actions on time [1].

Investigating the sources of global GHG emissions shows that the transportation sector accounts for around 15–16% [2, 3], being one of the hardest sectors to decarbonize [4]. Especially regarding freight transportation, the choice of effective near-term measures is limited. Literature and practice intensively discuss various methods to power future vehicles with renewable energy, the most famous of which being electricity and hydrogen. Although these options are promising and inevitable in the long-term, they are not expected to have a significant impact in the coming years in any of the world's regions [4]. Nevertheless, the avoidance of unnecessary transportation operations through consolidation and bundling, as well as the shift away from road transportation to less carbon-intensive modes were shown to have deep carbon emission reduction potentials [5] and are thus promising for near-term decarbonization.

In Europe, the infrastructure for railways is well-established [6], indicating that the shift towards rail transportation is a viable option in the European Union. However, several barriers impede the transition to rail transport. One obstacle is that the number of direct connections from manufacturing companies to the railroad is declining, indicating that only a small number of consignees and consignors have direct access to the rail network [6]. Furthermore, train deliveries are scheduled - and sometimes delayed, which makes them less flexible, making it difficult to achieve Just-in-Time (JIT) shipments [7]. Challenges regarding the access to the rail network and the timeliness can thereby be overcome by utilizing combined road-rail transportation (CRRT). It allows for the first or last mile to be flexibly transported by truck, and the goods to be buffered at the terminals and delivered JIT. The main challenge in CRRT is thereby the efficient cargo transshipment between the two modes of transport [8] to minimize the break-even distance [9], as well as the utilization of railway cars and truck trailers with the same load unit. Nevertheless, the railway system was initially installed - and is still optimized - for the transportation of heavy and bulky goods over long distances [10]. Regarding the construction material supply chains (CMSC), rail transportation is thus best suited for materials such as cement, lime, and plaster. In Austria, those goods account for around 11% of the goods transported in 2020 [11]. To ensure a flexible delivery, they are mostly transported in silo containers - which scored poorly in terms of their intermodal capabilities.

To increase the efficiency of CRRT for silo transportation, a new load carrier design was introduced lately by InnoFreight Solutions GmbH, which is tailored to the typical customers' needs. The "CemTainer" was specifically designed to transport cement via CRRT. On the one hand, it enables efficient handling and, on the other hand, the full utilization of railway cars and trucks. To investigate the environmental impact of CRRT usage in the CMSC, we elaborate the GHG emissions in an exemplary transport chain of cement in Austria. For practitioners, results provide an insight in the emission reduction potential of CRRT in

short- to medium-distance transportation in the CMSC. For researchers, results indicate further research directions and point to weaknesses in current emission quantification guidelines when applied to CRRT.

In the following section, the results of an initial literature review are presented briefly. Subsequently, the exemplary transport chain and the methodology to quantify GHG emissions are outlined, followed by its results and a brief discussion.

## 2 Literature Review

### 2.1 Green Transportation in the Construction Material Supply Chain

Logistics and transportation are crucial aspects for the success of a construction project as they impact the delivery time, cost, and quality of the materials (e.g., [12]). Thus, optimization of the CMSC can increase construction projects' resilience [13]. Besides economic aspects, the environmental footprint of construction projects is a rising issue for researchers and practitioners (e.g., [14]). Green transportation was found to be one key element of reducing environmental impacts of construction projects (e.g., [15]). Thereby, a main research stream concentrates on logistics network measures to enhance freight consolidation and bundling. Initially introduced to deal with rising traffic congestion issues (e.g., [16]), bundling and consolidation are meanwhile an important part of reducing transportation costs and emissions. For example, Construction Consolidation Centres enjoy increasing popularity, being intended to relieve inner-city traffic and reduce the environmental impacts of urban CMSC transportation activities [17]. Besides those approaches, construction material transportation practitioners report, for example, on introducing circular approaches for pallets [18], highlighting the relevance to focus on improving existing logistics structures towards sustainability.

### 2.2 Combined Transportation

The term “combined transport” refers to a method of transporting goods that involves consolidating them at regional hubs, transporting them to another hub in a different region, and redistributing them to local nodes. While this type of transportation generally involves at least two modes [19], European legislation defines specific combinations of modes that qualify as combined transport. Thereby, combined transport needs to involve truck transportation on the first and/or last leg, and transportation by rail, inland waterway, or maritime services on the main leg. Furthermore, it is required that solely lorries, trailers, semi-trailers (with or without a tractor unit), swap bodies, or containers of 20 ft or more are transshipped [20].

Using combined transportation for bulk materials is preferred for long-distance routes, for example in inter-state grain silo transportation [21], as the

specific costs of the train are 30–35% lower than those of road freight [9]. Thus, the efficiency of the transshipment activities at hubs defines the length of the break-even distance and is thereby one determining factor of the competitiveness of CRRT [8]. Another decisive factor is the utilization of vehicles, as a higher load reduces specific costs of good transportation, and thus overall logistics costs (see, e.g., [22]). Nevertheless, using CRRT complicates the transport chain, as more parties are involved. This implies an increased risk of longer delivery times, which can be contradictory to JIT and has to be monitored carefully [23].

### 2.3 A Novel Load Carrier Design

Due to the aforementioned aspects, this article elaborates on different options to use a novel load carrier design for CRRT in CMSC. Information regarding the so-called “CemTainer” was provided to the authors by internal documents. The CemTainer is a 22.5 ft-long container with a C22 profile, equipped with standard interfaces for handling and transport. This profile is common for intermodal load carriers, as it is also used in 30 ft open-top containers [24], the 30 ft AgroTainer [25] or the 20 ft ChemieTainer [26]. The high volume of 32 m<sup>3</sup> and the compact design allows the maximum permissible total weight of the trucks to be utilized while maximizing the number of containers on the rail car. By providing this combination, both means of transport in CRRT can be utilized to their full capacity, enabling cost-competitive combined transport. The standard handling interfaces allow for little handling fees, as they can be handled by reach stackers or gantry cranes. Last-mile truck transport and the possibility of pressure unloading by tipping the CemTainer make its use flexible for different customer sites, also in urban areas and on construction sites. As the typical customers for cement silo transportation are large construction sites or concrete plants with high demand, the large delivery volume further meets the customers’ needs.

## 3 Methodology

In the following section, we present the evaluation of GHG emissions with different scenario configurations. First, the scenarios and the parameter variation are described. Subsequently, the methodology to calculate emissions is discussed.

### 3.1 Description of the Scenarios

The scenarios evaluated in this article are based on a real-world case from an Austrian transport company specializing in silo transportation. The focal case thereby describes the transportation of cement from one cement plant to different customers like concrete plants or large construction sites. To simplify the calculation, we assume a representative customer in the center of gravity of all possible customers as the transport destination. Since the area of possible customers is close to an urban center, this consideration hardly distorts the results. In Fig. 1, the two transport chain configurations are visualized.

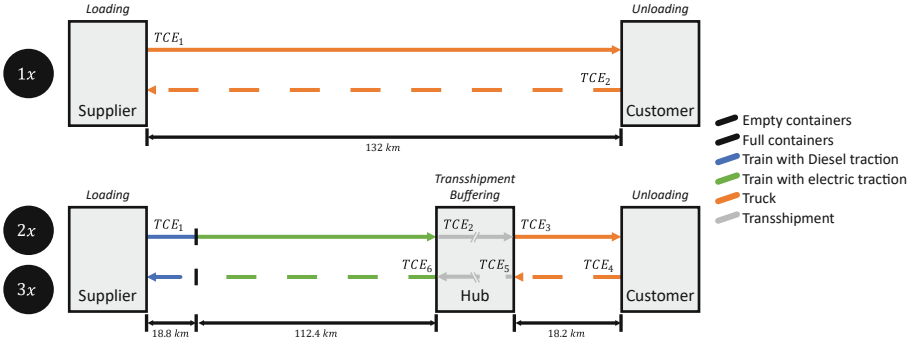

Fig. 1. An overview of the scenarios covered

Scenarios 1a to 1c represent the base case, conducting transportation by truck only. Thereby, the maximum permissible cement weight is loaded onto the truck at the cement plant and a distance of  $d_1 = 132$  km must be driven by road. Currently, there is no possibility to refill the load carriers near the customers and backhaul goods, which necessitates the empty trip of  $d_1 = 132$  km back to the cement plant.

Scenarios 2a to 2c and 3a to 3c represent the CRRT case, shifting the main leg to rail while still delivering the goods JIT to the customers through truck transportation on the last mile. The train line includes an unelectrified branch line that connects the plant to the electrified main line, which results in a total rail distance of  $d_{2,rail} = 131.2$  km. As the hub is located slightly outside the city centre, the truck needs to drive another  $d_{2,road} = 18.2$  km, which results in a slightly increased overall distance traveled of  $(d_{2,rail} + d_{2,road}) - d_1 = 149.4$  km for the containers in the CRRT scenarios.

The connecting entity between those two transport modes is the hub, having a transshipment and a buffering function. Transshipment equipment thereby stores incoming full containers from the train in a buffer zone and - when requested - loads those units on trucks driving to the customers. Conversely, empty containers from the customers are buffered at the hub until a block train takes them back to the cement plant. As all containers cycle through this loop, four hub operations are necessary for each container: the full container is transhipped from the train to the buffer zone from the buffer zone to the truck. Similarly, the empty container is transhipped from the truck to the buffer zone and from the buffer zone to the train. According to [27], these operations need to be included in the emission calculation of intermodal transport chains. The emissions thereby depend on the energy consumption and the fuel emission intensity - which depends on the type of equipment used. Thus, scenarios 2x and 3x differentiate by the main handling equipment in the hubs. Hub operations in the scenarios 2x are conducted by Diesel-powered reach stackers, whereby hubs in the scenarios 3x use electrified rail-mounted gantry cranes (RMGC).



Besides shifting transport from road to rail, another frequently discussed measure to decarbonize transportation is the usage of alternative fuels and drivetrains [5]. Thus, for each scenario group  $1x$ ,  $2x$  and  $3x$ , we compare three possible combinations of such: First, the  $a$ -scenarios present the base case, using conventional internal combustion engines with Diesel B7 (Diesel with about 7% Biodiesel share). Second, the  $b$ -scenarios use Hydrotreated Vegetable Oil (HVO), an advanced biofuel that can be used in conventional internal combustion engines. Third, trucks in the  $c$ -scenarios are powered by electric drivetrains. Table 2 in the appendix provides an overview of the scenario parameters.

### 3.2 GHG Emission Quantification

To quantify GHG emissions from the transport chain, we adhere to [27]. It requires breaking down the transport chain into “the discrete, sequential transport chain elements (TCEs) that reflect the related vehicle types, pipelines or hubs that carry, handle or transfer the freight and/or the passengers as part of the whole transport chain” [27], p. 19). Each TCE is either a hub operation of a certain hub operation category (HOC) or a transport operation of a transport operation category (TOC). Each HOC or TOC thereby defines a set of operations with similar characteristics regarding the transport mode, hub type and freight type. Different energy carriers can be used in a TOC, which is why we define the TOCs as follows:

- $TOC_{t,d}(fuel)$ : Truck delivery of one container from the cargo consignor to the cargo consignee or vice versa, whereby the truck is powered by  $fuel$
- $TOC_{r,c}$ : Rail delivery of several containers from the cargo consignor to the hub or vice versa
- $TOC_{t,c}(fuel)$ : Truck delivery of one container from the hub to the cargo consignee or vice versa, whereby the truck is powered by  $fuel$

A HOC shall group hub activities according to their characteristics, e.g., the number or the nature of hub operations included in the HOC. As of these requirements, we define two HOCs for our scenarios:

- $HOC_{RS}$ : Unloading a container from an incoming vehicle, transporting it to an interim storage location, receiving it from this location, and loading it to the outgoing vehicle - by using a Diesel-powered reach stacker.
- $HOC_{RMGC}$ : Unloading a container from an incoming vehicle, transporting it to an interim storage location, receiving it from this location, and loading it to the outgoing vehicle - by using an electrified RMGC.

We thereby define the transport chains as presented in Table 3 in the appendix and model the emissions by a bottom-up energy-based approach [27]. With this approach, for each TOC, the emissions of all energy consumers involved in the activities  $A_i$  of the TOC are summed up - taking into account the emissions of the vehicle energy provision

$$G_{VEP,TOC,A_i} = Q_{TOC,A_i} \times \epsilon_{VEP,A_i}$$

as well as the emissions of the vehicle operation

$$G_{VO,TOC,A_i} = Q_{TOC,A_i} \times \epsilon_{VO,A_i}$$

Thereby,  $Q_{TOC,A_i}$  is the quantity of GHG activity type  $A_i$ , e.g., the amount of Diesel or electricity,  $\epsilon_{VEP,A_i}$  is the emission intensity of energy provision, and  $\epsilon_{VO,A_i}$  is the emission intensity of the vehicle operation phase. Summed up,  $G_{TOC} = \sum_i G_{VEP,TOC,A_i} + \sum_i G_{VO,TOC,A_i}$  provides the emissions of the TOC. A similar approach is considered for the hub operations. In the following paragraphs, we elaborate on the most important parameters for the quantification of GHG emissions throughout the scenarios. For the calculation spreadsheet including the detailed references refer to the appendix.

**Energy Consumption Data:** Energy consumption data  $Q$  of the transportation equipment is taken from the EcoTransIT methodology report [28], Table 22 and Table 26. For the energy consumption of the hub equipment, we requested internal information from our partners, which we were able to cross-validate by different publications. For details, see the calculation spreadsheet which is linked in the appendix.

**GHG Intensity of Diesel B7:** In Austria, the Diesel sold in 2021 had an average Biodiesel share of 6.02% concerning the energy content [29]. Considering data from [30], this results in a GHG intensity of  $\epsilon_{B7} = \epsilon_{VO,B7} + \epsilon_{VEP,B7} = 88.51 \text{ gCO}_2\text{e/MJ} = 3.16 \text{ kgCO}_2\text{e/l}$ .

**GHG Intensity of HVO:** To be eligible as a transportation biofuel, a fuels' emission intensity must be 65% lower than the reference value of  $94 \text{ gCO}_2\text{e/MJ}$ , which leads to a maximum permissible emission intensity of  $\epsilon_{HVO} = \epsilon_{VO,HVO} + \epsilon_{VEP,HVO} = 32.90 \text{ gCO}_2\text{e/MJ}$  [31]. The actual emission factor depends on the specific fuel used. The authors were provided HVO certificates proving that emissions can be lowered by 85% to  $13.2 \text{ gCO}_2\text{e/MJ}$ . Nevertheless, as these reductions are rather uncertain, we use the conservative upper boundary for our estimations - possibly overestimating the emissions from the  $b$ -scenarios.

**GHG Intensity of Electricity:** Different emission factors for electricity are available, an excerpt of which can be found in Table 4 in the appendix. Due to the multiplicity of possible references, we use the emission factor published by the Austrian Environmental Agency [32] for road transportation by electric vehicles  $\epsilon_{E_{truck}} = \epsilon_{VEP,E_{truck}} = 17.666 \text{ gCO}_2\text{e/MJ}$ . The usage of this reference is also required by the Austrian Fuel Ordinance to calculate the emission intensity of fuels, which we use for the quantification of HVO emissions. Thus, the value from this source appears to be the most comparable - and the most recent. For railway transportation, we use the factor provided by [28] of  $\epsilon_{E_{rail}} = \epsilon_{VEP,E_{rail}} = 49 \text{ gCO}_2\text{e/MJ}$ , as it is the most specific factor we can determine.

## 4 Results and Discussion

### 4.1 Results

Table 1 presents the calculation results. Thereby, the emissions of the base-case in scenario 1a, transportation by truck with conventional fuel, stand out. Fuelling the trucks with pure HVO may thereby decrease emissions by nearly 63%. Replacing the combustion engine with an electric one reduces emissions to about 10% of the base case' ones. The combined transportation scenarios 2a to 3c highlight a GHG mitigation potential of 75% to 93% - depending on the utilized truck fuel and hub equipment. If RMGC are used for transshipment, the emissions of the transport chain are about 6% points lower than when handling with Diesel-powered reach stackers. This is due to the lower energy consumption and the lower emission intensity of electricity. In Fig. 2 in the appendix, the results of the GHG quantification are visualized.

**Table 1.** GHG quantification results

Scenario	HOC	Truck fuel	Emissions/ $kgCO_2e$		Reduction
			per year	per 1000 kg	
1a	none	Diesel B7	4 238 615.30	10.60	0.00%
1b	none	HVO	1 575 533.20	3.94	62.83%
1c	none	Electricity	427 583.64	1.07	89.91%
2a	$HOC_{RS}$	Diesel B7	1 032 233.71	2.58	75.65%
2b	$HOC_{RS}$	HVO	692 582.65	1.73	83.66%
2c	$HOC_{RS}$	Electricity	545 389.98	1.36	87.13%
3a	$HOC_{RMGC}$	Diesel B7	779 804.72	1.95	81.60%
3b	$HOC_{RMGC}$	HVO	440 153.67	1.10	89.62%
3c	$HOC_{RMGC}$	Electricity	292 960.99	0.73	93.09%

### 4.2 Discussion

Scenarios 1 and 2 highlight the large emission reduction potential of CRRT when using internal combustion engines in truck operations. As emission intensities of truck operations sink, the impact of hub operations on GHG emissions becomes evident. Thus, the comparison of the  $c$ -scenarios is interesting: Once battery electric trucks are broadly utilized, the hub equipment will determine whether CRRT is beneficial or detrimental to the environment on short- to medium-distances. The combination of low emissions from road transport and high emissions from the hub is responsible for the fact that combined transport in scenario 2c has more emissions than direct transport by truck in scenario 1c. Nevertheless, as long as the specific emissions of the train are lower than those

of the truck, a certain break-even distance regarding GHG emissions exists, but the transport chain in this paper is too short to reach this distance in scenario 2c. Furthermore, the effects of Diesel-powered trains becomes visible in this case. The graph of cumulative emissions in the appendix (Fig. 2) in the first section of rail transportation in scenarios 2c and 3c is steeper than the one in scenario 1a, highlighting the importance to shift transportation to electrified train tracks. The usage of Diesel-powered trains reduces emissions compared to conventional truck technologies (i.e., in the *a*- and *b*-scenarios), but increases emissions compared to battery electric trucks.

### 4.3 Limitations

Regarding hub operations, we assume only two handling operations per transshipment activity and thereby neglect inter-terminal operations that may be necessary due to the operational characteristics of the terminal. The real number of necessary handling operations to transship one container depends on different factors and differs between terminals. In addition to the number of handling operations, emissions from other operational and administrative activities (e.g., fuel use for inter-terminal transportation or office lightning and heating) are neglected. These depend on the processes of the respective terminal and can vary considerably in some cases. For this reason, we did not investigate the use of lower-carbon alternatives for the hub operations, e.g., HVO-powered reach stackers. Furthermore, the quantification results are sensitive to a change in the input emission intensities  $\epsilon$ . As mentioned above, HVO could lead to much more savings in practice. Similarly, electricity for the trucks could be used from purely renewable sources, which would reduce emissions even further. Moreover, the rail electricity mix is an average value from [28], which may vary over time and the train operating company.

## 5 Conclusion

This contribution highlights the potential of two decarbonization measures that are currently underrepresented in the Austrian industrial freight landscape: combined transportation and the use of advanced biofuels. It presents the environmental merits of utilizing a novel load carrier design enabling competitive combined road-rail transportation in the construction material supply chain. Therefore, the GHG emissions in an exemplary transport chain are quantified by using nine scenarios, comparing the utilization of different truck fuels and transshipment equipment. Results show that, compared to direct truck transportation, an emission reduction of 75% to 93% can be reached by using combined road-rail transportation. All scenarios using combined transportation reduce emissions compared to their direct transportation counterparts - except one. In this special scenario, trucks are powered by electricity and the additional Diesel-powered hub operations as well as the non-electrified section of rail transport exceed the lower energy consumption of electrified rail transportation. Nevertheless, up to

the point in time to which battery electric trucks can be utilized broadly, combined road-rail transportation provides a significant short-time emission reduction potential. After this point, hub operations and rail track electrification may play a crucial role in determining how beneficial combined road-rail transportation will be from the environmental perspective.

**Acknowledgments.** This work was accomplished with intensive support from Silo-Riedel GmbH, who provided details on the exemplary transport chain, Innofreight Solutions GmbH, who provided details on the CemTainer design, as well as Paul Rudolf GmbH, who provided the authors with exemplary data for HVO emission factors.

## Appendix

### Calculation Spreadsheet

The Excel spreadsheet for the calculation can be found online: <https://github.com/pmikla14/crrt-in-cmsc-ghg-quantification/>.

### Tables

**Table 2.** Scenario parameter variations

Scenario	Transshipment	Truck fuel
1a	None	Diesel B7
1b	None	HVO
1c	None	Electricity
2a	Reach stacker	Diesel B7
2b	Reach stacker	HVO
2c	Reach stacker	Electricity
3a	RMGC	Diesel B7
3b	RMGC	HVO
3c	RMGC	Electricity

**Table 3.** Transport chains with their respective transport chain elements and hub/transport operation categories according to [27]

Scenario	TCE	TOC/HOC		
		a	b	c
1	1	$TOC_{t,d}(B7)$	$TOC_{t,d}(HVO)$	$TOC_{t,d}(E)$
	2	$TOC_{t,d}(B7)$	$TOC_{t,d}(HVO)$	$TOC_{t,d}(E)$
2	1	$TOC_{r,c}$	$TOC_{r,c}$	$TOC_{r,c}$
	2	$HOC_{RS}$	$HOC_{RS}$	$HOC_{RS}$
	3	$TOC_{t,c}(B7)$	$TOC_{t,c}(HVO)$	$TOC_{t,c}(E)$
	4	$TOC_{t,c}(B7)$	$TOC_{t,c}(HVO)$	$TOC_{t,c}(E)$
	5	$HOC_{RS}$	$HOC_{RS}$	$HOC_{RS}$
	6	$TOC_{r,c}$	$TOC_{r,c}$	$TOC_{r,c}$
3	1	$TOC_{r,c}$	$TOC_{r,c}$	$TOC_{r,c}$
	2	$HOC_{RMGC}$	$HOC_{RMGC}$	$HOC_{RMGC}$
	3	$TOC_{t,c}(B7)$	$TOC_{t,c}(HVO)$	$TOC_{t,c}(E)$
	4	$TOC_{t,c}(B7)$	$TOC_{t,c}(HVO)$	$TOC_{t,c}(E)$
	5	$HOC_{RMGC}$	$HOC_{RMGC}$	$HOC_{RMGC}$
	6	$TOC_{r,c}$	$TOC_{r,c}$	$TOC_{r,c}$

**Table 4.** Different GHG emission intensities of electricity for Austria

Reference	Description	Value	Year
EEA 2022 *	Electricity generation	25.55 $gCO_{2e}/MJ$	2021
Scarlat et al. (2022)**	Electricity use	73.33 $gCO_{2e}/MJ$	2019
[28]	Electricity for railway	49.00 $gCO_{2e}/MJ$	–
[32]	Electricity for transportation	17.666 $gCO_{2e}/MJ$	2022

\* European Environmental Agency: Greenhouse gas emission intensity of electricity generation in Europe.

<https://www.eea.europa.eu/ims/greenhouse-gas-emission-intensity-of-1>

\*\* Scarlat, N., Prussi, M., Padella, M.: Quantification of the carbon intensity of electricity produced and used in europe. Applied Energy 305, 117901 (2022). DOI: 10.1016/j.apenergy.2021.117901

### Figures

The subplots of Fig. 2 are grouped by the truck fuel to ensure a comparison between truck transportation and combined transportation. In all scenarios, except 2c, emissions from combined transportation are lower than those of sole truck transportation. This is due to low emissions from battery electric trucks and high emissions from hub operations.

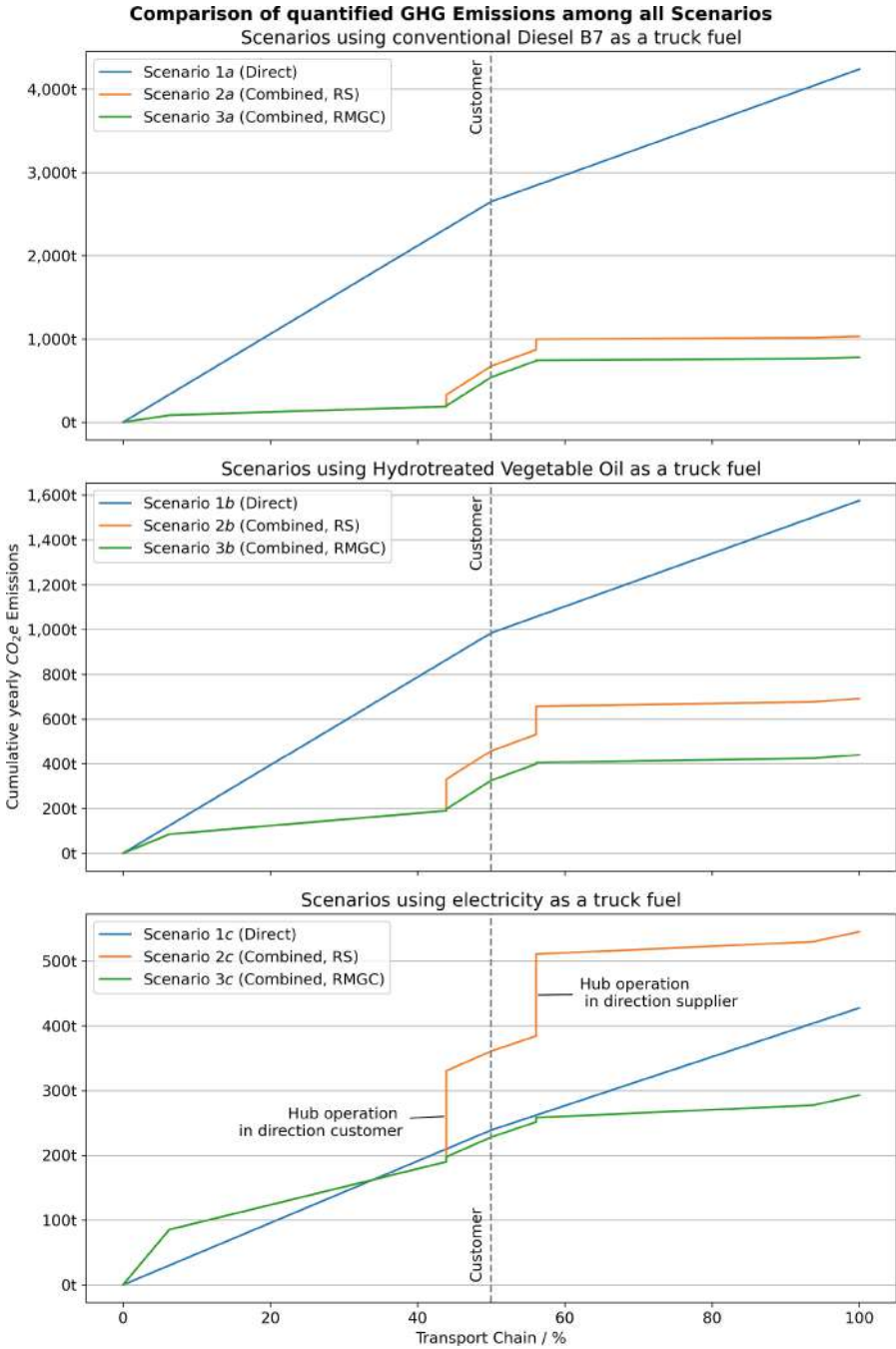

**Fig. 2.** Cumulative GHG emissions in the nine scenarios, grouped by the truck fuel

## References



1. Lee, H., et al.: Synthesis report of the IPCC sixth assessment report (2023). [https://report.ipcc.ch/ar6syrr/pdf/IPCC\\_AR6.SYR.SPM.pdf](https://report.ipcc.ch/ar6syrr/pdf/IPCC_AR6.SYR.SPM.pdf)
2. Dhakal, S., et al.: Emissions trends and drivers. In: IPCC (ed.) *Climate Change 2022: Mitigation of Climate Change*. Cambridge (2022)
3. Ritchie, H., Roser, M.: *CO<sub>2</sub> and greenhouse gas emissions*. Our World in Data (2020)
4. Jaramillo, P., et al.: Transport. In: IPCC (ed.) *Climate Change 2022: Mitigation of Climate Change*. Cambridge (2022)
5. Miklautsch, P., Woschank, M.: A framework of measures to mitigate greenhouse gas emissions in freight transport: systematic literature review from a manufacturer's perspective. *J. Clean. Prod.* **366**, 132883 (2022)
6. UIRR: *2021-22 UIRR Report: European Road-Rail Combined Transport* (2022). <https://www.uirr.com/uirr-report/>
7. Dluhoš, M., Pečený, L., Meško, P., Šulko, P.: The impact of delays of freight trains in JIT system on example one track line. In: *MATEC Web of Conferences*, vol. 134, p. 00011 (2017)
8. Wucherpfennig, D., Ehret, M., Schoberl, M., Malzacher, G., Bohm, M., Fottner, J.: Model-based systems engineering for the design of an intermodal high-speed freight train terminal. In: *2022 IEEE International Systems Conference (SysCon)*, pp. 1–8. IEEE (2022)
9. Zgonc, B., Tekavčič, M., Jakšič, M.: The impact of distance on mode choice in freight transport. *Eur. Transp. Res. Rev.* **11**(1), 1–18 (2019)
10. Rodrigue, J.P.: *The Geography of Transport Systems*, 5th edn. Routledge, Abingdon, Oxon, New York (2020)
11. Statistik Austria: *Verkehrsstatistik 2020* (2021). [https://www.statistik.at/wcm/idc/idcplg?IdcService=GET\\_NATIVE\\_FILE&RevisionSelectionMethod=LatestReleased&dDocName=127158](https://www.statistik.at/wcm/idc/idcplg?IdcService=GET_NATIVE_FILE&RevisionSelectionMethod=LatestReleased&dDocName=127158)
12. Liao, L., Yang, C., Quan, L.: Construction supply chain management: a systematic literature review and future development. *J. Clean. Prod.* **382**, 135230 (2023)
13. Hsu, P.Y., Aurisicchio, M., Angeloudis, P.: Risk-averse supply chain for modular construction projects. *Autom. Constr.* **106**, 102898 (2019)
14. Backes, J.G., Traverso, M.: Application of life cycle sustainability assessment in the construction sector: a systematic literature review. *Processes* **9**(7), 1248 (2021)
15. Ali, Y., Saad, T.B., Sabir, M., Muhammad, N., Salman, A., Zeb, K.: Integration of green supply chain management practices in construction supply chain of CPEC. *Manage. Environ. Qual.: Int. J.* **31**(1), 185–200 (2020)
16. Jourquin, B., Beuthe, M., Demilie, C.L.: Freight bundling network models: methodology and application. *Transp. Plan. Technol.* **23**(2), 157–177 (1999)
17. Guerlain, C., Renault, S., Ferrero, F.: Understanding construction logistics in urban areas and lowering its environmental impact: a focus on construction consolidation centres. *Sustainability* **11**(21), 6118 (2019)
18. Xella: How the transport of our building materials is becoming more sustainable (2022). <https://news.xella.com/csr/how-the-transport-of-our-building-materials-is-becoming-more-sustainable>
19. Crainic, T.G., Kim, K.H.: Chapter 8 intermodal transportation. In: *Transportation, Handbooks in Operations Research and Management Science*, vol. 14, pp. 467–537. Elsevier (2007)
20. Council of European Union: *Council directive 92/106/EEC* (1992)



21. Mogale, D.G., Kumar, M., Kumar, S.K., Tiwari, M.K.: Grain silo location-allocation problem with dwell time for optimization of food grain supply chain network. *Transp. Res. Part E: Logist. Transp. Rev.* **111**, 40–69 (2018)
22. Zsifkovits, H.E.: *Logistik, Reihe Grundwissen der Ökonomik*, vol. 3673. UVK-Verl.-Ges and UVK/Lucius, Konstanz and München (2013)
23. Kukulski, J., Lewczuk, K., Góra, I., Wasiak, M.: Methodological aspects of risk mapping in multimode transport systems. *Eksploracja Niezawodność – Maintenance Reliab.* **25**(1) (2023)
24. Ferrovie Udine Cividale: Cargo at societa ferrovie udine cividale srl (2018). [https://www.ferrovieudinecividale.it/wp-content/uploads/2018/12/FUC\\_folder-cargo-2015.pdf](https://www.ferrovieudinecividale.it/wp-content/uploads/2018/12/FUC_folder-cargo-2015.pdf)
25. CD Logistics: Types of containers (2023). <https://www.cdcarlogistics.cz/en/nase-sluzby/system-innofreight/types-containers>
26. InnoFreight: Chemietainer 20ft: In intermodal rail/road transport (2021). [https://www.innofreight.com/wp-content/uploads/2021/06/ChemieTainer\\_EN.pdf](https://www.innofreight.com/wp-content/uploads/2021/06/ChemieTainer_EN.pdf)
27. ISO/FDIS 14083: Greenhouse gases: Quantification and reporting of greenhouse gas emissions arising from transport chain operations (2023). <https://www.iso.org/standard/78864.html>
28. ETW: Environmental methodology and data: Update 2022 (2022). [https://www.ecotransit.org/wordpress/wp-content/uploads/20220908\\_Methodology\\_Report\\_Update\\_2022\\_Website.pdf](https://www.ecotransit.org/wordpress/wp-content/uploads/20220908_Methodology_Report_Update_2022_Website.pdf)
29. BMK: Biokraftstoffe im verkehrssektor 2021 (2021). <https://www.bmk.gv.at/themen/energie/publikationen/biokraftstoffbericht.html>
30. ÖNORM EN 16258: Methode zur berechnung und deklaration des energieverbrauchs und der treibhausgasemissionen bei transportdienstleistungen (güter- und personenverkehr) (2012)
31. European Union: Consolidated text: Directive (EU) 2018/2001 of the European parliament and of the council of 11 December 2018 on the promotion of the use of energy from renewable sources (recast) (text with EEA relevance)text with EEA relevance (2022). <https://eur-lex.europa.eu/legal-content/EN/TXT/?uri=CELEX:02018L2001-20220607>
32. UBA: Anrechnung (erneuerbarer) strom: gem. §11 kraftstoffverordnung (kvo) (2023). <https://www.umweltbundesamt.at/elna/anrechnung-erneuerbarer-strom>



# Embedding RFID Tags into Modular Textile Floor Coverings and Integration in BIM

Abduaziz Juraboev<sup>1</sup> , Sebastian Suess<sup>2</sup>, Rüdiger Kern<sup>1</sup>, and Joaquín Díaz<sup>1</sup> 

<sup>1</sup> Department of Architecture and Civil Engineering, University of Applied Sciences Mittelhessen, Giessen, Germany

abduaziz.juraboev@bau.thm.de

<sup>2</sup> Department of Mathematics, Natural Sciences and Informatics, University of Applied Sciences Mittelhessen, Giessen, Germany

**Abstract.** This paper investigates the embedding of Radio Frequency Identification (RFID) transponders in modular textile floor coverings and their integration into the Building Information Model (BIM). The aim of the research was to embed passive RFID tags into modular textile floor coverings (e.g. carpets) and to identify the suitable embedding methods for the RFID tags in order to verify the performance, especially the signal strength and reading performance of the tags.

The RFID reader has a Bluetooth interface and thus enables read IDs to be passed on to Bluetooth-enabled devices such as smartphones or tablets. As a novel approach, BIM models were wirelessly connected to physical building materials such as floor coverings by using RFID tags in a cross-platform application. Application areas include material tracking, warehouse inventory management, transport planning and real-time model-based indoor navigation systems. By embedding of RFID tags into the modular textile floor materials, the information associated with the materials can be more easily identified and retrieved throughout the lifecycle. These tags can be used for the information transfer of product data, e.g. properties that are stored in the product information system, instructions for cleaning and recycling of the materials.

**Keywords:** Textile Floor Covering · Radio Frequency Identification · Building Information Modeling · Navigation System For Blind And Visually Impaired

## 1 Introduction

### 1.1 Background and Problem Statement

An essential component for visually impaired people is independent mobility and information acquisition. Orientation is, almost everywhere, a prerequisite for independent participation in society. It is particularly problematic in unfamiliar buildings. Tactile guidance systems are increasingly used in outdoor areas, but usually only up to the building entrance. For indoor use, tactile aids (warning) are available in the form of knobs and strips made of plastic or stainless steel that can be attached to existing floor coverings. However, these guidance systems have not been widely used because they

tend to interfere with the design concept. Optical guidance systems can help a visually impaired person with orientation, while blind people can use haptic guidance systems. But these systems provide no information about the surroundings, only directional and potentially dangerous information.

In recent decades, the principles of accessibility and sustainability in construction have become increasingly important. The German Federal Ministry of the Interior's (BMI) guidelines for sustainable construction call for barrier-free accessibility and usability of buildings as a prerequisite for participation in social and professional activities at all stages of life. "The goal is to enable users to use the building without the need for assistance from others. In particular, it is important to enable people with disabilities to live independently and to participate fully in all areas of life" [1]. Therefore, the user-oriented planning and implementation of a barrier-free building for people with limited visual, auditory, cognitive or mobility abilities is one of the most important functional aspects of sustainability [2]. Accessibility is also required in the assessment systems for sustainable building [3], the certification system of the German Sustainable Building Council (DGNB) [4]. The Sustainable Building Assessment System (BNB) is applied to all newly planned or renovated buildings. Some of the BNB assessment criteria are assigned to fulfil the standard of accessibility and its functionality. The aim of the socio-cultural and functional quality requirements of the assessment system is to enable better accessibility and freedom of movement for all people in the built environment. In the future, the importance of accessibility will increase significantly due to demographic changes in the total population.

Integration of Radio Frequency Identification (RFID) technology in building materials (e.g. floor coverings) and Building Information Modeling (BIM) methodology in blind navigation systems has socio-cultural and economic aspects. Socio-cultural qualities include user safety, such as consideration of fire safety and accessibility, and an example of a construction-specific aspect is thermal comfort. According to the DGNB definition, the financial characteristics of buildings are determined by their life cycle costs and value retention.

The research on embedding RFID tags in modular floor coverings and their integration into BIM building models was methodically and practically investigated based on the following concrete and the feasible applications using the following questions:

- What is the current state of the art and research in the integration of RFID technologies in BIM?
- What are the advantages of integrating RFID tags in textile floor coverings?
- Can digital BIM models be linked to physical structures in real time using RFID technology as a digital twin, for example to set up a navigation and positioning system?

## 1.2 State of the Art

Tactile guidance systems for the blind are used in public buildings and infrastructure to help visually impaired people find their way in unfamiliar surroundings. These are usually floor guidance systems in which structural elements in the floor covering, known as tactile floor indicators, can be felt by blind and visually impaired people using white canes, thus enabling orientation. Other tactile guidance options for the visually impaired

include Braille signs, such as door and handrail signs. Acoustic signals, for example at traffic lights or bus stops, are also often used in practice. However, these guidance systems have the following disadvantage:

- They only guide the visually impaired and do not provide more detailed information about the surroundings,
- The guidance systems are not preferred indoors for aesthetic reasons and are therefore relatively rarely used, for example, to guide visually impaired people out of buildings,
- The guidance systems are not suitable for guiding visually impaired people out of a building quickly and accurately, e.g. in case of.

In addition to the widely used tactile guidance systems, there are a number of other guidance systems that provide alternative and/or additional orientation options for visually handicapped, mobility restricted and non-disabled people. In [5] several databases were searched using the keywords “visually impaired”, “blind”, and “indoor navigation”.

An overview of important other guidance systems beyond tactile guidance systems, all of which are electronically supported in various forms, but where location is determined in different ways, is given in Table 1 below.

**Table 1.** Positioning systems.

Positioning systems	Item description	Used in	Evaluation	Source
GPS (Global Positioning System)	Global Navigation Satellite System transmits radio signals to determine position	Out-door	<ul style="list-style-type: none"> <li>• For outdoor use only</li> <li>• Inaccurate positioning for indoor areas</li> </ul>	[6]
RFID (Radio-Frequency Identification)	RFID transponders use electromagnetic waves to transmit information to a reader	Out-door and indoor	<ul style="list-style-type: none"> <li>• Proven and reliable system</li> <li>• High accuracy in position finding</li> <li>• Maintenance-free when using passive tags, no battery exchange required</li> <li>• Can easily be used in indoor areas</li> <li>• Provides information via a database server</li> </ul>	[7]

*(continued)*

**Table 1.** (continued)

Positioning systems	Item description	Used in	Evaluation	Source
Beacons	At least three small transmitters (beacons) in a room send signals out via Bluetooth that are received by smartphones	Out-door and indoor	<ul style="list-style-type: none"> <li>• Inaccurate for more precise/accurate positioning</li> <li>• Requires regular battery replacement</li> <li>• In sensitive areas, such an active system emitting electromagnetic signals can be problematic</li> </ul>	[8]
Wi-Fi	Smartphones detect the characteristic pattern of electromagnetic radiation from Wi-Fi access points	Indoor	<ul style="list-style-type: none"> <li>• Inaccurate to provide more precise positioning</li> <li>• Requires complex calibration that must be repeated if the environment changes</li> </ul>	[9]
Ultra-wideband technology (UWB)	Radio technology that operates with high bandwidth and enables high accuracy in positioning	Out-door and indoor	<ul style="list-style-type: none"> <li>• Inaccurate to provide more precise positioning</li> <li>• Extensive calibration required</li> </ul>	[9]
Camera-based positioning	The image from camera is used to detect obstacles or, with a stored environmental model	Out-door and indoor	<ul style="list-style-type: none"> <li>• Difficult to handle for visually handicapped people</li> </ul>	[10]

Based on Table 1, an RFID-based guidance system proves to be a particularly suitable guidance system for the use case of precise orientation and information distribution. Within the scope of this study, the RFID transponders will be integrated into the textile floor coverings. The requirements for the selected system are based on the following specifications:

- High positioning accuracy, nearest centimetre recognition.
- Maintenance-free during the operational phase of buildings.
- Easy to use in indoors, practical.
- Reading of updatable information at points of interest.

Radio Frequency Identification (RFID) is an Auto-ID technology for transmitter-receiver systems that enables automatic and wireless identification and localisation of objects using radio waves [11]. The main function and mission of Auto-ID technology is to provide information about objects (people, animals, goods or merchandise). RFID systems expand traditional Auto-ID methods' functionalities and application possibilities and offer a high potential for increasing efficiency [12]. The use of RFID systems is offered in many variations. The range of RFID solutions is extensive. According to a study by the German Federal Office for Information Security, an RFID system is defined by the following three characteristics [12].

1. **Electronic identification:** The system allows objects to be uniquely identified by electronically stored data.
2. **Wireless data transmission:** Data can be read wirelessly via a radio frequency channel to identify the object.
3. **Send on call/request:** A tagged object sends its data only when a specific reader calls this operation. The reader reads the data from the transponder.

A Building Information Model (BIM) is a comprehensive digital representation of a building and infrastructure. It typically contains the three-dimensional geometry of the single elements of the building at a defined level of detail (LOD). It also includes non-physical objects, such as rooms and zones, and a hierarchical project structure. These objects are typically associated with a well-defined set of semantic information, such as the component type, materials, technical properties, and the relationships between the components and other physical or logical entities [13]. On the one hand, BIM is a process for creating, modifying, and managing such a digital building model using appropriate software tools. On the other hand, however, the term is also used to describe the use of the digital model throughout the lifecycle of the building.

The innovative approach of this work is to combine different technologies and methods for accessibility and inclusion of the visually impaired people by extending of the functionalities of building materials, using textile floor coverings.

## 2 Methodology

### 2.1 Concept

The objective of this work was to identify, on the basis of the test results, the RFID transponders (also known as “tags” – the actual data carriers) for integration into modular textile floor coverings. Taking these into account, the selection of the RFID tags was examined in detail according to the installation situation and the range of the building material. For the design and future model-based navigation system, BIM models were used to link the virtual world with a physical environment.

The integration of wireless technologies for connectivity into BIM systems can provide new opportunities for the development of BIM model-based positioning and navigation systems. A mobile application can be developed to incorporate physical structures into a BIM model with the help of RFID tags embedded in modular textile floor coverings. The concept was developed using the design thinking methods, which are well suited to solving complex problems (Fig. 1). The aim of the method is to solve

problems based on the needs of the users, as well as to show a solution path for a specific problem. At the centre of all considerations is the human being.

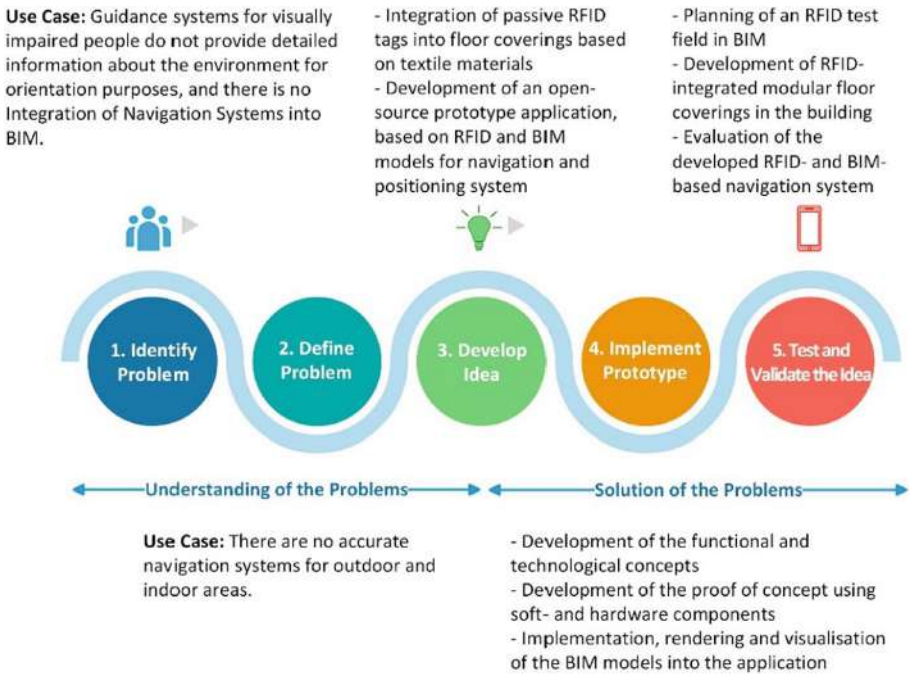
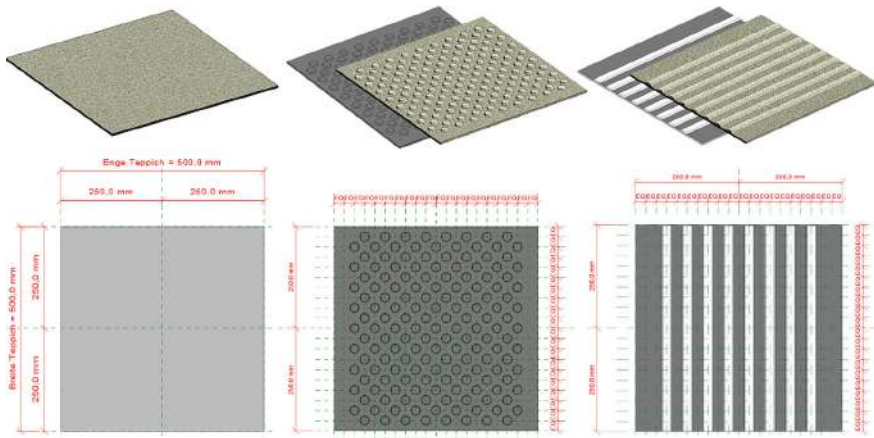

**Fig. 1.** Ideation generation using the design thinking process.

Within the framework of this research project, the requirements for RFID technology were developed to assess the usability of a textile guidance system. The technical principles for the integration of RFID tags (type, quantity, placement, integration) in textile modular floor coverings were developed.

## 2.2 Implementation

The practical part of this work focused on the creation of loadable BIM objects, the integration of RFID tags in BIM models and in physical textile materials (Fig. 2). The modular, textile floor coverings in various sizes in the form of knobs, strips and standard elements for indoor spaces were developed as a building element family (BIM objects or also called Revit content). The BIM modelling guideline defines the model creation, as well as the structure and requirements for the models and their structural components. Revit Autodesk was used for the planning and design of the BIM model. The geometry of the loadable component is max. 500 mm × 500 mm and was provided with parameters such as dimensions, material, manufacturer data and RFID tag unique ID (UID).



**Fig. 2.** Modelling of a loadable BIM object for textile flooring with knobs and stripes.

Several passive RFID inlay UHF (Ultra High Frequency at 860–960 MHz) tags with EPC Global Class 1 Gen 2 ISO/IEC 18000-6C standard are inserted into each modular textile floor covering at a distance of 5–7 cm (Fig. 3). The dimensions of the inlay tags are in the millimetre range (<1 mm). There are several ways of inserting them: gluing to the back side of the carpet, placement on the side of the carpet, sewing them in the carpet etc. It is important that the inlay tags are resistant to interior influences such as protection towards water, moisture, etc.

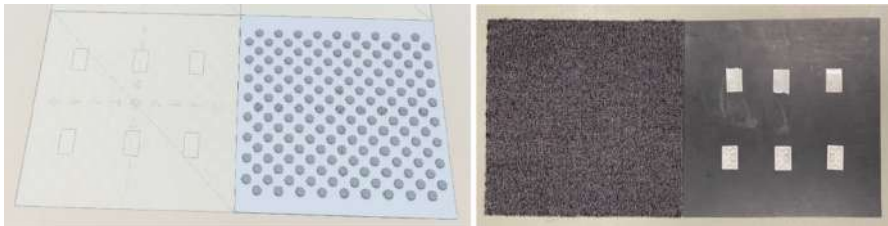

**Fig. 3.** Embedding RFID tags in a modular textile carpet tile.

Within the scope of the tests, the load test of the RFID tags in combination with the textile floor covering was carried out. The Inlay RFID met the following requirements:

- Chair castor test (EN 985): mechanical stress
- Pedal wheel test (EN ISO 12951): mechanical stress
- Dimensional change (ISO 2551): Influence of heat and humidity

Figure 4 shows RFID smart labels that are very thin, self-adhesive and consist of different chip types for all frequency ranges (LF, HF, UHF). In this trial, the UHF labels were placed under the carpet tile structure due to the extended reading range.



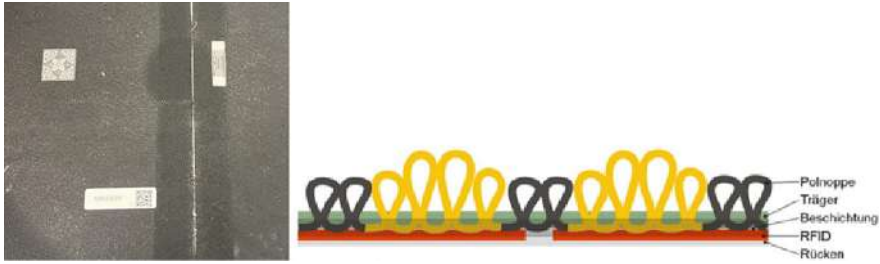
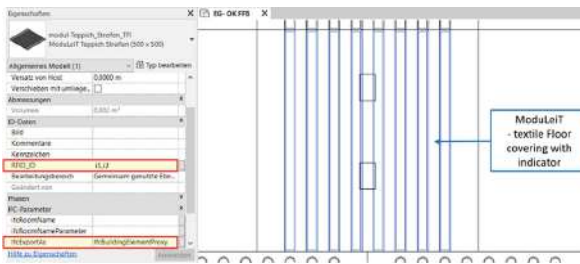

**Fig. 4.** Identification and Integration of RFID Inlay in Textile Materials (ModuLeiT).

### 3 Embedding Passive RFID Tags into Modular Carpets

Ultra High Frequency (UHF) RFID tags were selected, because, according to the results of a research report [14], they are suitable for integration into different materials based on the following criteria:

- Robustness of the UHF RFID tag
- Water resistance (protection against water)
- Protection from foreign objects
- Thickness of the RFID tag



**Fig. 5.** RFID tags integrated into BIM model for textile floor coverings.

Currently, the reading range of RFID tags embedded in textile floor coverings is being tested using a blind cane developed by the Papeinmeier GmbH. Initial test results show that the wet inlay tags are well suited to the carpets due to the thinness of the tag. For the selection of tags, the circular polarization, protection class IP68, according to ISO 18000-6C and the underground construction of the textile material are important. The UID of RFID tags can be integrated into the BIM planning software, e.g. as shown in Fig. 5, Autodesk Revit using parameters. To use the BIM models in practice, it is necessary to import the BIM models into an application to be developed.

## 4 Conclusion and Outlook

The research results show that by integrating RFID tags, as BIM objects, into building elements, the physical objects can be linked to digital BIM models using “RFID tag” component families, using a serial number to specific coordinates. There was no obvious damage to the tags, and they could be identified by scanning. The read and receive range of the commercially available serial RFID UHF inlay tags is not a problem. The prototype of the developed application for connecting/linking BIM models with RFID technology was published in the conference proceedings [14] of the Forum Bauinformatik in Munich in 2022. Future work will include the development of an application that provides the user with the information integrated in the BIM model.

**Acknowledgements.** The authors of this paper gratefully acknowledge the funding of the research project “Development of a design guideline for modular, haptic and optical floor indicators for guidance systems for the blind and RFID-based indoor navigation systems based on textile floor coverings (ModuLeiT)” in cooperation with TFI - Institut für Bodensysteme an der RWTH Aachen e.V..

## References

1. Bundesministerium für Verkehr and Bau und Stadtentwicklung, Bewertungssystem Nachhaltiges Bauen (BNB) Büro- und Verwaltungsgebäude: 3.2.1 Barrierefreiheit. [https://www.bnb-nachhaltigesbauen.de/fileadmin/steckbriefe/verwaltungsgebäude/neubau/v\\_2015/BNB\\_BN2015\\_321.pdf](https://www.bnb-nachhaltigesbauen.de/fileadmin/steckbriefe/verwaltungsgebäude/neubau/v_2015/BNB_BN2015_321.pdf)
2. Bundesministerium der Justiz und für Verbraucherschutz, Gesetz zur Gleichstellung von Menschen mit Behinderungen: BGG-Behindertengleichstellungsgesetz, 27 April 2002
3. Bundesministerium für Verkehr and Bau und Stadtentwicklung, Bewertungssystem Nachhaltiges Bauen (BNB) Büro- und Verwaltungsgebäude: 3.2.1 Barrierefreiheit, Bundesministerium für Verkehr, pp. 1–5 (2015)
4. DGNB GmbH, DGNB System: Kriterienkatalog Gebäude Neubau, in, pp. 1–648
5. Plikynas, D., Žvironas, A., Budrionis, A., Gudauskis, M.: Indoor navigation systems for visually impaired persons: mapping the features of existing technologies to user needs. *Sensors* **20**, 636 (2020). <https://doi.org/10.3390/s20030636>
6. Kirkpatrick, S.: Loadstone GPS - Home. Loadstone GPS for IOS (2020). <http://www.loadstone-gps.com/>. Accessed 04 Dec 2021
7. Galler, F.: Localization of Passive UHF RFID Tags, Diss. TU Wien (2019)
8. Navigine, Indoor Navigation für Museen (2022). <https://navigine.com/de/industries/museums/>
9. Jäger, M., Süß, S., Becker, N.: Multi-scheme smartphone localization with auto-adaptive dead reckoning. *Int. J. Adv. Syst. Meas.* **8**(3 & 4) (2015). issn1942-261x
10. Liu, Y., Stiles, N.R., Meister, M.: Augmented reality powers a cognitive assistant for the blind, Pasadena, United States, 27 November 2018. <https://elifesciences.org/articles/37841>. Accessed 21 Aug 2020
11. Finkenzeller, K.: RFID-Handbuch: Grundlagen und praktische Anwendungen von Transpondern, kontaktlosen Chipkarten und NFC, 7th edn. München (2015)
12. Bundesamt für Sicherheit in der Informationstechnik, Risiken und Chancen des Einsatzes von RFID-Systemen. [https://www.bsi.bund.de/SharedDocs/Downloads/DE/BSI/ElekAusweise/RFID/RIKCHA\\_barrierefrei\\_pdf.pdf?\\_\\_blob=publicationFile&v=2](https://www.bsi.bund.de/SharedDocs/Downloads/DE/BSI/ElekAusweise/RFID/RIKCHA_barrierefrei_pdf.pdf?__blob=publicationFile&v=2)

13. Borrmann, A., König, M., Koch, C., Beetz, J.: Building Information Modeling: Technologische Grundlagen und industrielle Praxis, 2nd edn. Springer Fachmedien Wiesbaden, Wiesbaden (2021). <https://doi.org/10.1007/978-3-658-33361-4>
14. Juraboev, A., Díaz, J., Kern, R.: Implementierung des Internet of Things (IoT) auf Basis von Radio-Frequency Identification (RFID) in das Building Information Modeling (BIM). <https://mediatum.ub.tum.de/doc/1688408/aoo9d5a4duuvb1utk9gmai1rr.Juraboev%202022.pdf>

# **Construction Robotics**



# Status Quo of Construction Robotics: Potentials, Applications and Challenges

Christian Richter<sup>1</sup> , Jan Kortmann<sup>2</sup> , Janik Mischke<sup>2</sup> , Frank Will<sup>1</sup> ,  
and Jens Otto<sup>2</sup> 

<sup>1</sup> Chair of Construction Machinery, Technische Universität Dresden, 01062 Dresden, Germany  
baumaschinen@tu-dresden.de

<sup>2</sup> Institute of Construction Management, Technische Universität Dresden, 01062 Dresden,  
Germany

baubetrieb@mailbox.tu-dresden.de

**Abstract.** Construction robots aim to automate manual construction processes and to relieve construction workers from physically difficult and monotonous tasks. The field of construction robotics is currently very dynamic, which is reflected in a large number of different systems and prototypes that have been developed in recent years. There are often large differences between the individual robotic systems in terms of economic efficiency, practicality and conformity with applicable standards and laws. The objective of this paper is to identify suitable use cases for the development and deployment of construction robots, to analyze the current state of the art and to clarify the legal framework under which the deployment of highly automated and autonomous systems on construction sites is possible. Based on an analysis and evaluation of industry-specific work processes that are carried out in the construction and expansion of buildings, use cases with a particularly high automation potential are selected. The evaluation of the processes takes into account various aspects, including the complexity of the processes, the potential hazards caused by them and the cost-effectiveness of automation. Furthermore, an overview of technological readiness level as well as the level of automation of current robotic systems is given. Finally, applicable standards, regulations and laws are presented and the conditions under which construction robotics systems can be used on construction sites are explained.

**Keywords:** Construction Robotics · Automation · Regulatory situation

## 1 Introduction

The construction industry is an essential part of modern society and an important economic sector across the world. In most countries the spending in construction represents between 9% and 15% of GDP [1]. However, the industry is facing significant challenges, such as labor shortages, increasing costs and inefficiencies. While productivity has improved steadily in many industrial sectors over the last decades, the productivity of the construction industry has seen little to no improvement. To address the

mentioned challenges, construction robotics has emerged as a promising solution. Construction robotics refers to the use of robots and automation technologies to perform tasks traditionally carried out by human workers on construction sites.

Automation and robotic systems have demonstrated their effectiveness in reducing labor costs, improving productivity, and enhancing quality in various industries [2]. Additionally, these technologies have the potential to decrease injuries and alleviate workers from performing hazardous tasks [3]. According to [4], traditional construction techniques reached their limits, and the adoption of automation and robotics technologies holds promise in overcoming the productivity challenges faced by the construction industry.

The first robotic systems for construction were developed in the early 1970s coincided with the rise of automation in other industries such as the automotive sector. However, the adoption of robotics technology into the construction industry has been sluggish for a long time. In recent years, construction robotics has undergone a renewed surge based on new developments in sensing and communication technologies as well as software and artificial intelligence. More and more companies and building owners are now considering the use of construction robots. One of these is the Bau- und Liegenschaftsbetrieb Nordrhein-Westfalen (BLB-NRW), which manages, plans, builds and exploits real estate in Germany. In preparation for the timely use of such systems, the BLB-NRW commissioned a study on the topic of construction robotics, which was carried out by the GWT-TUD GmbH and Technische Universität Dresden [5].

The following article provides a brief overview of the contents and results of this study. On the one hand, the focus is on the identification of construction processes that are particularly suitable for the use of construction robotics, and on the other hand, the current state of the art and the legal framework conditions are analysed.

## 2 Analysis of Construction Processes

The starting point for the analysis of automated construction processes is the identification of suitable work processes whose automation or partial automation can contribute to the overall objective of increasing productivity and reducing costs. As a first step for this analysis, typical work processes were divided into the sections of building construction and civil engineering. In accordance with a further delimitation, the analysis was carried out exclusively on the sections of building construction. In detail, the trades were arranged in a classification according to the GAEB (Gemeinsamer Ausschuss Elektronik im Bauwesen) and the VOB/C [6]. In the final step of the breakdown, the work processes, which are typically carried out in the form of manual work on the construction site, are defined.

The aim of this study is to identify construction processes with a high automation potential. The work processes, such as “cutting masonry bricks” or “demolish masonry bricks”, were evaluated by the authors using a catalogue of criteria to identify processes that are suitable for robotic systems. Evaluation criteria were defined for this purpose. Common evaluation criteria for the assessment of building processes can primarily be characterized by the adherence to costs, deadlines and quality [7]. In order to assess the automation potential, these criteria were adapted and supplemented by other influencing

components. The study also focuses on the complexity of work processes and the social aspect of a potential shortage of skilled workers or production capacity. The evaluation of work processes is based on the following criteria: Is the work process a process with:

1. high hazard potential?
2. physically heavy work?
3. high complexity?
4. frequently repetitive sub-processes?
5. imminent shortage of skilled workers or production capacity?
6. economically/ecologically high potential for automation?

The assessment shall be based on scores in the range of zero to two, reflecting the degree of achievement of the criterion. The score of two indicates that the criterion is fully met. On the other hand, a score of zero indicates that the criterion is not met. With the existence of the individual work processes per trade, the evaluation criteria, the weighting of the criteria and the evaluation scaling, the processes could be evaluated in terms of automation potential. From this, promising processes could be identified. The target value is the highest possible sum of the evaluations across all six criteria (maximum value = twelve). The assessment does not take into account the idea that the current work processes on the construction site could be completely rethought when using robotic systems. This applies, for example, to the consideration that the planning and execution of the processes should be coordinated with the requirements of robotics (high repetition rate, standardization, serial construction, construction without interruptions 24/7). For this point, further potentials arise, which need to be considered more closely in the future. The evaluation of the individual work processes results in the 15 most promising robotics applications on construction sites (Fig. 1).

trade	performance range	work process	assessment according to criteria						
			Σ	[1]	[2]	[3]	[4]	[5]	[6]
sealing work	application of seals to components	apply seals on roofs, balconies and loggias	11	2	1	2	2	2	2
roofing work	application of roof coverings	cutting roof coverings	11	2	2	2	1	2	2
plastering and stucco	application of plaster	apply plaster inside and outside	11	1	2	2	2	2	2
tile work	installation of ceramic tiles or slabs	laying ceramic tiles or slabs	12	2	2	2	2	2	2
		cutting ceramic tiles or slabs	11	2	1	2	2	2	2
parquet work	installation of parquet or wood pavings	laying parquet or wood pavings	12	2	2	2	2	2	2
		cutting parquet or wood pavings	11	2	1	2	2	2	2
		make recesses, install profiles	11	2	1	2	2	2	2
flooring work	installation of floor coverings	laying floor coverings	11	2	2	1	2	2	2
remediation of pollutants	remediation of pollutants on contaminated components and technical installations	remove contaminated surfaces (e. g. lightly bonded asbestos)	11	2	2	1	2	2	2
cross-departmental work processes	frequently recurring work processes	chiseling	11	2	2	1	2	2	2
		milling	11	2	2	1	2	2	2
		drilling	11	2	2	1	2	2	2
		mounting dowels	11	2	2	1	2	2	2
		transporting material	11	2	2	1	2	2	2

Fig. 1. 15 most promising application scenarios for robotics on construction sites

### 3 State of the Art in Construction Robotics

The Robotic Industries Association defines the term *robot* as follows: “A robot is a reprogrammable, multifunctional manipulator designed to move material, parts, tools or specialized devices through variable programmed motions for the performance of a variety of tasks”. Many systems commonly referred to as construction robots do not meet this definition. One of the main reasons for this is that most of the systems are designed for a specific construction process and therefore cannot be used for other tasks, e.g. robots for drilling, painting or marking.

Therefore, the aim of the study was not to search only for systems which explicitly fit the definition of a robot. Instead, the research conducted all technical solutions, that are in some way novel or unconventional and that have the fundamental ability for automation respectively are already working autonomously. This was limited to systems that are used on the construction site, i.e. automated pre-fabrication was not considered. Furthermore, only solutions that can be assigned to the areas of building construction, extension and deconstruction were examined. Civil engineering as well as road construction were not taken into account. A total of 70 technical solutions were researched. Figure 2 shows the number of systems by trade and construction task.

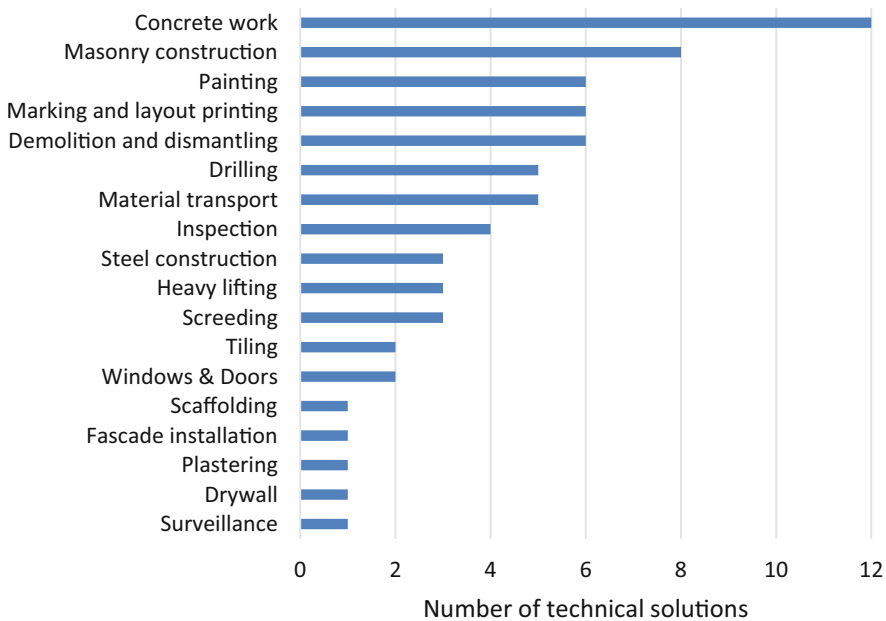

**Fig. 2.** Number of technical solutions by trade and construction task

In addition to general information such as name and manufacturer, each system was assigned an automation level and a technological readiness level. The automation level (AL) reflects the degree of automation while technology readiness level (TRL) is an established scale for assessing the development status of new technologies or systems.



A common classification for AL comes from the automotive industry, which defines a total of 6 levels (level 0 to 5) of automated driving in the SAE J3016 standard. An adaptation of these 6 levels to the industrial sector of construction machinery is shown in Table 1 [8]. Technology readiness level provides information on how far developed or how market-ready a technology or system is on a scale of 1 to 9. The assignment of AL and TRL to the individual systems was based on the available information and is partly subjective.

**Table 1.** Automation levels for construction machinery.

Automation Level	Designation	Description
0	No Automation	The operator controls the machine independently without further, actively supporting systems. This includes remote control systems
1	Assistance System	The operator controls the machine independently and is supported by displays. The data required for this is obtained from monitoring the machine using sensors and evaluation algorithms. The algorithms do not actively intervene in the machine control
2	Partial Automation	One or more axes are automatically moved simultaneously for individual sub-tasks. The operator must actively shape the work process
3	Conditional Automation	The automation system carries out work tasks independently, recognizes malfunctions, but does not make any decisions of its own. The operator must actively intervene
4	High Automation	The automation system carries out work tasks independently, recognizes malfunctions and makes its own decisions. The operator can actively intervene, for example via remote control
5	Full Automation	The automation system performs the same dynamic task performed by a human operator, under all environmental conditions, including the ability to automatically bring the machine into a minimal risk state in the event of a critical equipment or system failure or other emergency event

Figure 3 shows at which state of development the individual systems are. The size of the different bubbles indicates the number of technical solutions with the corresponding combination of AL and TRL. It can be seen that there are currently many systems under development that are aiming for automation level 3. Based on the current TRL, in the

opinion if the authors most of these systems will reach market maturity within the next 5 years.

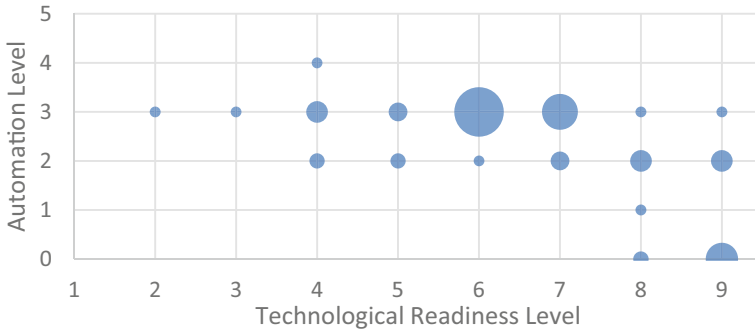

**Fig. 3.** Automation Level of the individual systems over Technological Readiness Level. Size of the bubble indicates the number of systems with corresponding AL and TRL.

## 4 Regulatory Situation with Automated Construction Processes

In dealing with automated production processes on construction sites, various aspects of occupational health and safety laws have to be taken into account. However, according to the current state of the art, automated construction processes are not yet established. For this reason, the legislator does not yet have specific occupational health and safety regulations concerning the handling of robotics systems on construction sites. Therefore, it is only necessary to take into account the general principles of occupational health and safety on construction sites, which apply mainly to the industry. Nevertheless, the existing legal basis provide sufficient evidence for the classification of automated construction processes within the scope of occupational health and safety on construction sites. In the following, the most important regulations of occupational health and safety under German law are considered.

The general rule is that the contractor must ensure the safety of his employees during work on the construction site. This includes the identification of hazards and the establishment of appropriate safety measures (see Sect. 5 (1) Baustellenverordnung in conjunction with Sect. 3 Arbeitsstättenverordnung). This also includes the handling of work equipment (see Sect. 1 Arbeitsstättenverordnung), which includes robotics systems. In order to be able to establish suitable protective measures, application-specific risk assessments have to be carried out for the respective robotic system. Based on this risk assessment, safety measures must be laid down and the workers concerned must be instructed. Furthermore, it should be noted that the client is obliged to coordinate the occupational and health protection of several companies operating on construction sites (see Sect. 3 Baustellenverordnung). Here it is necessary to consider automated construction methods in the considerations of the safety and health protection plan and the subsequent implementation and enforcement of the established safety measures.

In addition to the statutory requirements for occupational safety, statutory and normative requirements for operational safety govern the safety-relevant design of robotic systems. Manufacturers are obliged to offer only products on the market which do not pose a risk in the context of proper use (see Sect. 3 (1) 9. Produktsicherheitsgesetz). These legal provisions are further defined by standards. Care should be taken to ensure that only robotic systems are used which are designed according to the relevant standards. If robotic systems are designed according to the relevant standards, it can be assumed that they correspond to the current state of the art and are suitable for the intended use.

In principle, the same requirements apply to the use of robots on construction sites as for robots in stationary industry. Therefore, the entire operating area of the robot with a high-risk potential must be secured and monitored by protective devices. Due to the smaller operating area, this is easier to implement for stationary devices than for mobile devices operating in a larger area. In particular, fixed barriers, such as stable (construction) fences, can be considered as protective devices. Alternatively, the robots must have built-in sensor-assisted protection devices that detect hazards independently and stop or navigate the machine (e.g. in the presence of persons in the vicinity of the operating room). However, the sensor-assisted protection devices, such as photoelectric sensors or safety mats, must be suitable for use on construction sites. This is because of the high emissions of dust, noise and vibration, which are typical for construction sites. These emissions can have a major impact on the functioning of such systems. In addition, according to the standard, protective devices may be omitted if the entire robot including the workpiece falls below a maximum movement speed. This speed shall be determined based on a risk assessment in the individual case. Because there are no standardized requirements for this, guidance may be provided by standards which set limit values in a similar context. For robots, these are at a maximum of 250 mm/s [9]. However, this regulation needs a great awareness in dealing with robots and should only be used as a last resort. Irrespective of this, protective devices may also be omitted if the entire work area is monitored by personnel (e.g. by a separate supervisor). For the sake of completeness, reference should be made to the other known regulations on occupational health and safety in the handling of equipment (emergency shut-off switches, periodic inspection of equipment, training of staff, etc.). However, these are not dealt with separately here.

As far as clients are concerned, a risk assessment for automated production systems, if they are to be used, must be carried out during the planning phase and the resulting safety measures must be taken into account. This means that appropriate safety measures must already be included in the planning and tendering of the construction phase. Furthermore, during construction, care must be taken to ensure that the planned safety measures are implemented, checked and, if necessary, adapted. As these are mostly low-tested technologies, special attention needs to be paid to the implementation and, in particular, to the control of safety measures in construction robotics. In addition, it should be noted that only robotic systems are used which are also suitable for the specific application and that exclusively trained personnel supervise these.

## 5 Conclusion

It was shown that there are a large number of construction processes from different trades that have a high potential for automation. Comparing the identified construction processes with a high automation potential to the current state of the art shows that for some processes there are already many promising technical solutions - but for others there are none at all. For example, there are currently no systems for flooring, roofing or sealing. Furthermore, the analysis of technical developments has shown that many systems are aiming for conditional automation and are expected to be ready for the market within the next 5 years. Technical solutions with an automation level of 4 or 5, which is necessary for construction sites without human workers are not yet in sight. With regard to the use of automated construction methods, there is still a need for clarification on behalf of the occupational health and safety. The current regulations are sufficient for the test-based use of automated construction methods, but in order to establish construction robotics, specifications regarding occupational health and safety are imperative.



**Acknowledgements.** The results presented in this paper are based on a study by GWT-TUD GmbH (project number: 15414/210659, duration: 01.09.2022 to 31.12.2022). This study was commissioned and financed by the Bau- und Liegenschaftsbetrieb Nordrhein-Westfalen.

## References

1. Oesterreich, T.D., Teuteberg, F.: Understanding the implications of digitization and automation in the context of industry 4.0: a triangulation approach and elements of a research agenda for the construction industry. *Comput. Ind.* **83**, 121–139 (2016). <https://doi.org/10.1016/J.COM.PIND.2016.09.006>
2. Huang, P.Y., Sakurai, M.: Factory automation: the Japanese experience. *IEEE Trans. Eng. Manag.* **37**(2), 102–108 (1990). <https://doi.org/10.1109/17.53712>
3. Castro-Lacouture, D.: Construction Automation. In: Nof, S. (eds.) *Springer Handbook of Automation*, pp. 1063–1078. Springer, Berlin, Heidelberg (2009). [https://doi.org/10.1007/978-3-540-78831-7\\_61](https://doi.org/10.1007/978-3-540-78831-7_61)
4. Alwasel, A., Elrayes, K., Abdel-Rahmen, E., Haas, C.: Reducing shoulder injuries among construction workers. In: *ISARC Proceedings of the International Symposium on Automation and Robotics in Construction*, pp. 1–5 (2012)
5. Will, F., Richter, C., Otto, J., Kortmann, J.: Beratungsleistungen zur Verwendung praxisorientierter, marktverfügbarer Robotik in Bauvorhaben des Bau- und Liegenschaftsbetriebes NRW. Studie im Auftrag des Bau- und Liegenschaftsbetriebes Nordrhein-Westfalen (2023). <https://doi.org/10.25368/2023.24>
6. Deutsches Institut für Normung: VOB Vergabe- und Vertragsordnung für Bauleistungen - Teil C: Allgemeine Technische Vertragsbedingungen für Bauleistungen (ATV) - Allgemeine Regelungen für Bauarbeiten jeder Art (2019)
7. Berner, F., Kochendörfer, B., Schach, R., Jünger, H.C., Otto, J.: *Grundlagen der Baubetriebsslehre 2 – Baubetriebsplanung*, no. 3. Auflage. Springer Vieweg, Wiesbaden (2022). <https://doi.org/10.1007/978-3-658-03227-2>
8. Uhlmann, J., Beck, B., Fischer, E., Weber, J., Richter, C., Will, F.: Automatisierung von hydraulisch angetriebenen Erdbewegungsmaschinen – Teil 1: Stand der Technik. *Mobile Maschinen* **5**(2019), 24–33 (2019)
9. DIN EN ISO 11161 (2010) Punkt 8.6.2, Sicherheit von Maschinen – Integrierte Fertigungssysteme – Grundlegende Anforderungen, 2010-10. Beuth, Berlin



# Levels of Digitalization for Construction Machinery on the Connected and Automated Construction Site

Volker Waurich<sup>1</sup> , Benjamin Beck<sup>2</sup>, Jürgen Weber<sup>2</sup>, and Frank Will<sup>1</sup> 

<sup>1</sup> Chair of Construction Machinery, TU-Dresden, Dresden, Germany  
volker.waurich@tu-dresden.de

<sup>2</sup> Chair of Fluid-Mechatronic Systems, TU-Dresden, Dresden, Germany  
benjamin.beck@tu-dresden.de

**Abstract.** Digitalization and automation are among the most important development trends in the construction machinery industry. Despite the many individual solutions in these areas, the efficient operation of highly automated construction machines on the basis of mixed fleets requires a holistic view of the construction eco system. In this paper, the different levels of digital communication interfaces are classified in a structured manner and transferred to the current state of the art for construction machines. Relevant communication standards and protocols are presented. In order to address the requirements for connected and automated construction machines, two communication standards are presented that have been developed and validated in the joint research project Bauen4.0.

**Keywords:** Construction Machinery · Communication Architecture · Connectivity · OPC-UA · ISOBUS

## 1 Introduction

According to [1], *Digitalization is the use of digital technologies to change a business model and provide new revenue and value-producing opportunities; it is the process of moving to a digital business.* Due to the shortage of skilled workers in the construction business and the ongoing need for infrastructure and residential buildings, any means to increase productivity and leverage unused potentials are of great importance, including digitalization. Relevant means to tackle this target in the field of construction are e.g. assistance systems and automation, fleet management and inventory tracking, automated surveying and inspection, model based-workflows and BIM (building information modeling) [2, 3]. All of these technologies rely on the availability of digital data in formalized format, a specified interface to exchange the data, the physical data transmission and an overall system architecture to process and relay the data. Specifications of data models and transmission protocols are a crucial part for the comprehensive and scalable enforcement of digitalized technologies and there is a variety of both proprietary and open solutions for the challenges of connectivity in the field of construction machinery. In the following sections, a structural overview of relevant data and communication standards in the field of construction machinery is given.

## 2 The Automation Pyramid

In IEC 62264 respectively DIN EN 62264-1, a functional hierarchy for IT-systems in production control is described by 5 levels. This hierarchy is often called the automation pyramid. It is a structure to distinguish between different functions inside a production system. In the context of this paper, it will be used to describe data interfaces between and among the levels.

- Level 4 - functions of the business-related activities to run a production operation
- Level 3 - functions for managing the workflows to produce the desired end product
- Level 2 - functions to monitor and control the physical processes
- Level 1 - functions for sensing and influencing the physical processes
- Level 0 - the actual physical production process

While this structure is general, its implementation and the technologies applied might differ in different industries. In this paper, the focus is on construction machines, especially earth-moving machines. The following table shows some exemplary functions which can be assigned to the levels (Table 1):

**Table 1.** Levels of the automation pyramid with functions for earth-moving machinery

level	example function
4	fleet management and disposition, inventory tracking, logistic management
3	site-execution system, control systems in automated mines or container handling
2	3d-machine control system, tool management system, automation system (auto-digging, auto-grading), wheel loader scale, collision avoidance system, 3d-scanning
1	hydraulically operated equipment and tools, sensors for machine data (engine, hydraulics, process parameters)
0	digging, compacting, lifting, grading, transporting

## 3 Levels of Digitalization

In the following, all levels of digitalization are discussed and suitable technologies for the area of construction machines are presented. Whereas the first 3 levels make use of wired Bus-technologies, level 3 and 4 are dependent on radio communication and long-distance transmission which is implemented via IP-based protocols and web technologies.

### 3.1 Level 0: Process Level

As construction machines are concerned, the physical working process (digging, compacting, etc.) is not dependent on digital information exchange. There are rarely any use-cases for construction machines which rely on digital information on the process level, like RFID-Tags to identify certain assets (e.g. container logistics).

### 3.2 Level 1: Device Level

Digital connectivity on the machine level has been established for decades and besides digital and analog I/O, the CAN-Bus (Controller Area Network) is the state-of-the-art communication technology in construction machinery. CAN-Bus is used to connect several ECUs (electronic control unit) with low cabling effort (use of Bus-topology) and robust transmission (due to twisted pair cables and symmetrical transmission). There are some standardized high-level protocols based on CAN, such as SAE J1939 for diagnostic application especially for the engine, CANopen for industrial automation and sensor integration, ISO11783 (ISOBUS) for agricultural machines or the FMS-Standard for telematic data for trucks and other commercial vehicles. Although these standards are mature and commonly used in their domains, most OEMs of construction machines are utilizing their own, proprietary protocols and there is no uniform, open CAN-interface in construction equipment. Some efforts are taken by the VDMA-working group Machines in Construction 4.0, to establish a uniform CAN-protocol for the communication between excavators and attachments [4].

### 3.3 Level 2: Monitoring and Control Level

A widely used function for process monitoring in earth-moving machinery is the 3D-machine control system, that allows the monitoring of machine movement with reference to a digital design model. Most of these systems feature proprietary protocols to connect sensors (inclination, IMUs, rotary encoders) with a GNSS-System, Display and control-system. Other assistance functions such as wheel-loader and excavator weighing systems or tool-management systems do not offer any accessible interface except the GUI (graphical user interface) on a custom display. Integration of custom GUIs such as the Virtual Terminal from the agricultural domain (ISO 11783) are not applied in construction equipment industry so far.

So called Collision Warning and Avoidance Systems (CxS) are assistance systems that could be used more frequently in the future. Driven by the mining industry, interoperable communication standards for integrating CxS with construction machines are subject to development. In ISO/TS 21815-2 a high-level CAN-protocol based on J1939 is proposed for CxS. Besides communication of general machine data, the CxS is capable to call collision avoidance actions that interfere with the operation of the machine such as “slow down” or “controlled stop”.

Due to the evolution of 3D-sensing technologies, new requirements to data rate and data processing evolve. 3D-Sensing technologies such as stereo-cameras, time-of-flight cameras and LiDAR require Gigabit-Ethernet communication and performant computing power to process raw output data. Protocols used are manifold, ranging from most of the time proprietary UDP and TCP/IP transmission to middleware standards such as ROS, ROS2(DDS) or protobuf. Applications in the construction domain using alternatives to Ethernet such as CAN-XL are unknown to the author.

### 3.4 Level 3: Manufacturing Operations and Management

In industrial automation, the Manufacturing Execution System (MES) is the central information hub to control an entire production site. MES with task-management,

real-time monitoring and automatic documentation for construction sites, are hardly in place. Related applications can be found for instance in container handling or mining, where fleets of automated or teleoperated machines are controlled from a central control instance. An on-site wireless connectivity is mandatory for the operation of mobile machines. In case of mixed fleets, an open data and communication standard is crucial to integrate all participants. For the shop-floor communication OPC-UA is a relevant technology to enable interoperability, which can be transferred to other industrial applications such as mining or logistics. Examples for proprietary solutions is the Sandvik AutoMineAPI [5], Kalmar Terminal Logistics System [6] or Cat@ MineStar™ Command [7]. Interestingly, each of these execution systems claims to be open for third-parties and mixed fleets. Hence, interoperability and support for mixed fleets are a concern in these domains, even if there is no uniform standard.

Due to the huge amount of manually controlled construction machines, a comprehensive MES for the construction industry is not mandatory nowadays. An equivalent to an MES for highly automated construction sites is the Site-Execution-System (SES) that was developed in the research project Bauen4.0 and will be further discussed in Sect. 5.

### 3.5 Level 4: Corporate Level

This domain comprises business wide software systems for managing logistics, disposition, procurement, product and document management as well as asset tracking. The business planning and logistics systems are called enterprise-resource-planning (ERP) software and the product related management software is typically known as product-lifecycle-management (PLM). For bigger companies, dedicated software support on this level is crucial. Data sources for construction machine and inventory tracking as well as fleet management are defined by the ISO 15143-3 standard. Thus, telematic data that can be retrieved from the OEMs web server via a REST-API. Other telematic-standards e.g. the FMS-standard for on-road trucks [8] or the VDI 4458 for industrial trucks specify an open, CAN-based interface which enables custom telematics hardware. In the agricultural domain, the *agrirouter* is a common data space approach to link machines and farm-management-systems via a web-API and a standardized, ISOBUS-based telematic unit [9]. A comparison between proprietary and common data spaces as well as the middleware approach is given in [10].

## 4 Using ISOBUS as a Process Control Communication in Construction Machinery

As stated in Sect. 3.3, there are several application specific, open, CAN-based standards that are also implemented in construction machines. Besides diagnostic purposes or machine-implement communication, the use-case of integrating third-party assistance systems is a big requirement for an interoperable data standard. Such assistance systems can be a 3D-machine control systems, tool-management systems, collision warning and avoidance systems (CxS) or weighing systems. Within the research project “Bauen4.0” the integration of an automation system in a crane was taken out by a standardized communication interface based on ISO 11783 (ISOBUS) [11]. This CAN-based standard



has been used for tractor-implement communication for decades and is therefore well developed. This protocol enables a variety of functions, e.g.

- Provision of a structured data model for describing the machine function (device description).
- Connection of any ISOBUS display to the machine and integrating the implements GUI in it (Virtual Terminal)
- Transmission of job data and control commands (Task Controller SC)

This very comprehensive protocol enables the realization of an interoperable solution for the automation of the crane. Via so-called device descriptions, the control unit of the crane can provide a hierarchical data model that is transferred during the start-up routine. An exemplary device description for the crane is shown in Fig. 1.

In addition to the information on the GNSS and the load moment limits, the data model includes the information on the individual joints of the crane. In addition to the driven joint axes such as the slewing gear and telescope, the inclination of the rope is also listed here. Each axis is described as a coordinate system in its position to the previous coordinate system via three Cartesian coordinates (X,Y,Z) and three rotation angles (alpha, beta, gamma). It is also stated, which joint is controllable and within which speed and position limits.

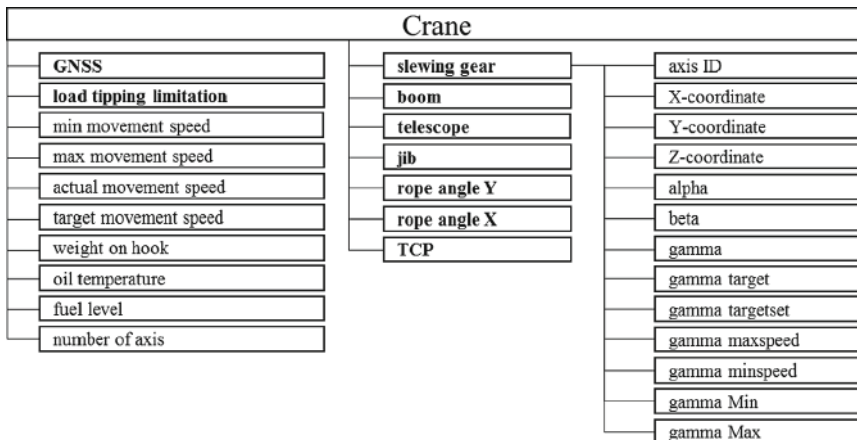
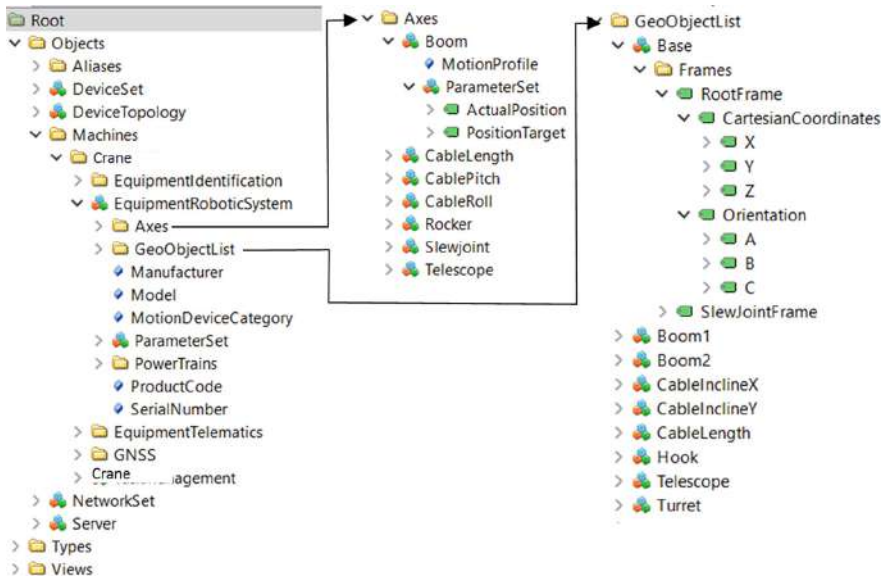

**Fig. 1.** Section of the device description for the crane. Any ISOBUS-specific notation has been omitted. Bold names refer to objects with several sub-variables.

This general representation of the topology of a manipulator is well known in the robotics domain. By using the ISOBUS-protocol, a generic communication approach for interoperable machine control is provided. Automation systems or remote operation devices can make use of this interface in a plug-and-play manner.

## 5 Using OPC-UA for a Site Execution System

The concept of a site execution system (SES) transfers the idea of a MES on the construction site [12]. A mixed-fleet scenario of a highly automated construction site can only succeed, if all machines implement a uniform interface that is powerful enough to meet the requirements for data throughput, latency, security and scalability. OPC-UA (Open Platform Communications Unified Architecture) is an open communication and data modelling standard that fulfils the requirements of Industry 4.0 applications. In industry-specific working groups, uniform data models (Companion Specification) are developed to enable interoperability among participants. For the construction industry, the authors proposed a draft of a Companion Specification [13]. The “Construction Equipment CS” extends the existing CS “Machinery” and “Robotics” [14, 15]. Figure 2 shows the browser view of the OPC-UA data model for the OPC-UA Server of the crane. The data is hierarchically structured and typed. The folder “Root/Machines/Crane” represents the data model for the actual machine. The sub-folder “EquipmentIdentification” holds the information to identify the asset, such as serial number, manufacturer, software version etc. Within the subfolder “EquipmentRoboticSystem” are the folders “Axes” and “GeoObjectList”. The “GeoObjectList” is a folder object that holds all geometric information of the subsystems including coordinate systems of the joints. The “Axes” folder comprises information about joints in the mechanical structure including variables for the actual and target positions of the joint axes. The folder “EquipmentTelematics” gives information about dynamic status variables such as fuel level, operating hours, etc.



**Fig. 2.** Graphical representation of the OPC-UA data model for the crane. Screenshot from “UAExpert” [16].

The geometric information and joint descriptions can be mapped to the ISOBUS device description given in Sect. 5. A data transfer between OPCUA-Server and ISOBUS can be easily automated. In addition to the robotics interface, the “task management” is an important function module in the OPC UA construction equipment model. Via the task management, jobs can be loaded onto the machine and result reports can be downloaded. This file upload option is used for the crane to transmit e.g. path specifications in the LandXML format, that is used as a standard for digital terrain models, as stated in ISO/AWI TS 15143-4.2. The OPC-UA interface is a contemporary approach for an IP-based machine interface with standardized data models and Industry 4.0-ready communication that is accessible via LAN cable, WLAN or mobile network on site. This middleware approach is a major building block for setting up the SES, the central control instance for the connected and automated construction site.

The SES software aggregates all machine and equipment data in real time, maintains the connections to the machines and enables the assignment of formalized work orders to the machines. The user interface is based on a real-time 3D visualization of the construction machines and various 3D terrain and building models, as can be seen in Fig. 3. Work area restrictions can be set and tasks for automated machines can be transmitted in the form of annotated digital terrain models.



**Fig. 3.** User-Interface for the SES with three construction machines, restricted areas (red) and a target trajectory (yellow). (Color figure online)

## 6 Summary

An important development trend for construction machines is automation and autonomy. Numerous individual prototypes have shown that the automated construction machine is technologically possible. Monitoring and control of automated machines is a crucial

building block here. As this has been implemented for individual machines, the big challenge remains how to integrate mixed fleets into a connected and automated construction scenario. In related industries such as industrial automation or mining, several approaches have been made to specify a uniform and open communication protocol for interoperable, plug-and-play connectivity. The authors of this papers briefly presented some standards and provided a proposal for comprehensive data and communication standards specifically adapted for the construction machine industry. It is not predictable which standard will prevail or if there will be only closed, proprietary solutions. As seen in other industries, comprehensive, open standards would contribute to the establishment of smart, connected and automated construction machines with mixed fleets.

**Acknowledgment.** The described project is funded by the Federal Ministry of Education and Research under the grant number 02P17D230. The responsibility for the content of this publication lies with the author.

## References

1. Gartner Inc. (2023). [www.gartner.com, https://www.gartner.com/en/information-technology/glossary/digitalization](https://www.gartner.com/en/information-technology/glossary/digitalization). Accessed 20 Mar 2023
2. Deloitte Touche Tohmatsu Limited, “Engineering and construction industry playbook,” October 2020. <https://www2.deloitte.com/us/en/pages/manufacturing/articles/connected-construction-site-implementation-playbook.html>. Accessed 20 Mar 2023
3. Schober, K.-S., Nölling, K., Hoff, P.: Digitalization in the construction industry - Building Europe’s road to “Construction 4.0”, Roland Berger GmbH (2016)
4. VDMA e.V., “Machines in Construction 4.0,” VDMA, 05 December 2022. <https://www.vdma.org/machines-in-construction-40>
5. Sandvik, A.B.: [www.rocktechnology.sandvik, https://www.rocktechnology.sandvik/de/produkte/automatisierung/automine-maschinenautomatisierung-und-teleoperationssysteme/automine-underground/automine-access-api-f%C3%BCr-lader-und-muldenkipper/](https://www.rocktechnology.sandvik.com/de/produkte/automatisierung/automine-maschinenautomatisierung-und-teleoperationssysteme/automine-underground/automine-access-api-f%C3%BCr-lader-und-muldenkipper/). Accessed 05 Apr 2023
6. Lehto, T., Hämäläinen, J., Poutanen, H.: Open interfaces in a terminal automation platform. Cargotec Finland Oy (2017)
7. Caterpillar, CAT MineStart Command - ARE YOU READY TO START YOUR JOURNEY TO AUTONOMY? (2020)
8. LogiCom GmbH. <http://www.fms-standard.com/>. Accessed 06 Apr 2023
9. DKE-Data GmbH & Co. KG, “Herstellerunabhängiger Datenaustausch ist Realität,” Pressemitteilung SIMA, Paris (2019)
10. Waurich, V., Will, F.: The role of construction machinery on an automated and connected construction site. In: VDI-Smart Construction Equipment - White Paper (2020)
11. Rothmund, M., Wodok, M.: ISOBUS –eine systematische Betrachtung der Norm ISO 11783, Precision Agriculture Reloaded – Informationsgestützte Landwirtschaft, pp. 163–166 (2010)
12. Beck, B., Waurich, V.: Press release - Site Execution System. Technische Universität Dresden, Dresden (2022)
13. Köhler, S., Waurich, V., Itz, D., Beck, B., Weber, J., Will, F.: Netzwerkschnittstellen für mobile Arbeitsmaschinen im Kontext der digitalisierten Baustelle, in 8. Fachtagung Baumaschinentechnik, Dresden (2020)
14. VDMA e.V., “VDMA 40001-1:2022-05 - OPC UA for Machinery – Part1: Basic Building Blocks,” VDMA e.V., Frankfurt am Main, 2022

15. VDMA e.V., “VDMA 40010-1:2019-07 OPC UA Companion Specification for Robotics (OPC Robotics) – Part 1: Vertical Integration,” VDMA e.V., Frankfurt am Main, 2019
16. Unified Automation GmbH. <https://www.unified-automation.com/de/produkte/entwicklerwerkzeuge/uaexpert.html>. Accessed 05 Apr 2023



# Synthetic Data Generation for the Enrichment of Civil Engineering Machine Data

Marius Krüger<sup>1</sup> (✉), Birgit Vogel-Heuser<sup>1</sup>, Dominik Hujo<sup>1</sup>, Johanna Walch<sup>1</sup>,  
Theresa Prinz<sup>2</sup>, Daniel Pohl<sup>3</sup>, Suhyun Cha<sup>4</sup>, and Cornelia Kerausch<sup>5</sup>

<sup>1</sup> Institute of Automation and Information Systems, School of Engineering and Design,  
Technical University of Munich, Munich, Germany

{marius.krueger, vogel-heuser, dominik.hujo, johanna.walch}@tum.de

<sup>2</sup> Chair of Ergonomics, School of Engineering and Design, Technical University of Munich,  
Munich, Germany

theresa.prinz@tum.de

<sup>3</sup> Sensor-Technik Wiedemann GmbH, Am Bärenwald 6, 87600 Kaufbeuren, Germany

daniel.pohl@wiedemann-group.de

<sup>4</sup> HAWE Hydraulik SE, Einsteinring 17, 85609 Aschheim, Munich, Germany

s.cha@hawe.de

<sup>5</sup> BAUER Maschinen GmbH, BAUER-Straße 1, 86529 Schrobenhausen, Germany

cornelia.kerausch@bauer.de

**Abstract.** Artificial Intelligence (AI) is one of the most auspicious technologies in the mobile machine domain. It promises to optimize the machine operation to reduce energy consumption or provide an assistant function to support the operator in challenging machine movements. A large amount of machine data is required to train and build AI models. These data sets are often not available due to missing or faulty sensors in the machine. However, construction machines are partly equipped with temporary sensors for data collection so that small data sets are available. Nevertheless, these data sets are very small and must be extended with more realistic data. Generating synthetic data to enrich real data is a promising approach to overcome the obstacle of small data sets. This paper presents a data generator to produce synthetic, physically-informed data for the pendulum trajectory of a flexible attachment tool on a construction machine. The data generator calculates a reference trajectory based on a physical model of the machine. This reference trajectory is generated by solving an optimization problem to cover the machine movement that an experienced machine operator would drive. Reasonable deviations of these trajectories are generated by varying machine characteristics and adding external forces to the physical model to simulate rough environmental conditions. The data generator is implemented for the grab system movement of a civil engineering machine.

**Keywords:** Civil Engineering Machine · Trajectory Planning · Synthetic Data

## 1 Motivation and Problem Statement

The automation and digitalization level in the construction domain is increasing. Digital infrastructures like the Industrial Internet of Things (IIOT) are integrated into construction sites and the planning and execution of construction processes is accomplished by simulations, Building-Information-Management (BIM) tools and Digital Twins (DT) [1]. Artificial Intelligence (AI) and Machine Learning (ML) technologies promise to extend DT with monitoring, analysis and intelligent decision support features. ML is entirely data-driven and a vast amount of data of suitable quality is crucial to train ML models to a usable level. Data from construction sites and construction machines must be collected, shared over several data stakeholders and processed for ML [2]. However, data collection under rough environments on construction sites requires that sensors are mounted on the construction machines and a suitable data collection architecture for the overall construction site is installed. The challenges in data collection from real construction machines become obvious by considering large-scale machines used for civil engineering. The construction machines are equipped with changeable attachment tools to move large quantities of soil. These construction machines for civil engineering, such as excavators or diaphragm wall grabs (DWG), operate in cycles. Soil is picked up, removed and deposited. These cyclic machine operations can be partially automated or optimized using data. A promising application for data usage and processing can be the design of an ML-based assistance function that plans an optimal trajectory for the mounting tool to speed up the cyclic soil excavation on time. For the data-driven optimization task, sensor data to track the movements at the mounting tool is crucial. For example, the machine tools must be equipped externally with inclination sensors to collect machine movement data. In the state-of-the-technology, these sensors are not typically mounted on the machines because they can be damaged and destroyed during machine operation. Nevertheless, some civil engineering machines are prototypically and temporarily equipped with sensors to track machine movements. A small data set exists but is very limited and often needs to be larger to train an ML model with low bias, low variance and high generalizing behavior for data-driven trajectory optimization. To overcome the challenge of small data sets, real machine data can be enriched with synthetic data that covers the real machine behavior and considers some deviations in the machine tool trajectories. For example, the optimal trajectory of an underactuated excavator boom with limited deflections of the underlying hydraulic cylinders depends on the mass of soil and external disturbances like wind. Changes in influencing variables can be considered during synthetic data generation to provide a dataset of suitable volume and quality for an ML-based, data-driven optimizer. This application example highlights the benefits and promising opportunities of enriching sparse data sets of real construction machines with synthetic, physically-informed data sets that cover the machine behavior. In general, ML enables to supporting the operator of construction machines in the execution of repeating tasks. However, ML-based control methods must be trained sufficiently using a large set of training data. The training data set must cover the full range of relevant machine motion scenarios. These include machine movements that are imposed by the operator's control commands on the one hand and movements that result as a response of the machine to external influences on the other hand. One obstacle is that in practice there is often insufficient data available from real machines for the machine movements.

The enrichment of real machine data with synthetic plausible data promises to close the gap of small data and enables ML-methods.

This paper deals with the challenge of small data sets for civil engineering machines. It contributes a generator for synthetic data that calculates an optimal trajectory of a machine tool under constraints and some physically-informed deviating trajectories. The data generator focuses on calculating plausible deviations of trajectories, which occur due to external influences during real machine operation. The data generator is designed for construction machines with flexibly mounted tools and is prototypically implemented for a simplified trajectory of a grab tool. Only physical models of the underlying machine movement are used to inform and evaluate the plausibility of the trajectories. The paper is structured as follows: Sect. 2 states the related work. The concept of generating synthetic data is shown in Sect. 3, followed by a prototypical realization in Sect. 4. Section 5 summarizes the results.

## 2 Related Work and Contribution to Current Research

The topic of physically-informed generation of synthetic data that covers the motion of construction machines with pendulum tool trajectories can be subdivided into three branches that must be combined. At first, the motion of the machines and the trajectories are limited by technical constraints (Underactuated System). Secondly, the generated data sets must be physically-informed and must represent trajectories that the machine operator would also drive. It is assumed that these machine operator-driven trajectories can be approximated using the optimal trajectories to move a tool under minimizing constraints like time or pendulum amplitude (Trajectory Planning) due to the well-trained and experienced machine handling by the operator. Very experienced machine operators often have years of experience in handling the machine and, therefore, learn over time how to operate the machine in an optimal way. Lastly, methods to generate synthetic data are taken into account (Synthetic Data Generation). The state-of-the-art is consolidated and presented in Fig. 1.

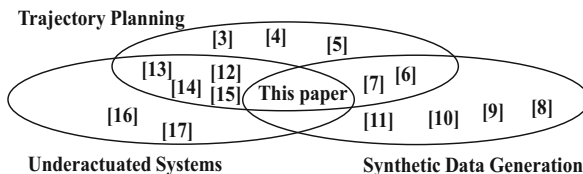

**Fig. 1.** State-of-the-art and classification of this paper into the three branches *Trajectory Planning* [3–7, 12, 15], *Synthetic Data Generation* [6–11] and *Underactuated Systems* [12–17]

Many approaches present methods for trajectory planning for underactuated systems, often in the subject of optimal control methods. It is evident (c.f. Figure 1) that there is related work in the three presented subject areas or combinations of at most two of them. Nevertheless, to the best of the authors' knowledge, there is no approach that deals with all three challenges. In summary, a method to generate physically-informed synthetic



trajectory data for underactuated systems is required to leverage ML to the construction machine domain.

### 3 Concept for Machine Trajectory Data Generation

In the following, the basic concept of generating trajectory data according to the technical design of a construction machine and the underlying physical model is developed. As stated in Sect. 1, the aim is to generate trajectories of a flexibly mounted machine tool for cyclic machine operation under consideration of specific machine geometries. The main idea is to calculate a reference trajectory based on a physical model of the machine. The reference trajectory is the starting point for the modeling of deviation trajectories and can be seen as a type of best trajectory of an underactuated system that an experienced machine operator would drive using the machine controller. Reasonable deviating trajectories are generated by deviating the machine parameters and controller inputs and feeding them into the physical model. For the generation of deviating trajectories, only the parameters of the physical model are varied instead of doing an adjustment of the physical model structure. The authors are aware that an adaption and refinement of the underlying physical model considering the cause of the deviating trajectories would be more realistic for the trajectory calculation. Nevertheless, these adapted, more realistic physical models would be too complex to derive an equation of motion. Therefore, the authors estimate that an adaption of the machine parameters allows a sufficiently accurate generation of deviating trajectories, which can be evaluated by expert knowledge and real observations about the machine movements. In Fig. 2, the concept described above is modeled showing the information flow and several substeps to be performed.

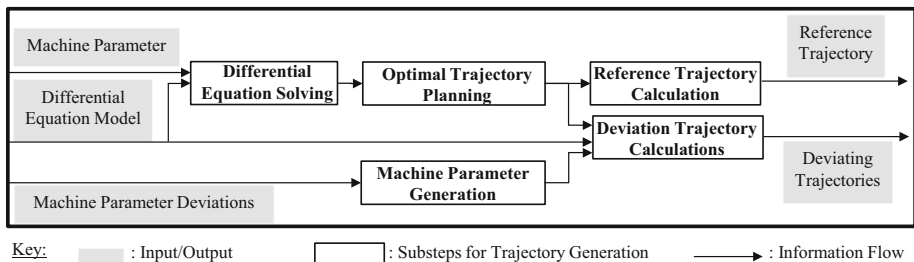

**Fig. 2.** Synthetic data generation. Based on a physical model, a reference trajectory is calculated. Deviating trajectories are generated by varying parameters of the physical model.

The steps in Fig. 2 are explained in the following with references to Fig. 2. The dynamics of the machine and attachment tool are modeled (*Differential Equation Model*) and form the physical basis of the trajectory calculation. The variables (*Machine Parameter*) of the ordinary differential equation system (ODE) are set based on the machine settings. Reasonable deviations of the machine parameters (*Machine Parameter Deviations*) are randomly generated and are in a predefined range. For the calculation of the (*Reference Trajectory*), the ODE system is analytically solved (*Differential Equation Solving*). As far as an analytical solution does not exist, the system must be linearized

and simplified. The resulting system dynamics are represented as state space model. For the trajectory planning (*Optimal Trajectory Planning*), an objective functional is set to evaluate the energy and time consumption as well as state space variables over time. An optimal set of stimulating input variables is calculated to minimize the objective functional. These input parameters are forwarded to the analytical model to generate an optimal trajectory, which can be seen as the best trajectory to move the machine tool under constraints (*Reference Trajectory Calculation*). To calculate trajectory variations in relation to the reference trajectory (*Deviating Trajectories*), the state space model of the system is biased with deviations in the machine parameters and random deviations in the stimulating optimal input parameters. Therefore, the machine parameters, which are represented by the coefficients in the analytical model, are manipulated by adding a deviation that is randomly chosen from a normal distribution with predefined mean and standard deviation (*Machine Parameter Generation*). The manipulated state space model is solved feedforward using the varied optimal input parameter sets (*Deviating Trajectory Calculations*). The resulting reference and deviating trajectories are exported as look-up-tables.

## 4 Evaluation and Discussion

The basic concept for generating synthetic data, presented in Sect. 3, is applied to a use case from civil engineering. The use case is briefly introduced in Sect. 4.1. In Sect. 4.2, the reference trajectory is calculated and discussed (upper part of Fig. 2) followed by a generation of the deviating trajectories (lower part of Fig. 2) in Sect. 4.3. Section 4.4 discusses the results and introduces the procedure to enrich real trajectory data with synthetically generated trajectories. Bold characters state a vector and underlined and overlined symbols mark a variable's left and right bounds. The motion's initial state (end state) is indicated by 0 (end). A subscript d indicates a deviation in the calculation of the deviating trajectories. All results in the figures are given without a unit and can be compared quantitatively.

### 4.1 Use Case: Diaphragm Wall Grab

A diaphragm wall grab (DWG) is considered. DWGs are used in civil engineering to excavate soil from diaphragm walls. These machines consist of a carrier machine, on which a flexibly mounted gripper is attached. In Fig. 3, the DWG and the simplified physical reference model are sketched. The gripper is moved by the machine operator in such a way that it is placed over the wall. The machine operator strives to place the grab in a short time and with a small swing amplitude because the grab is moved down in the wall after placement. The trajectory of the grab that an experienced machine operator would drive can therefore be characterized as an optimal trajectory.

### 4.2 Reference Trajectory

For the physical system in Fig. 3, friction is neglected and the dynamic can be fully described by the generalized coordinates ( $\mathbf{q}$ ), which are the swing angle of the pendulum grab  $\alpha(t)$  and the position  $p(t)$  of the mast in x-direction ( $\mathbf{q} = (\alpha, p)^T$ ).

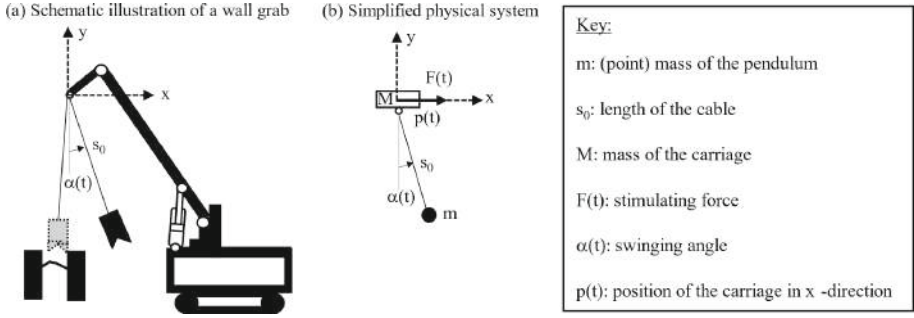

**Fig. 3.** (a) Simplified illustration of a DWG to excavate soil from diaphragm walls. (b) Simplified physical reference system derived from (a).

The non-conservative force  $F(t)$  stimulates the carriage. For the generation of an equation of motion, the system in Fig. 3 is described in the Lagrangian formalism. The equation of motion is easily derived from Lagrange's equation. The motion is described by Eq. 1 with  $\dot{\mathbf{x}}(t) = \mathbf{f}(\mathbf{x}, \mathbf{u}, t)$  and  $z_1 = \alpha$ ,  $z_2 = \dot{z}_1 = \dot{\alpha}$ ,  $z_3 = p$  and  $z_4 = \dot{z}_3 = \dot{p}$ .

$$\dot{\mathbf{x}}(t) = \begin{pmatrix} \dot{z}_1 \\ \dot{z}_2 \\ \dot{z}_3 \\ \dot{z}_4 \end{pmatrix} = \begin{pmatrix} z_2 \\ \frac{s_0 \cdot m \cdot \cos(z_1) \cdot \sin(z_1) \cdot z_2^2 + F \cdot \cos(z_1) + M \cdot g \cdot \sin(z_1) + g \cdot m \cdot \sin(z_1)}{s_0 (-m \cdot \cos(z_1))^2 + M + m} \\ z_4 \\ \frac{s_0 \cdot m \cdot \sin(z_1) \cdot z_2^2 + F + m \cdot g \cdot \cos(z_1) \cdot \sin(z_1)}{-m \cdot \cos(z_1)^2 + M + m} \end{pmatrix} \quad (1)$$

Equation 1 can be analytically solved using small-angle approximation and linearization. The trajectory describes the motion of the grab to move the carriage from position  $\mathbf{x}_0 = (\alpha_0, \dot{\alpha}_0, p_0, \dot{p}_0)^T$  to position  $\mathbf{x}_{end} = (\alpha_{end}, \dot{\alpha}_{end}, p_{end}, \dot{p}_{end})^T$  while a small deviation of the final position in x-direction is allowed. The carriage is moved by the actuating variable  $u = F$ . To cover real machine behavior, the swing angle, as well as the angular velocity, must be relatively small because the alignment of the grab above the wall must be precise so that the grab can be dropped down in freefall. Further, the movement of the upper carriage must be as fast as possible to align the grab in time. This leads to an optimization problem that can be described by the objective functional in Eq. 2. The trajectory (Eq. 2) depends on the relation of the weighting factors  $w_t$ ,  $w_u$ ,  $w_\alpha$ ,  $w_{\dot{\alpha}}$ .

$$J = \int_{t_0}^{t_{end}} w_t + \left( w_\alpha \cdot \alpha(t)^2 + w_{\dot{\alpha}} \cdot \dot{\alpha}(t)^2 \right) + \left( u(t)^T \cdot w_u \cdot u(t) \right) dt \rightarrow \min \quad (2)$$

$$s.t. \quad \dot{\mathbf{x}} = \mathbf{f}(\mathbf{x}, \mathbf{u}, t); \quad x(t_0) = x_0; \quad \underline{x} \leq x(t_{end}) \leq \bar{x}; \quad \underline{u} \leq u(t) \leq \bar{u} \quad \forall t \in [t_0, t_{end}]$$

In Fig. 4, the reference trajectories are generated and evaluated by demonstrating some example initializations for the motion task to drive from  $\mathbf{x}_0 = (\alpha_0 = 0, \dot{\alpha}_0 = 0, p_0 = 0, \dot{p}_0 = 0)^T$  to  $\mathbf{x}_{end} = (\alpha_{end} = 0, \dot{\alpha}_{end} = 0, p_{end} = 10, \dot{p}_{end} = 0)^T$ . The lower and upper bounds of  $u$  are set to  $\pm 2\,000$ . The end state, see Fig. 4 (a), is reached as fast as possible without pendulum oscillations and the presented trajectory leads to the time optimal solution with high actuation in  $u$ . The motion task in Fig. 4 (b) is performed slowly, which fits the expectations due to a high penalty in the actuating variable. The oscillations are very small, which is caused by the small stimulations of the system. In Fig. 4 (c), a trajectory is presented that avoids high oscillations. In summary, all trajectories follow the motion tasks induced by the weighting factors.

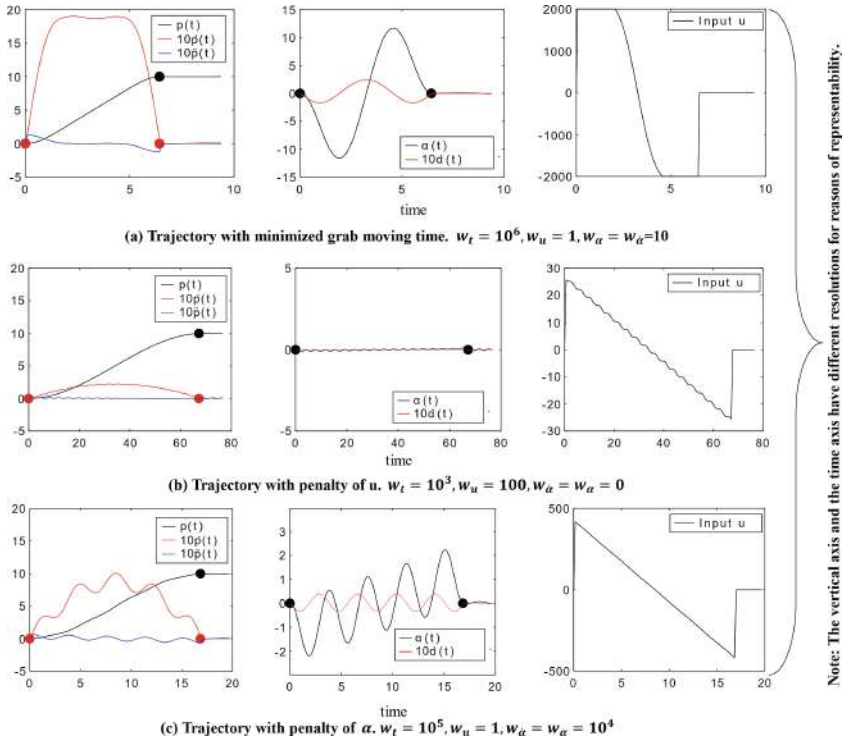

Fig. 4. Optimal trajectory for different configurations of the weighting factors.

### 4.3 Deviating Trajectories

The deviating trajectories, in the following marked by a subscript  $d$ , are generated by considering deviation in the machine parameters, additional external forces, additional machine dynamics resulting by the pendulum behavior and deviations in the actuating control inputs. The mass  $m$  of the pendulum is loaded with an additional mass  $m_{soil}$  to consider the mass changes of the pendulum during excavating ( $m_d = m + m_{soil}$ ). The

pendulum dynamic is also dependent on external stimulation caused by wind. In the real application, the cable is not rigid but elastic and responds to external stimulations with longitudinal oscillations ( $s_d = s_0 \cdot \cos(2 \cdot \pi \cdot s_{freq} \cdot t)$ ) with frequency  $s_{freq}$  and amplitude  $s_0$ . The mounting point of the rope can also move in the y-direction due to the oscillation of the pendulum so that an oscillation is applied to the y-direction of the carriage and  $y_d = y_{ampl} \cdot \cos(2 \cdot \pi \cdot y_{freq} \cdot t)$  with the amplitude  $y_{ampl}$  and the frequency  $y_{freq}$ .

An external force  $F_{wind}$  is applied to the pendulum mass that stimulated the mass  $m$  in the x-y-plane with  $\mathbf{F}_{wind} = F_{wind} \cdot (\cos(\alpha_{wind}), \sin(\alpha_{wind}))^T$  where  $\alpha_{wind}$  describes the wind deviation to the x-axis. The size of the deviating variables is chosen randomly from a normal distribution that a user must initialize with mean and standard deviation. Deviations in the actuating variable  $u$  are generated by adding a general deviation to the calculated optimal control sequence and time-dependent deviations. For the time-dependent deviations, random deviations are added to the control sequence at randomly chosen time steps. In Fig. 5, some deviations are calculated for the motion task described in Sect. 4.2.

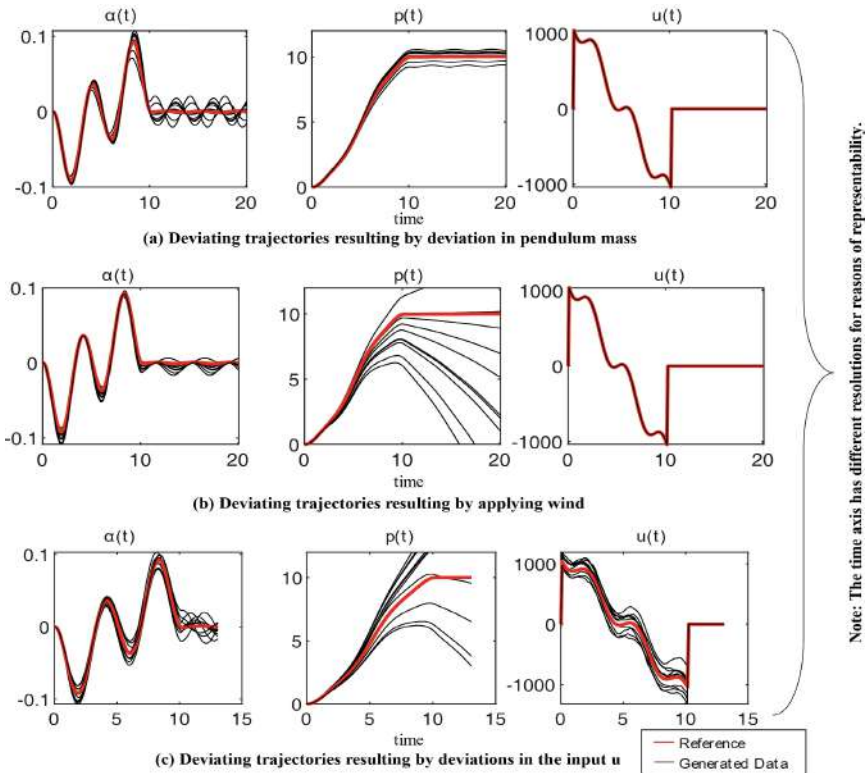

Fig. 5. Deviating trajectories for the same configurations of weighting factors.

In Fig. 5 (a), a mass deviation leads to a change in the frequency of the pendulum, which fits the expectations. The pendulum oscillates further after the end state is reached. This can be explained by a resulting time offset if the mass is to be controlled to the end position by means of the actuating variable. An external force is considered in Fig. 5 (b). The target position is not reached and the pendulum moves further. This is plausible because an additional force acts on the systems and no countermeasures are taken. Figure 5 (c) presents deviating trajectories caused by deviations in the optimal sequence of the deviating variable. The end state can not be reached and additional oscillations occur. Summarizing, deviating trajectories can be generated, which are plausible, validated using expert knowledge.

#### 4.4 Discussion and Enrichment of Real Machine Data

The shape of the reference trajectory depends on the choice of weighting factors. The ratio of the weighting factors to each other determines, which criteria are considered more or less strongly to form the reference trajectories. Weighting factors that best represent the real machine control can be found, for example, by setting up a test matrix and comparing the calculated control variables with the real machine inputs. After experimental determination of the weighting factors, deviating trajectories can be calculated according to the same design of experiment principles and compared with real machine trajectories to determine a reasonable range for the deviations in the machine parameters, external influences and control inputs.

### 5 Conclusion and Further Work

Civil construction machines are challenging to operate, especially for machines with flexibly mounted tools. These machines must be operated so that the attachment tool is driven in a suitable trajectory. AI-based optimizers promise to support the operator in machine control and trajectory movement. However, these data-driven approaches require a large set of training data, often unavailable due to missing sensors. In this paper, a method to generate synthetic data is introduced. The data generation is physically-informed. A DWG is considered and a simplified model for the machine movement is derived. Deviating trajectories are generated by varying machine parameters and considering environmental conditions. The results are evaluated in a first step by construction machine experts and promise that physically-informed synthetic data can cover realistic machine movements. However, the presented method of data generation must be evaluated by comparing synthetic data with the corresponding data of real machines. A small set of real machine data is mandatory. In future work, a DWG will be equipped with sensors to track the machine movements in order to check if the generation of synthetic data using simplified physical models with machine parameter variation can cover real machine behavior. Furthermore, it will be investigated, how the proposed optimization problem and the corresponding weighting factors must be designed and initialized to cover the operator's machine handling. Nevertheless, the presented approach of data generation promises that it can be combined with a test matrix to cover real machine behavior and generate synthetic data.

**Acknowledgement.** This work was supported by the Bayerische Forschungsstiftung (BFS) through the project “Maschinenführer-zentrierte Parametrierung von Artificial Intelligence für eng gekoppelte, verteilte, vernetzte Steuerungssysteme (OpAI4DNCS)”.

## References

1. Günthner, W., Borrmann, A.: Digitale Baustelle- innovativer Planen, effizienter Ausführen. Springer, Berlin, Heidelberg (2011). <https://doi.org/10.1007/978-3-642-16486-6>
2. Nübel, K., Bühler, M.M., Jelinek, T.: Federated digital platforms: value chain integration for sustainable infrastructure planning and delivery. *Sustainability* **13**, 8996 (2021)
3. Latombe, J.-C.: Robot Motion Planning. Springer US, Boston, MA (1991). <https://doi.org/10.1007/978-1-4615-4022-9>
4. Bergman, K.: On Motion Planning Using Numerical Optimal Control. Linköping University Electronic Press, Linköping (2019)
5. Mareczek, J.: Grundlagen der Roboter-Manipulatoren – Band 2: Pfad- und Bahnplanung, Antriebsauslegung, Regelung, 1 edn. Aufl. 2020. Springer, Berlin, Heidelberg (2020). <https://doi.org/10.1007/978-3-662-59561-9>
6. Sarwar, M.U., Sohail, M., Din, M.U., et al.: A dataset generation tool for deep learning-based motion planning in complex environments. In: IEEE ETFA 2021, pp. 1–4 (2021)
7. Zhang, J., Chen, H., Song, S., et al.: Reinforcement learning-based motion planning for automatic parking system. *IEEE Access* **8**, 154485–154501 (2020)
8. Dankar, F.K., Ibrahim, M.: fake it till you make it: guidelines for effective synthetic data generation. *Appl. Sci.* **11**, 2158 (2021)
9. Dankar, F.K., Ibrahim, M.K., Ismail, L.: A multi-dimensional evaluation of synthetic data generators. *IEEE Access* **10**, 11147–11158 (2022)
10. Nikolenko, S.I.: Synthetic Data for Deep Learning, vol. 174. Springer International Publishing, Cham (2021). <https://doi.org/10.1007/978-3-030-75178-4>
11. Emam, K., Mosquera, L., Hoptroff, R.: Practical Synthetic Data Generation: Balancing Privacy and the Broad Availability of Data, First edition. O’Reilly, Beijing, Boston, Farnham, Sebastopol, Tokyo (2020)
12. Jair Martínez López, A., Raúl Pale Suarez, J., Tinoco Varela, D.: Execution and analysis of classic neural network algorithms when they are implemented in embedded systems. In: MATEC Web Conference, vol. 292, pp. 1012 (2019)
13. Shin, J.-H., Lee, J.-J.: Trajectory planning and robust adaptive control for underactuated manipulators. *Electron. Lett.* **34**, 1705 (1998)
14. Wu, Z., Xia, X.: Optimal motion planning for overhead cranes. *IET Control Theory Appl.* **8**, 1833–1842 (2014)
15. Wu, Y., Sun, N., Chen, H. et al.: Nonlinear time-optimal trajectory planning for varying-rope-length overhead cranes. *AA* **38**, 587–594 (2018)
16. Moreno-Valenzuela, J., Aguilar-Avelar, C.: Motion Control of Underactuated Mechanical Systems, vol. 88. Springer International Publishing, Cham (2018). <https://doi.org/10.1007/978-3-319-58319-8>
17. Liu, Y., Yu, H.: A survey of underactuated mechanical systems. *IET Control Theory Appl.* **7**, 921–935 (2013)



# Advancing Construction Efficiency Through Collaborative Robotics: A Scalable Multi-agent-Based Logistics Solution

Dietmar Siegele<sup>1</sup> , Julius Emig<sup>1</sup>, Cinzia Slongo<sup>1</sup>, and Dominik T. Matt<sup>1,2</sup>

<sup>1</sup> Fraunhofer Italia, Via A. Volta 13/A, 39100 Bolzano, Italy  
dietmar.siegele@fraunhofer.it

<sup>2</sup> Free University of Bozen-Bolzano, Piazza Università 1, 39100 Bolzano, Italy

**Abstract.** This research introduces a multi-agent-based logistics system for collaborative construction robotics to address challenges in efficiency, sustainability, and labour shortages. The system consists of and integrates human and robotic agents, creating redundancy and scalability within the construction process. By leveraging digital twin technology and Building Information Modelling (BIM), the system streamlines the entire logistics chain, from material arrival to construction activities. A key innovation is the integration of a modular space concept, in the present case construction container for material preparation and organization. The multi-agent-based approach controls complex logistics, gathering data from BIM and utilizing the data exchange platform Speckle, ensuring seamless collaboration between human and robotic agents. This research has the potential to significantly impact the construction industry by increasing efficiency, reducing waste, and improving project outcomes. The fully integrated workflow enables a high degree of automation in task planning. The proposed method offers a promising outlook for reshaping construction processes and contributing to a more sustainable and resilient built environment.

**Keyword:** Collaborative construction robotics · Multi-agent-based logistics · Construction container

## 1 Introduction

The construction industry is witnessing transformative changes due to robotics and automation, though implementation challenges persist due to the sector's complexity and fragmented logistics. These challenges often lead to delays and cost overruns, attributed to labour-intensive tasks such as material handling, which also pose safety risks. Various issues in site management and logistics complicate the deployment of automated technologies aimed at optimizing time, cost, and safety. Furthermore, the lack of structure in construction sites and the high cost of automation systems necessitate specialized personnel. Despite these hurdles, robotics could address industry issues such as labour shortages, safety concerns, and efficiency. This paper introduces a novel multi-agent-based logistics system that combines human and robotic agents for improved material



and tool management. Our system leverages a digital twin and a modular construction container to enhance site logistics, bringing increased efficiency and resilience. This innovative approach has significant implications for the future of construction robotics and the industry overall.

## 2 Literature

The integration of robotics in construction has gained considerable attention in recent years, with numerous studies investigating various aspects of robotic systems in construction applications. Research has explored the use of multi-agent collaboration for building construction [1], BIM-integrated construction robot task planning and simulation [2], and human-robot collaboration in construction [3]. Further studies have delved into the adoption of automated facility inspection using robotics and BIM [4] and addressed the industry-specific challenges for adopting robotics and automated systems in construction [5]. Moreover the research has covered the current task management process and state of control systems in construction sites, related digital tools and similarities with systems of the autonomous intralogistics sector [6, 7].

The use of multi-agent systems has been explored in various domains, including supply chain risk management [8] and logistics robot scheduling [9]. Learning-based methods of perception and navigation for ground vehicles in unstructured environments have also been reviewed [10]. However, the literature lacks a holistic concept that integrates collaborative robotics in construction logistics, covering the entire process from material transportation to placement and utilization.

While some studies have explored BIM-integrated collaborative robotics for application in building construction and maintenance [11, 12] and BIM-based semantic building world modelling for robot task planning and execution [13], they do not provide a comprehensive approach that includes logistics, since the only creation of three-dimensional site layout plans and 4D coordination of site processes for updating the 4D logistics [14, 15] are not sufficient for an automatic construction logistic management (CLM). Additionally, the concept of digital twins in construction has been investigated [16, 17], but its integration with collaborative robotics for construction logistics remains unexplored. In particular the work preparation is not targeted and limited literature can be found on the topic of on-site fabrication in a modular concept [18, 19]. The on-site production models reviewed, even BIM-based, focus on safety stocks for material and time predictability but are affected by loss of a clear logistic planning where also space is a resource [20].

In summary, the existing literature provides valuable insights into various aspects of robotics in construction and multi-agent systems. However, a holistic approach that combines collaborative robotics and construction logistics, with a focus on both human and robotic agents, is yet to be explored. This paper aims to address this gap in the literature by presenting a comprehensive concept for multi-agent-based logistics for collaborative construction robotics and introducing a modular construction container that is used for work preparation.

### 3 Method

The proposed approach for multi-agent-based logistics for collaborative construction robotics combines a digital twin concept, a modular construction container, a multi-agent control system, and an advanced task planning application. The method leverages the Speckle platform [21] for data exchange, Building Information Modelling (BIM) integration, and the creation of a fully integrated workflow and unique data source for all stakeholders. The following sections provide a detailed overview of each component of the method:

#### Modular Construction Container

The modular construction container serves as a flexible and adaptable system for material preparation, storage, and transportation (see Fig. 1). Modules can be attached or detached depending on the project requirements, enabling material preparation tasks such as cutting bricks or insulation panels. Prepared materials are then packed in the correct order for efficient use on the construction site. Thus, the modular container system enables a streamlined transportation of materials to different levels or areas within the construction site, either by crane or robotic agents, minimizing delays and maximizing productivity.

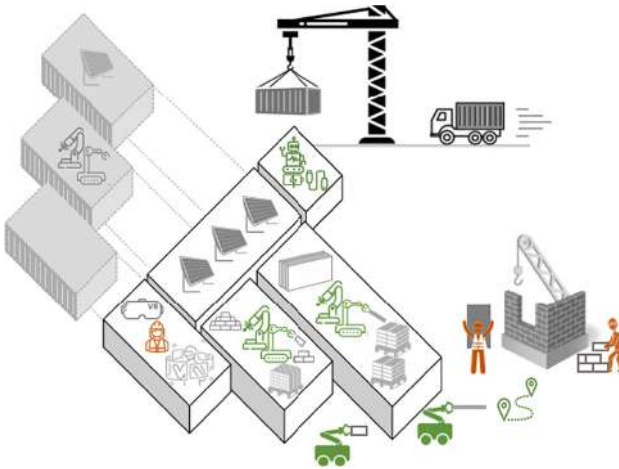
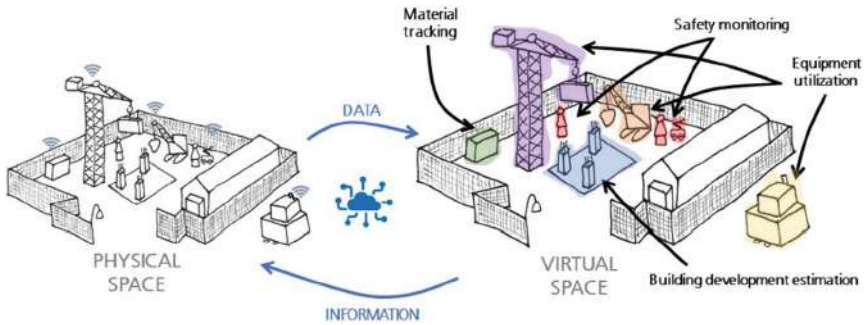

Fig. 1. Modular construction container system.

#### Integration with Speckle Platform Applying the Digital Twin Approach

The digital twin concept enables the creation of a virtual representation of the construction site, including materials, tools, robotic agents, and human personnel. This virtual model is continuously updated based on real-time data collected through sensors and IoT devices, ensuring accurate and up-to-date information for decision-making and task allocation. The digital twin model also allows for better communication, coordination, and visualization among stakeholders, leading to improved overall project management and automated progress monitoring. The establishment of a digital twin framework for

construction site management requires several core components to work together [22]. a physical environment, a digital environment containing the digital model enriched with multi-source data to construct a real-time representation of physical objects, and a communication mechanism used to transfer bi-directional data between the digital and physical twins with real-time data obtained through IoT state synchronisation (see Fig. 2).



**Fig. 2.** Digital Twin concept for construction site

The Speckle platform, an open-source data exchange platform, facilitates seamless communication and data sharing between different software tools and applications used in the AEC (Architecture, Engineering and Construction) industry. By developing the task planning application on the Speckle platform, the proposed method will benefit from seamless integration with existing BIM workflows and software tools, creating a fully integrated workflow and unique data source for all stakeholders involved in the construction logistics chain.

The open-source nature of Speckle allows for easy customization and adaptation to the specific needs of different construction projects. Moreover, the platform's ability to store processes, tasks, and pre-calculated trajectories enables efficient data management and sharing among all stakeholders involved in the logistics chain.

### Task Planning Application

The task planning application, built on the Speckle platform, will be designed to streamline the process of assigning tasks to both human and robotic agents (see Fig. 3). The application leverages the digital twin concept and real-time data from the construction site, intelligently allocating tasks based on factors such as agent availability, skills, and the urgency of tasks. The application will provide a user-friendly interface for monitoring progress, making necessary adjustments to the task schedule, and visualizing the current status of the project. The task planning application will incorporate advanced automation features, reducing the need for manual intervention in various aspects of task planning. For example, the application can automatically generate laying patterns for insulation panels based on the BIM model and construction site data, ensuring that materials are placed in the most efficient and effective manner. Additionally, the application can optimize task sequences and schedules, considering the interdependencies

between tasks and the availability of resources such as tools, equipment, and agents. This level of automation enables seamless coordination between human and robotic agents, ultimately leading to more efficient and productive construction processes.

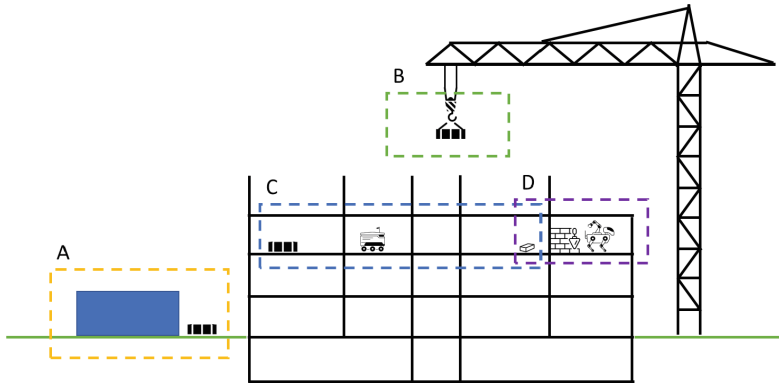

**Fig. 3.** Task Planning Application.

### Multi-agent Control System

The multi-agent control system coordinates the actions of both human and robotic agents involved in the logistics chain. It utilizes a data-driven approach, gathering information from the task planning application and the Speckle platform. Robots receive information about upcoming tasks to their control systems, while humans receive tasks through mobile or smart devices. This coordinated approach ensures that tasks are allocated effectively, taking into account agent skills, workload, and priority, leading to a more efficient construction process. Figure 4 shows potential agents in the presented concept of the modular construction container.

The construction container is a separate agent (here A), the crane (likely to be controlled by a human person is agent B). The tasks of transport (within a storey) and the construction (here of a brick wall) are done by robots (agent C and D). In our concept all agents can be represented either by a human being or a robot. This increases the resilience of the construction process, i.e., to replace a defect robot or to resolve a bottleneck in logistics by adding an additional agent for a limited time. For the multi-agent based control approach we will work with methods and results presented in [23] and [24], based on decentralized systems composed of several modules and cores.



**Fig. 4.** Agents on construction site.

## 4 Expected Results

The proposed method for multi-agent-based logistics for collaborative construction robotics is anticipated to yield several significant results, which are expected to revolutionize the construction industry and contribute to a more efficient, resilient, and sustainable built environment. The presented parts are currently under development and realization. The expected results include:

*Increased Efficiency and Productivity:* The seamless integration of human and robotic agents, automated task planning, and the digital twin concept will streamline construction processes, minimizing delays, and optimizing resource allocation. By automating repetitive labour-intensive and time-consuming tasks, such as material handling, transportation, and placement, the method will allow human workers to focus on more complex and value-added activities, ultimately leading to higher productivity levels, enhanced efficiency and accuracy and reduced construction time.

*Enhanced Resilience and Adaptability:* The multi-agent control system and modular construction container enable the method to adapt to changing project requirements and unforeseen challenges. Since robotic systems can collaborate with human workers, providing complementary skills and capabilities to enhance logistics on construction sites, the system can dynamically allocate tasks to different human or robotic agents based on their availability and skill set, ensuring that the construction process continues even in the face of unexpected disruptions. This adaptability contributes to a more resilient construction process, better equipped to handle uncertainties and fluctuations in the construction environment.

*Improved Communication and Collaboration:* By creating a unique data source and fully integrated workflow through the Speckle platform, the proposed method facilitates better communication and collaboration among all stakeholders involved in the construction logistics chain. This enhanced collaboration will contribute to more effective decision-making and streamlined project management, ultimately leading to a more successful project outcome.

*Cost Savings and Waste Reduction:* The advanced task planning application, automation features, and communication technologies for real-time monitoring, data collection and data analysis can contribute to optimize resource allocation and to more efficient material usage and waste reduction. By optimizing material handling, transportation, and placement, the method will minimize waste generation and help reduce overall construction costs. In addition, the improved efficiency and productivity offered by the method can lead to shorter construction times and cost savings.

*Safer Working Environment:* The integration of robotic agents in the construction process can help reduce the risk of accidents and injuries on the construction site. By automating tasks that involve heavy lifting, working at height, or exposure to hazardous materials, the method will help create a safer working environment for human workers and reduce the potential for workplace accidents.

*Scalability and Futureproofing:* The proposed method, built on the open-source Speckle platform, offers a high degree of scalability and adaptability to meet the evolving needs of the construction industry. The modular construction container concept, the multi-agent control system, and the task planning application can be easily adapted and scaled to accommodate new technologies, tools, and construction methods, ensuring that the method remains relevant and effective in the face of ongoing technological advancements.

## 5 Outlook

The future of collaborative construction robotics through multi-agent-based logistics is promising, with potential to revolutionize the construction industry. Key research areas include technological advancements, interdisciplinary collaboration, standardization, education, and sustainability. Embracing innovative technologies like AI and machine learning will enhance decision-making and efficiency in construction processes. A holistic approach that fosters collaboration between architecture, engineering, and construction management is necessary to effectively integrate human and robotic agents. As construction robotics gain popularity, establishing industry-wide standards for safe and effective implementation is crucial. It's also essential to consider potential sustainability contributions, such as waste reduction and resource optimization, while assessing the social impact on employment and worker safety.

## References

1. Ankit, K., Tony, L., Jana, S., Ghose, D.: Multi-Agent Collaboration for Building Construction (2020)
2. Kim, S., Peavy, M., Huang, P.-C., Kim, K.: Development of BIM-integrated construction robot task planning and simulation system. *Autom. Constr.* **127**, 103720 (2021)
3. Liang, C.-J., Wang, X., Kamat, V.R., Menassa, C.C.: Human-robot collaboration in construction: classification and research trends. *J. Constr. Eng. Manag.* **147**, 03121006 (2021)
4. Chen, J., Lu, W., Fu, Y., Dong, Z.: Automated facility inspection using robotics and BIM: a knowledge-driven approach. *Adv. Eng. Inform.* **55**, 101838 (2023)

5. Davila Delgado, J.M., et al.: Robotics and automated systems in construction: understanding industry-specific challenges for adoption. *J. Build. Eng.* **26**, 100868 (2019)
6. Fottner, J., et al.: *Autonomous Systems in Intralogistics – State of the Art and Future Research Challenges*. Bundesvereinigung Logistik (BVL) e.V., DE (2021)
7. Schöberl, M., Bartmann, D., Kessler, S., Fottner, J.: Towards a construction site control system ? Task management in construction operations and intralogistics. Presented at the 38th International Symposium on Automation and Robotics in Construction, Dubai, UAE, 2 November 2021
8. Giannakis, M., Louis, M.: A multi-agent based framework for supply chain risk management. *J. Purch. Supply Manag.* **17**, 23–31 (2011)
9. Huang, Y., Zhu, J.: Modeling and design of multi - agent logistics robot scheduling simulation platform. Presented at the 2017 5th International Conference on Mechatronics, Materials, Chemistry and Computer Engineering (ICMMCCE 2017), September 2017
10. Guastella, D.C., Muscato, G.: Learning-based methods of perception and navigation for ground vehicles in unstructured environments: a review. *Sensors* **21**, 73 (2020)
11. Follini, C., et al.: BIM-integrated collaborative robotics for application in building construction and maintenance. *Robotics* **10**, 2 (2020)
12. Follini, C., Terzer, M., Marcher, C., Giusti, A., Matt, D.T.: Combining the robot operating system with building information modeling for robotic applications in construction logistics. In: Zeghloul, S., Laribi, M., Sandoval Arevalo, J. (eds.) *Advances in Service and Industrial Robotics*. RAAD 2020. Mechanisms and Machine Science, vol. 84, pp. 245–253. Springer, Cham (2020). [https://doi.org/10.1007/978-3-030-48989-2\\_27](https://doi.org/10.1007/978-3-030-48989-2_27)
13. Kim, K., Peavy, M.: BIM-based semantic building world modeling for robot task planning and execution in built environments. *Autom. Constr.* **138**, 104247 (2022)
14. Whitlock, K., Abanda, F.H., Manjia, M.B., Pettang, C., Nkeng, G.E.: 4D BIM for construction logistics management. *CivilEng.* **2**, 325–348 (2021)
15. Whitlock, K., Abanda, F.H., Manjia, M.B., Pettang, C., Nkeng, G.E.: BIM for construction site logistics management. *J. Eng.* (2018)
16. Sepasgozar, S.M.E., et al.: BIM and digital twin for developing convergence technologies as future of digital construction. *Buildings* **13**, 441 (2023)
17. Nour El-Din, M., Pereira, P.F., Poças Martins, J., Ramos, N.M.M.: Digital twins for construction assets using BIM standard specifications. *Buildings* **12**, 2155 (2022)
18. Gharbia, M., Chang-Richards, A., Lu, Y., Zhong, R.Y., Li, H.: Robotic technologies for on-site building construction: a systematic review. *J. Build. Eng.* **32**, 101584 (2020)
19. Brusselaers, N., Fufa, S.M., Mommens, K.: A sustainability assessment framework for on-site and off-site construction logistics. *Sustainability* **14**, 8573 (2022)
20. Magill, L.J., Jafarifar, N., Watson, A., Omotayo, T.: 4D BIM integrated construction supply chain logistics to optimise on-site production. *Int. J. Constr. Manag.* **22**, 2325–2334 (2022)
21. Aec Systems Ltd.: *Speckle* (2023). <https://speckle.systems/>
22. Zhang, J., Cheng, J.C.P., Chen, W., Chen, K.: Digital twins for construction sites: concepts, LoD definition, and applications. *J. Manag. Eng.* **38**, 04021094 (2022)
23. Davide D’Amico, R., Egger, G., Giusti, A., Rauch, E., Riedl, M., Matt, D.T.: Communication concept of deconsim: a decentralized control simulator for production systems. *Procedia Manuf.* **24**, 100–106 (2018)
24. Egger, G., Chaltsev, D., Giusti, A., Matt, D.T.: A deployment-friendly decentralized scheduling approach for cooperative multi-agent systems in production systems. *Procedia Manuf.* **52**, 127–132 (2020)



# Agent-Based Simulation Model for the Real-Time Evaluation of Tunnel Boring Machines Using Deep Learning

Yara Salloum<sup>(✉)</sup>, Elham Mahmoudi, and Markus König

Ruhr University, Universitätsstraße 150, 44801 Bochum, Germany  
yara.salloum@rub.de, koenig@inf.bi.rub.de

**Abstract.** The tunnelling performance can only be predicted with limited reliability, since many subjective assumptions must be made (e.g., regarding the soil layers). Therefore, the production and logistic processes must be continuously measured, evaluated, and adjusted. These include the advance rate of the tunnel boring machine (TBM) and the duration of the ring construction. During the planning phase, simulation models are used to estimate the tunneling project duration depending on information from previous projects, geotechnical properties of the soil, and assumptions regarding possible delays and downtimes. The next level of deploying simulation models in the decision-making process during construction is to create real-time simulation models, which can adopt real-time data as inputs at different time points of the project to update the prediction of the performance. In this paper, we present an approach combining the benefits of the two fields of artificial intelligence and simulation modeling to create a real-time simulation model and use the real-time recorded data of a TBM to train machine-learning models. These models predict the advancing speed, ring building duration, and feed this prediction continuously to the simulation model to get the best estimation of the TBM performance in the short term and the project performance in general.

**Keywords:** Simulation Modeling · Real Time Update · Deep-Learning

## 1 Introduction

The use of simulation models to estimate the construction progress and the project duration is common in the planning phase of spacious projects. In tunneling constructions, simulation models are used in the planning phase to predict the total duration of the projects and to have an insight into the total downtimes. Hundreds of parameters and inputs must be estimated and provided to set up a detailed simulation model. These parameters are indeterministic, so they are usually evaluated by fitting the initial estimation to probability distribution functions (PDFs). Furthermore, these parameters are exposed to many changes during the construction, which are mostly unexpected, and the real-time performance of the project starts to deviate from the estimated one which can lead to a significant increase in the costs. This deviation raises the necessity to update inputs of simulation models continuously to make an enhanced prediction of the project



duration subsequently, for better planning of the next phase of the project. In a previous study by the authors, a concept was presented to update the simulation model at different phases of the project. To update the non-deterministic inputs, hence the PDFs, a combination of real-time data and planning data were used for the fitting process [1]. The accuracy of the generated values by PDFs, for short-term forecasting, is not high, since they are random, and don't reflect the actual situation of the parameters in the next tunneling cycles (boring + ring building). This paper proposes a novel concept to build a hybrid simulation model for the real-time evaluation of the TBM performance using deep learning. The recorded real-time advancing speed (linear speed) during the first phase of the project (specific number of tunneling cycles) will be used to train a long short-term memory (LSTM) forecasting model to predict the advancing speed of the TBM for the next tunneling cycles. This prediction is fed to the agents of an agent-based simulation model using a special interface to update the inputs continuously and give us a short-term prediction of the overall project performance and particularly the project duration. The paper addresses the challenges of combining deep learning and agent-based simulation models like establishing a proper interface between the two models and providing a ring-based prediction of the advancing speed, which can be implemented as an input for the TBM agent-based simulation (ABS) model to simulate tunneling cycles. A case study is performed using the concept and proposed tools to demonstrate the enhancement in the prediction accuracy for a certain project phase.

## 2 Literature

The TBM's performance, mainly the penetration rate (mm/RPM) and advancing speed (mm/min), can be predicted with the help of neural networks and deep-learning models using the recorded data from the TBM. The machine records hundreds of sensor readings every 10 s during the tunnel construction and saves them in the cloud. Such projects can take years, depending on the tunnel length and the surrounding conditions. This provides a huge database for data analysts to learn more about the tunneling process and discover hidden dependencies. This section demonstrates different studies made to predict the advancement rate of TBM recently. In 2019 Koopialipoor and Tootoonchi proposed a deep-learning algorithm to predict the penetration rate. The results of the paper show better performance of the deep neural networks (DNN) over artificial neural networks (ANN) in predicting the target with less mean absolute error [2]. In 2020, Sheil and Mooney showed that the analysis of collected data by modern TBMs presents a substantial opportunity to support the on-site decision-making process with meaningful information. ML models are developed to predict tunneling-induced soil settlement and directly map TBM parameters and soil conditions [3]. Another paper proposes a (LSTM) model to predict the real-time penetration rate using the geological survey data of machine and rock mass parameters. As a result, the researcher proved that the LSTM model outperforms conventional Autoregressive integrated moving average (ARIMAX) and Recurrent neural networks (RNN) models [4]. In 2021, Li, Li, and Guo made use of the LSTM model to predict the total thrust and cutter head torque using only the TBM's data. The model trained data from 4550 tunneling cycles. Each cycle includes a rising phase and a stable phase. The model uses effective features to predict the target in

the stable phase [5]. Another paper showed deep-learning models (RNN, LSTM, gated recurrent units (GRU)) outperform shallow-learning in predicting TBM load parameters [6]. Another approach proposed using LSTM that optimized by a multi-algorithm to perform real-time prediction of TBM cutter-head torque [7]. Joshi and Mahmoudi proposed in another paper a Comparison of various methodologies to detect anomalies in a time series of data taken from a tunneling project [8]. A new paper in 2023 proposed three machine learning methods to recognize the geological anomalies using inputs comprised of synthetic data combined with Gaussian noise that is added to enhance regularization and model robustness. The result shows that the proposed pattern recognition approach exhibits a powerful capability in classifying the unfavorable geology as early as 4.5-8D (D represents tunnel diameter) ahead of the target anomalies [9]. These previous studies perform data analysis for data correlation after the project execution and propose methods to predict the penetration rate of the TBM using sensor data. In more recent papers, real-time data is used to predict the advancing rate for the next time step (next seconds). In this study, we introduce a Multivariate Multi-step deep-learning (DL) model to predict the advancing speed for the next tunneling cycle to update the TBM simulation model and hence update the prediction of the project duration during the tunnel construction.

### 3 Concept

The proposed concept aims to update the input of an agent-based simulation model of the mechanized tunneling construction with the help of artificial intelligence. We developed a hybrid simulation model that communicates with deep-learning models to retrieve data. The deep learning model continuously imports the TBM's real-time sensor data from the cloud and uses them to train a multistep multi-variate LSTM model. This model predicts the advancing speed for the next tunneling cycles. A specialized interface transfers this prediction to the agent-based simulation model as a deterministic input (Fig. 1).

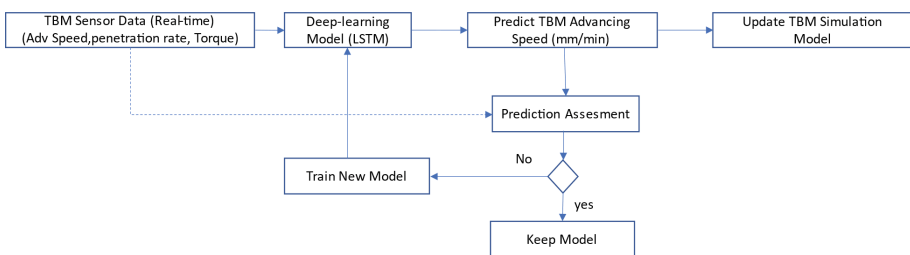

**Fig. 1.** Illustration of a concept to update simulation model with deep learning predictions.

The importance of this concept is the ability to update the simulation model in an early phase of the project. The data from the first several rings will be used to train the deep-learning model. It is necessary to evaluate the prediction accuracy after a few predictions using the error indicators. If the error indication between prediction and real-time data indicates a big deviation, we need to train a new model as our dataset expands. The forecasting problem here is considered a time series problem. The TBM

records hundreds of parameters, signals, and the status of the apparatus every ten seconds. Feature selection methods are applied to choose the sensors of importance to predict the advancing speed, and the time-series forecasting model uses these features to provide predictions. The simulation model continuously calls the predicted advancing speed for the next tunneling cycle from the LSTM model and provide an enhanced prediction of the project's total duration based on real-time data.

### 3.1 Update Inputs of the Simulation Model with the Deep-Learning Prediction

The benefit of using predictions from the LSTM model as input for the TBM simulation model is to avoid non-deterministic input, hence random inputs. This can increase the accuracy of the TBM simulation models in the short-term manners. (Fig. 2). PDF's prediction of a variable at the next time step does not depend on the value at the current time step, the which makes the prediction in the short term less accurate and cannot indicate the current situation of the machine. DL model predicts one value for the next time step  $x + 1$  depending on the value at time  $x$  and the historical data and can indicate the performance of the TBM in the next time step with high accuracy, as we will show in the following study case.

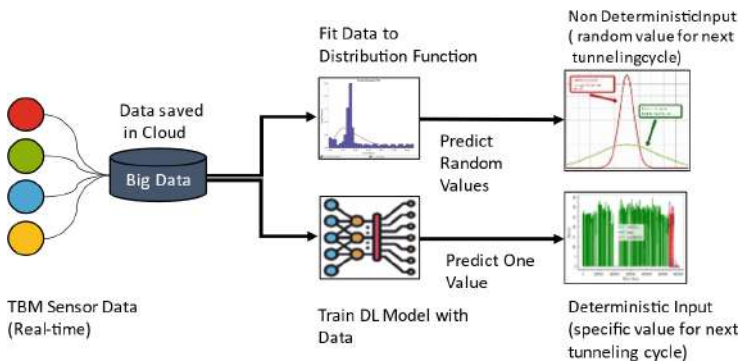

**Fig. 2.** Comparison of distribution functions and deep learning in deterministic input prediction: advantages of deep learning

## 4 Implementation

The implementation of the method can partially depend on the user's software and the model's environment. This paper presents a data pipeline from the cloud to the DL model and to the agent-based simulation model (Fig. 3). The simulation model was implemented using AnyLogic [10]. **AnyLogic** provides special libraries to facilitate connection and data transfer between Python classes and simulation models through the "PyCommunicator" element. In the presented study, we use sensor data provided by the "Maidl Tunnel consultants". Using the provided key, an API (Application Programming Interface) request can call certain parameters from the cloud for a certain time interval and save the data in a JSON or CSV file format [11].

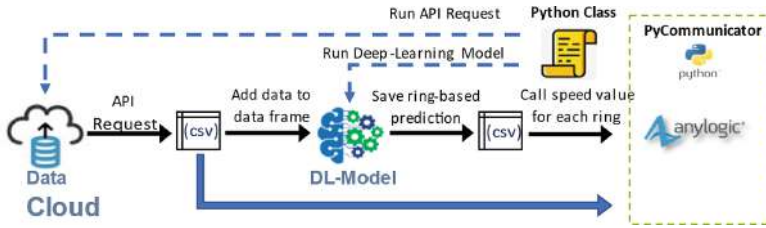
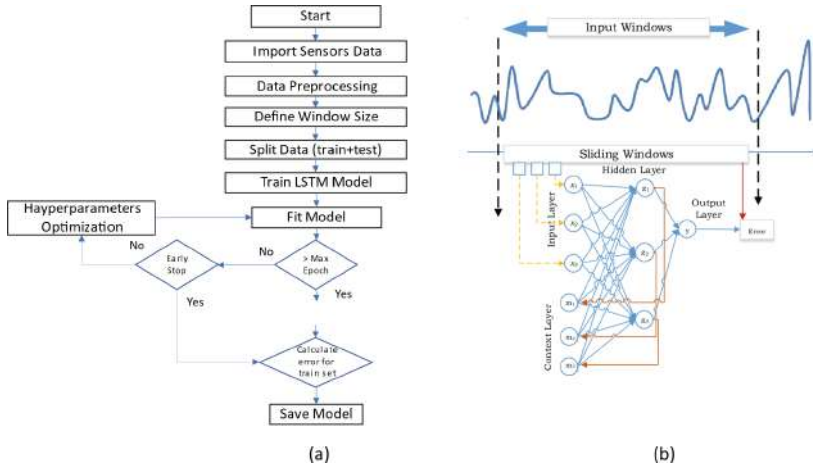

Fig. 3. Data pipeline from data cloud to the agent-based simulation model

#### 4.1 Deep-Learning Model

A Multivariate Multi-step LSTM model with a windowing technique is used to predict the advancing speed [12] (Fig. 4-a). The model consists of two LSTM layers (64 units and 34 units) with an ADAM optimizer and a learning rate of 0.01. The window is moving to put weight on the values from the last three tunneling cycles to predict values for the next one. The loss function is set to mean squared error (MSE). The main goal is to update the simulation model at an early stage of the project with a small size of data at this point. Choosing the right frequency of sensor data can play a role in the prediction process. In our study, the data frame contains sensor data with 1 Min frequency. Data preprocessing includes deleting duplicates, highly correlated features, constants, and low-variate parameters, and removing outliers. Preprocessing will make the data frame more proper for training, especially with the small data size. The model is developed in Python, using various libraries essential to creating deep-learning models and data, and frame preprocessing [13]. We use the windowing technique, where the focus goes to a window of the last set of variables (Fig. 4-b). The essence of this technique is the data update mechanism. This dynamic sample selection mechanism updates the sample for modeling, and the window size determines prediction accuracy. This means adaptively selecting or updating the samples used in the training set as the window slides through the time series data. Instead of using a fixed window of samples for training the model, dynamic sample selection allows for the inclusion of more recent data and the exclusion of outdated data as the forecast horizon advances [14]. This model was able to predict the advancing speed for the next ring with high accuracy using two features of the sensor data, including the penetration rate, and the cutter head torque. The model's forecasting was evaluated with mean absolute error ( $MAE = 0.24$ ) and mean square error ( $MSE = 0.28$ ).



**Fig. 4.** Illustration of the deep learning model and sliding windows technique on RNN

## 4.2 TBM Simulation Model

One simulation method to deal with systems of high complexity is agent-based simulations (ABS). Agent-based simulation models for mechanized tunneling projects are used to create a digital preventative of the processes in the system which are the agents. Each agent has its own behavior and rules to interact with different agents in the same environment. The agent-based model was created using AnyLogic Software [10]. To implement our concept, extra adjustments to the agent-based model are required to connect the advancing speed parameter to the deep learning model [15]. At the end of each tunneling cycle, the `runResults()` function provide new prediction for the next one. The DL model provide predictions for the next ten time-steps. The mean value of these ten values will be the advancing speed for the next tunneling cycle in the simulation model. The PyCommunicator component, which is provided by the Pypline library, connects the DL models with ABS models developed in AnyLogic. The `run()` function is used to call a python file from the simulation model. In our case, we call the API request to post the required sensor data. The `runResults()` function is used to exchange variables between the two models. In our case we use the function to call the prediction model and retrieve the results (speed values) into the simulation model [16].

## 5 Case Study

This case study shows the benefit of using deep-learning algorithm, to update the simulation model of mechanized tunneling construction, to enhance the prediction of the project's total duration. The advancing speed of the TBM is one of the important inputs for the agent-based simulation model to simulate the progress of the process, and the continuous update of it depending on the real-time advancing speed enhances the estimation of the project duration. An experiment of four steps is designed to facilitate the comparison between the model's estimation of the project total duration after updating

the TBM advancing speed in the model in two different methods (see Fig. 5). The first simulation run represents the estimation in the planning phase for the first 39 Rings of the tunnel, and Advancing speed is set to 30 mm/min. This run is made to evaluate the difference between the estimated project duration and the actual one. Another simulation run uses real-time values of the TBM advancing speed to provide a reference value for our proposed comparison. The third run in this case represents a previous concept to implement the advancing speed as a non-deterministic variable that changes during the simulation run [17]. Real-time values from the first 28 tunneling cycles are fitted to a probability distribution function to provide randomly generated values for the advancing speed at each call of the function in the simulation model. The fourth run uses the predicted values from the DL-model. Real-time data from the first 28 tunneling cycles are preprocessed and used to train the deep-learning model. The model provides a prediction of the advancing speed for the next tunneling cycle at each call of the model. A comparison of the resulting project duration is performed to evaluate the concept. This study is based on data and information from the Den Haag tunnel-west in the Netherlands. The tunnel consists of 821 rings and the total duration of the project is about four months and ten days. For the last run, data from the same 28 rings are used to train the LSTM forecasting model. The cutter head torque and the penetration rate are the chosen features to train the model, which are highly correlated to the advancing speed. From this point, the trained model will use data from the last tunneling cycle to predict the advancing speed for the next one until the end of ring 38, and the project duration will be collected at the endpoint for comparison.

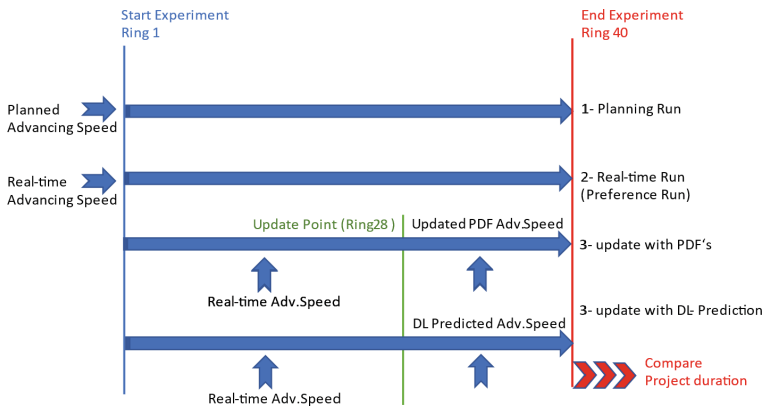
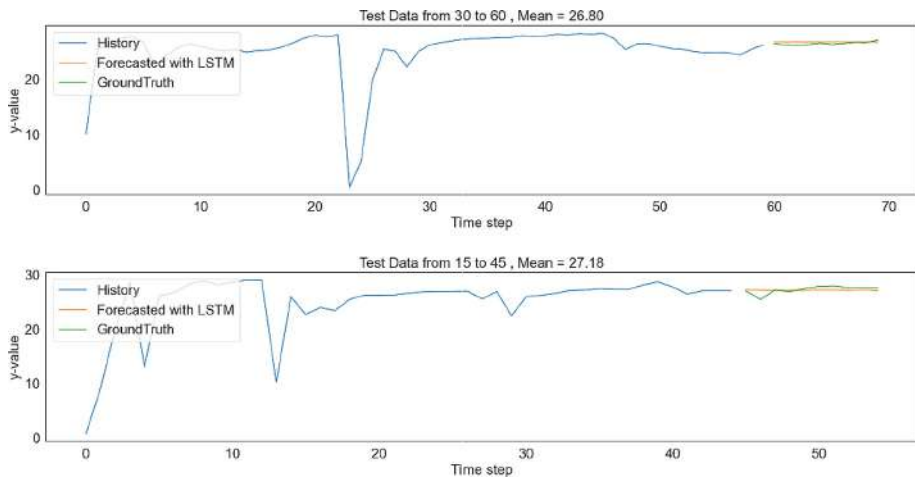

Fig. 5. Illustration of the Study Case Steps to Evaluate the Proposed Concept

## 6 Results

Figure 6 presents the evaluation of the predicted advancing speed using the LSTM model. The mean absolute error and the root mean square error are the indicators to check the accuracy. The first prediction is made after gathering the TBM sensor data of the first 28 tunneling cycles. The DL-model is used to predict the advancing speed for the next

ten tunneling cycles. To illustrate two samples of the prediction, the first chart plots the prediction of the advancing speed for the 29th tunneling cycle, and the second plot displays the prediction of the advancing speed for the 38th tunneling cycle using the same prediction model. Y axis represents the advancing speed values (mm/min). The x axis represents the number of readings in the plot. A window of 30 min is chosen for the windowing technique to predict ten values of the speed for the next ten minutes. The mean value of prediction is used as input for the next tunneling cycle in the simulation model. The results of the four runs are illustrated in the following table (Table 1). The first column represents the tunneling cycle. A first comparison between the first two columns shows the deviation in advancing speed and hence in the project duration between the planning phase and construction phase. The table indicates a delay of one day in the construction of 38 tunneling cycles.



**Fig. 6.** Deep-learning prediction of the advancing speed for two different tunneling cycles

This delay keeps increasing during the progress of the project. The third column contains ten randomly generated values from the beta distribution function, which are called in the simulation model to simulate the progress during the boring phase. A comparison between the second, third, and fourth columns shows the deviation in the speed values in some tunneling cycles more than the others. The fourth column shows high accuracy in predicting the speed values. Accordingly, the estimated duration of the project in the last run shows that using deep-learning model can provide an accurate short-term prediction in general. The real value of the advancing speed shows a slight difference between the tunneling cycles, which indicates a homogeneous soil through these ten rings. The linear prediction is a result of the training with small data set, which doesn't allow the model to detect non-linear behavior at this phase but still gives an accurate prediction of the mean value with  $MAE = 0.3\text{--}0.5$  (mm/min).

**Table 1.** Comparison Between the Advancing Speed Values in Real-Time and Different Prediction Methods

Speed (mm/min)	Planning phase	Real_ time	Random values (PDF's)	DL-model prediction
Ring 29	30	26,89	16,94	26,80
Ring 30	30	28,93	26,31	29,32
Ring 31	30	25,42	27,89	24,56
Ring 32	30	27,86	20,60	27,64
Ring 33	30	25,64	28,94	26,29
Ring 34	30	26,09	18,41	25,09
Ring 35	30	26,98	26,03	27,31
Ring 36	30	27,44	15,75	27,99
Ring 37	30	27,74	29,25	30,86
Ring 38	30	27,073	28,75	27,12
Project time (Days)	8	9	11	9

## 7 Conclusion

The implementation of the method allowed us to compare the quality of predicting the TBM advancing speed using statistical methods and a time-series forecasting model. In the short term, we notice that the predicted speed values are of higher accuracy than the values generated by the fitted distribution function. After several hours, the dataset starts to grow, which allows training a new deep learning model. The DL model can perform the prediction after each ring regardless of the data size of the ring, which is not always possible in the statistical approach, where the small number of data may not be enough to update the distribution function. This concept can lead to a useful simulation model when more variables are predicted with DL models using the available sensor data. One challenge can be the running time of the deep-learning models when one or more models are running simultaneously. Delay in the prediction process can lead to redundancy in the predicted data, and the Simulation model can read the same values cycle after cycle when the prediction values are not updated on time. The robustness of this concept needs to be assessed with different projects to evaluate the ability to predict mechanized tunneling parameters using only sensor data. This prediction is an important decision-making tool and can be more powerful when the forecasting algorithms can predict the ring building duration, and we combine this with early detection of the downtimes using anomaly detection algorithms. Feeding the prediction continuously to the simulation model will enhance the outcome significantly in calculating project duration and downtimes in a short time and investigating ways to optimize the tunneling operation.



## References

1. Salloum, Y., Jodehl, A., Thewes, M., König, M.: From forecasting to real-time process controlling with continuous simulation model updates. In: Proceedings of the 37th CIB W78 Information Technology for Construction Conference (CIB W78), São Paulo, Brazil, pp. 440–452 (2020). <http://dx.doi.org/10.46421/2706-6568.37.2020.paper032>
2. Koopialipour, M., Tootoonchi, H., Armaghani, D.J., Mohamad, E.T., Hedayat, A.: Application of deep neural networks in predicting the penetration rate of tunnel boring machines. *Bull. Eng. Geol. Environ.* **78**, 6347–6360 (2019)
3. Sheil, B.B., Suryasentana, K., Mooney, M.A., Zhu, H.: Machine learning to inform tunnelling operations: recent advances and future trends. In: Proceedings of the Institution of Civil Engineers – Smart Infrastructure and Construction, pp. 74–95 (2020)
4. Gao, B., Wang, R., Lin, C., Guo, X., Liu, B., Zhang, W.: TBM penetration rate prediction based on the long short-term memory neural network. *Underground Space* **6**, 718–731 (2021)
5. Li, J., Li, P., Guo, D., Li, X., Chen, Z.: Advanced prediction of tunnel boring machine performance based on big data. *Geosci. Front.* **2021**, 331–338 (2021)
6. Huang, X., et al.: A real-time prediction method for tunnel boring machine cutter-head torque using bidirectional long short-term memory networks optimized by multi-algorithm. *J. Rock Mech. Geotech. Eng.* **14**(3), 798–812 (2022). <https://doi.org/10.1016/j.jrmge.2021.11.008>
7. Gao, X., Song, X., Shi, M., Zhang, C., Zhang, H.: Real-time forecast models for TBM load parameters based on machine learning methods. [arXiv:2104.06353](https://arxiv.org/abs/2104.06353) (2021)
8. Joshi, K., Mahmoudi, E.: Comparison of various methodologies to detect anomalies in a time series data taken from a tunneling project. In: Proceeding of the 19th International Conference on Computing in Civil and Building Engineering, South Africa (2022)
9. Zhao, C., Mahmoudi, M., Luo, M., Jiang, Lin, P.: Unfavorable geology recognition in front of shallow tunnel face using machine learning. *Comput. Geotech.* **157** (2023)
10. Scheffer, M., Rahm, T., König, M., Thewes M.: Simulation-based analysis of integrated production and jobsite logistics in mechanized tunneling. *J. Comput. Civ. Eng.* **30** (2016)
11. Datacamp. <https://www.datacamp.com/tutorial/making-http-requests-in-python>. Accessed February 2023
12. Machinelearningmastery. <https://machinelearningmastery.com/how-to-develop-lstm-models-for-multi-step-time-series-forecasting-of-household-power-consumption>. Accessed 28 Aug 2020
13. Chollet, F.: Deep Learning mit Python und Kera. In: mitp Verlags GmbH & Co. KG, Frechen (2018). ISBN 9783958458383
14. Sugiartawan, P., Pulungan, R., Sari, A.: Prediction by a hybrid of wavelet transform and long-short-term-memory neural network. *Int. J. Adv. Comput. Sci. Appl. (IJACSA)* **8**(2), 2017 (2017)
15. AnyLogic.com. <https://www.anylogic.com/resources/educational-videos/webinar-pypeline-a-python-connector-library-for-anylogic/>
16. GitHub. <https://github.com/t-wolfeadam/AnyLogic-Pipeline>
17. Medium. <https://medium.com/the-researchers-guide/finding-the-best-distribution-that-fits-your-data-using-pythons-fitter-library-319a5a0972e9>



# A BIM-Integrated Robotics Application for Color Spraying in Construction

Andrea Gagliardo<sup>1</sup>(✉), Simone Garbin<sup>1</sup>, Michael Terzer<sup>1</sup>, Dominik T. Matt<sup>1,2</sup>,  
and Andrea Giusti<sup>1</sup>

<sup>1</sup> Fraunhofer Italia Research Scarl - Innovation Engineering Center, Bolzano, Italy  
[andrea.gagliardo@fraunhofer.it](mailto:andrea.gagliardo@fraunhofer.it)

<sup>2</sup> Faculty of Science, Technology and Engineering, Free University of Bozen-Bolzano,  
Bolzano, Italy

**Abstract.** Construction robotics applications are challenged by the unstructured and dynamic nature of the site environment. The technological challenges to realize automation systems in construction can be alleviated by considering modern approaches that exploit digital representations of physical and functional characteristics of buildings, such as Building Information Modeling (BIM). Our proposed approach allows one to ease the deployment of a construction robotics application through the use of BIM. We exploit BIM-data to enable a user-friendly definition of robot operations on-site through a software library which interfaces BIM with the robot-control software. We demonstrate the application of our approach on a robotic spray-painting case study, exploiting the BIM information to achieve path planning of the cartesian trajectory for spray-painting avoiding areas that must not be colored.

**Keywords:** construction robotics · robot operating system · building information modeling · collaborative robotics · industry 4.0

## 1 Introduction

The building industry is one of the main economies in the world, and its gross domestic product (GDP) in the European Union is grown since 2015 by more than 15% [1]. Problems related to inefficiency, low productivity, a high number of accidents, low attractivity, and a general lack of innovation often arise in construction [2]. Moreover, the construction sector has been considered slow in adopting new technologies and its labor productivity struggles to rise as observed in [3]. For such reasons construction automation concepts are promising for the evolution of the construction sector [4].

Digitalization and automation of processes typically rely on data that can represent the planned or expected state of the real world. Building Information Modeling (BIM) data constitutes a digital representation of physical and functional characteristics of a building. BIM is a shared knowledge resource for

information about a building, forming a reliable basis for decisions during its life-cycle from the earliest conception to the demolition.

The work presented in [5] and [6] shows how BIM can be exploited for mobile robotics using the Robot Operating System (ROS) for navigation. In that work, the geometric and semantic information contained in a BIM-model are used to create a planar floor plan as an occupancy grid map for navigation.

As the majority of construction labor works, painting in construction can be a dangerous activity for the nature of the construction environment; the construction hazard is increased for construction painters that are in contact with chemicals throughout the working-day [7].

Related to robotic painting applications in construction: among recent works, a mobile platform with an actuated 2-joints arm having a roller as end-effector (EE) is presented in [8] to paint autonomously the interior walls of buildings; a scaled down robotic arm with a multi-colour sprayer was developed in [9], and another mobile robot with a spray gun was presented in [10]. All the previous works show how a robotic system can be engaged on such a repetitive and precise task. However, the installation and the setup of such systems can require significant expert user intervention and thus hinders the adoption for non expert users of such applications. To deal with this problem the automation of such activities is a key aspect, and the data stored inside BIM models can be exploited for this goal.

In this work, we combine a software module called ROSBIM [5], that enables the interface between BIM data and a ROS-based robot control architecture with readily available robot motion planning tools, to create a dexterous and autonomous robot, easy to deploy for painting surfaces described in BIM files.

The rest of the paper is structured as follows. In Sect. 2 we detail our proposed approach, in Sect. 3 we describe the application of our approach to a real world scenario and in Sect. 4 we conclude the paper with a mention to related future works.

## 2 Proposed Approach

For this application, we consider a fixed robot arm equipped with a sprayer end-effector that can point towards surfaces of interest to be painted. The basic idea of our proposed approach is described as follows. With reference to Fig. 1, the first step is to extract information of the object to paint. Through ROSBIM we are able to extract geometric and semantic information related to the expected result, e.g. we can extract areas that should not be painted from those to be painted. The area of interest is then passed to a ROS-node which generates the motion plan of the spraying task using ROS<sup>1</sup> and MoveIt<sup>2</sup>. ROSBIM acts as an interface developed to extract geometric and semantic information from a BIM file (Industry Foundation Classes format<sup>3</sup>) and makes these information

<sup>1</sup> <https://www.ros.org/>, last accessed on 14/4/2023.

<sup>2</sup> <https://moveit.ros.org/>, last accessed on 14/4/2023.

<sup>3</sup> <https://www.iso.org/standard/70303.html>, last accessed on 14/4/2023.

available in ROS. It is implemented in such a way that different plugins can be used according to the user's needs, to expose services that allow interaction with the BIM file to extract information for the robot. ROSBIM consists of a Python library that defines a plugin manager, the plugins, and backends. On top of it, a ROS-dependent layer defines ROS messages and services that allow us to control the plugin manager from ROS. The ROSBIM plugin manager handles different plugins: it allows to load, start, stop and unload plugins using a graphic user interface (GUI). Each plugin exposes its services and topics to make relevant information from the BIM model available to the robot. We use IFC-OpenSell<sup>4</sup> as shared backend for all plugins and we use a plugin to extract the geometry and semantic information of specific objects (doors and walls, among others). The semantic information specified in the BIM model are exploited to generate the data to perform the task. For example, the element, its bounding box and the origin of the element with respect to world origin are used to define the painting area.

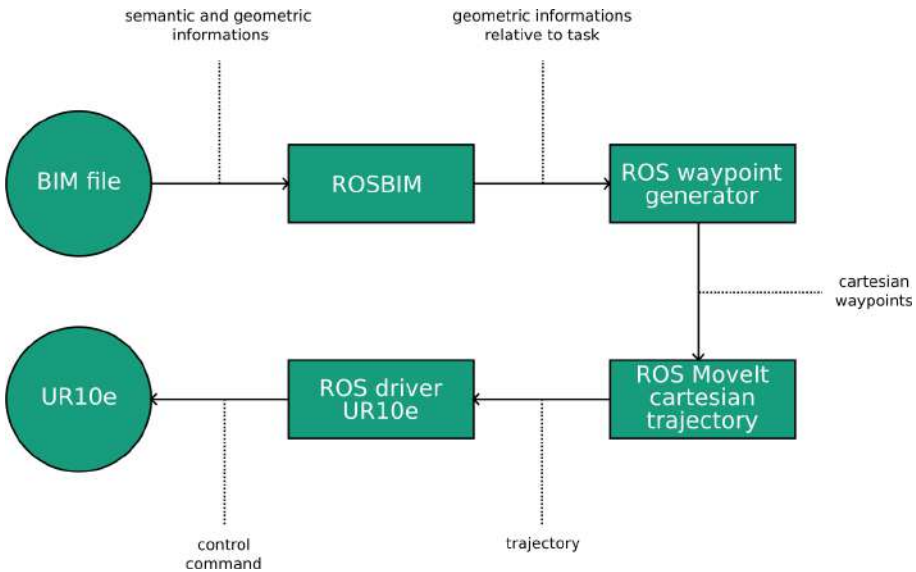
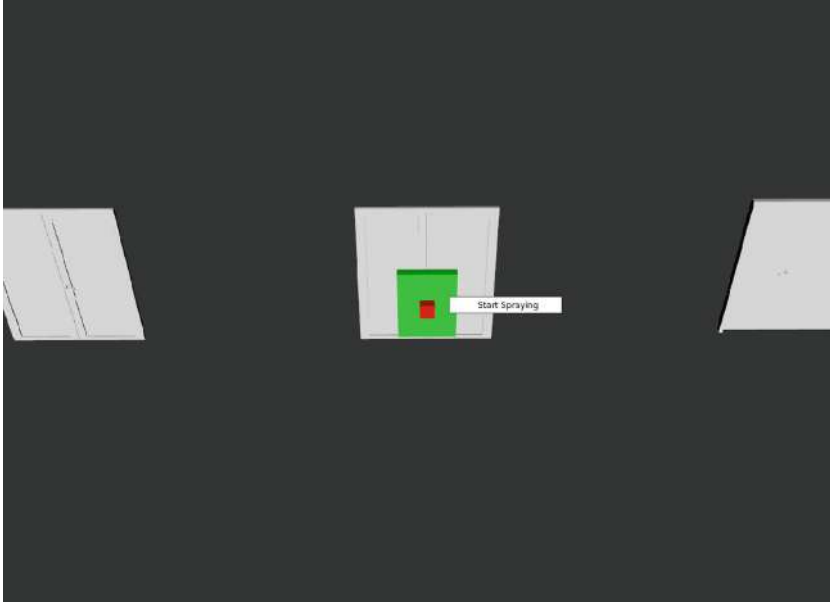

**Fig. 1.** The block diagram of information

The information can be visualized through a graphic user interface that displays extracted geometries and allows the user to interact with them. The user selects the object to be painted and can visualize the presence of sensitive areas (for example switches on wall elements or handles on door elements) where spraying could be avoided thanks to the information extracted from the BIM model.

<sup>4</sup> <https://ifcopenshell.org>, last accessed on 14/4/2023.

These areas are specified directly in the model and a bounding box is automatically created for each area, which corresponds to the no-spraying zone, as shown in Fig. 2. Through the user interface the user can view a green box which shows the area where spraying is possible and a red box showing the area to be avoided during spraying. Subsequently, the user can select to start the spraying for the selected object.



**Fig. 2.** ROSBIM Graphic User Interface

The waypoints to be followed by the robotic arm are calculated in cartesian space with respect to the object frame; considering the green box with width  $w$  and height  $h$ , and giving the spray size  $s$ , starting from the top left corner the points are computed as described in the pseudocode of Listing 1.1; every waypoint ( $waypoint_a$ ,  $waypoint_b$ ) is a vector containing  $x_{wp}$ ,  $y_{wp}$  and  $z_{wp}$  that describe the x, y and z displacements relative to the previous waypoint. The first waypoint is placed on the top left corner of the door, with respect to the door frame. In order to avoid the sensitive area, the Liang-Barsky algorithm [11] is implemented: if the path between two waypoints intersects the sensitive area, new waypoints are recomputed to surround it.

### 3 Application

We verify the applicability of our approach by means of a real world scenario where the method described above is tested. We start from a BIM file that

```

1 h #height of the green box
2 w #width of the green box
3 s #spray size
4 waypoint_list = []
5 waypoint_a = [x_wp, y_wp, z_wp] #initial point top left
6 while( abs(waypoint_a[z_wp]) < h ):
7     if(len(waypoint_list%2==0): #left to right
8         waypoint_b = waypoint_a + [w, 0, 0]
9         Liang_Barsky_check(waypoint_a, waypoint_b)
10        waypoint_list.append(waypoint_a)
11        waypoint_list.append(waypoint_b)
12    else: #right to left
13        waypoint_b = waypoint_a - [w, 0, 0]
14        Liang_Barsky_check(waypoint_a, waypoint_b)
15        waypoint_list.append(waypoint_a)
16        waypoint_list.append(waypoint_b)
17    waypoint_a = waypoint_a - [0, 0, s]

```

**Listing 1.1.** Waypoint generation pseudocode to cover the whole green area

describes the building with a door to be painted. Once the robot base is positioned in range to allow the sprayer to cover the whole door, we launch the ROS MoveIt interface and the system automatically computes the spraying path by exploiting BIM data. The robotic arm used for this experiment is the Universal Robot UR10e, a 6-axis robot manipulator with payload of 12.5 kg and a reach of 1300 mm. To hold the sprayer we developed two custom 3D printed finger caps for the Robotiq 2F-85 adaptive gripper’s fingers. The gripper with our 3D-printed parts can hold and trigger the sprayer, based on the distance between the two fingers. The sprayer utilizes an air jet to nebulize a water-based color solution. Figure 3 shows the digital model with ROSBIM information (a), the real robot in the experiment (b) and the spraying results (c).

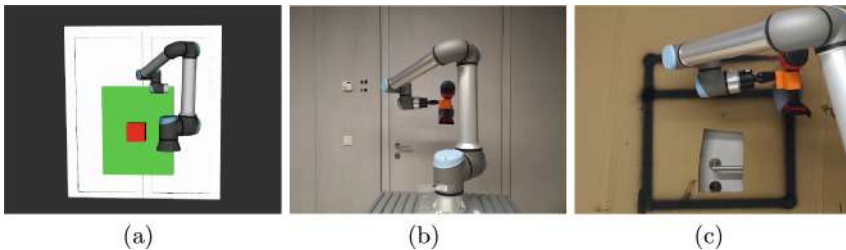

**Fig. 3.** BIM-integrated robotic spray-painting application setup including: (a) a 3D visualization for the user, generated using BIM data, (b) the real robot arm used for the tests, and (c) a result of a spraying test with the proposed approach.

The qualitative results of the experiments show that through a user-friendly deployment we are able to repeatable spray color onto a surface by avoiding no-spray-zones automatically determined from BIM data. As shown in Fig. 3(c), the square defined as no-spray-zone is correctly left unpainted, while the remaining part of the surface defined to be painted is correctly processed. The overall quality is mainly affected by the sprayer accuracy, the velocity of painting and its regulation with respect the solution viscosity, whose optimization was not considered in this work.

## 4 Conclusion

This paper presents a novel application of a robotic system for spray painting that exploits BIM data for easing its deployment. Our approach provides a facilitated way for deploying advanced robotic applications in construction. Therefore, such a solution can contribute to reduce the human presence in hazardous construction environments and to enhance the quality of tasks execution thanks to the high precision and repeatability of robots.

In future work we will explore the application of this approach with a manipulator mounted on a mobile robotic platform to generalise to new use cases. Another promising extension is the optimization of the parameters of the painting task for improving the overall painting quality.

**Acknowledgments.** This work was supported by the European Union's Horizon 2020 Research and Innovation Program under Grant 101016007 (Project CONCERT).

## References







1. Production in construction. Online data code: TEIIS500 last update: 31/03/2023 11:00
2. European Commission. European construction sector observatory - analytical report - improving the human capital basis, March 2020
3. Gharbia, M., Chang-Richards, A., Lu, Y., Zhong, R.Y., Li, H.: Robotic technologies for on-site building construction: a systematic review. *J. Build. Eng.* **32**, 101584 (2020)
4. Saidi, K.S., Bock, T., Georgoulas, C.: Robotics in construction. In: Siciliano, B., Khatib, O. (eds.) *Springer Handbook of Robotics*. Springer Handbooks, pp. 1493–1520. Springer, Cham (2016). [https://doi.org/10.1007/978-3-319-32552-1\\_57](https://doi.org/10.1007/978-3-319-32552-1_57)
5. Follini, C., Terzer, M., Marcher, C., Giusti, A., Matt, D.T.: Combining the robot operating system with building information modeling for robotic applications in construction logistics. In: Zeghloul, S., Laribi, M.A., Sandoval Arevalo, J.S. (eds.) *RAAD 2020. MMS*, vol. 84, pp. 245–253. Springer, Cham (2020). [https://doi.org/10.1007/978-3-030-48989-2\\_27](https://doi.org/10.1007/978-3-030-48989-2_27)
6. Giusti, A., et al.: BALTO: a BIM-integrated mobile robot manipulator for precise and autonomous disinfection in buildings against COVID-19. In: *2021 IEEE 17th International Conference on Automation Science and Engineering (CASE)*, pp. 1730–1737. IEEE (2021)

7. Kaukiainen, A., Riala, R., Martikainen, R., Reijula, K., Riihimäki, H., Tammilehto, L.: Respiratory symptoms and diseases among construction painters. *Int. Arch. Occup. Environ. Health* **78**, 452–458 (2005)
8. Sorour, M.T., Abdellatif, M.A., Ramadan, A.A., Abo-Ismael, A.A.: Development of roller-based interior wall painting robot. *World Acad. Sci. Eng. Technol.* **59**, 1785–1792 (2011)
9. Naticchia, B., Giretti, A., Carbonari, A.: Set up of an automated multi-colour system for interior wall painting. *Int. J. Adv. Rob. Syst.* **4**(4), 50 (2007)
10. Keerthanaa, P., Jeevitha, K., Navina, V., Indira, G., Jayamani, S.: Automatic wall painting robot. *Int. J. Innov. Res. Sci. Eng. Technol.* **2**(7), 3009–3023 (2013)
11. Liang, Y.-D., Barsky, B.A.: A new concept and method for line clipping. *ACM Trans. Graph. (TOG)* **3**(1), 1–22 (1984)





# A Digital Twin Model for Advancing Construction Safety

Jochen Teizer<sup>1</sup>  , Karsten W. Johansen<sup>1</sup> , Carl L. Schultz<sup>2</sup> , Kilian Speiser<sup>1</sup> ,  
Kepeng Hong<sup>1</sup> , and Olga Golovina<sup>1</sup> 

<sup>1</sup> Technical University of Denmark, 2800 Kongens Lyngby, Denmark  
teizerj@dtu.dk

<sup>2</sup> Aarhus University, 8000 Aarhus, Denmark

**Abstract.** Information-driven management and control of physical systems have emerged over the past decade in multiple industrial sectors and more recently also in construction. Such models are called “Digital twins”. However, in the domain of construction, and in particular in its specialty discipline safety, a digital twin (DT) remains rather undefined. Little or no consensus exists among researchers and practitioners of two essential aspects: (a) the connection between the physical reality of a construction site (the “physical” twin) and the corresponding computer model (the “digital” twin) and (b) the most effective selection and exploitation of real-life data for supporting safe design, planning, and execution of construction. This paper outlines the concept for a Digital Twin for Construction Safety (DTCS), defining four essential steps in the DT workflow: (1) safe design and planning for hazard prevention, (2) conformance checking for ensuring compliance, (3) risk monitoring and control for proactive prediction and alerting, and (4) continuous performance improvement for personalized- or project-based learning. DTCS should be viewed as a system-based approach enhancing the overall safety performance rather than exclusively integrating sensing information or safety knowledge in Building Information Modeling (BIM) for safety purposes. The result is an outline of our vision of the DTCS and a description of its modules in essential safety applications. Additionally, we point towards future research and development on this topic.

**Keywords:** Construction Safety · Digital Twin · Building Information Modeling · Site Layout Planning · Monitoring · Education · Training · Equipment · Workforce

## 1 Introduction

Construction is one among the many industries in the world that would greatly benefit from introducing information-driven management of the physical system (e.g., people, processes, technology) to run its operations more efficiently and more safely. Its dynamic workplaces are diverse and rich in sensor data. However, the wide variety of site monitoring and data processing technologies employed, and the subsequent decision making drawn from this data, are yet to be properly integrated within a uniform framework [1].

The problem with this lack of a cohesive, unified framework that integrates the breadth of sensor data, processing technologies and decision-making services, is it results in significant inefficiencies in the operational, physical work environment, as others have documented, for example Sacks et al. [2]. The typical consequences in the case of construction safety are, for example, the cost of poor planning and uninformed decision making is an increased risk of a project being temporarily shut down, a loss in the owner's or contractor's reputation, a worker being forced into absenteeism from work, or of a worker suffering injuries (of which all are preventable) [3].

In the evolution of construction sites becoming data-centric operations, the "Digital Twin" (DT) concept is generally seen as up-to-date digital representations of the physical and functional properties of a system that support decision making, for example, by predicting and analyzing potential future scenarios [4]. For safety in construction:

- the "physical twin" includes construction site events, activities, workers, vehicles and artefacts in the real world (e.g., the placement of a guardrail);
- the "digital twin" is the digital counterpart (e.g., a virtual model of the construction site events, activities etc. that is used to generate simulations for predicting hazardous regions (as detailed by Winter et al. [5]); and
- the "digital twin platform" provides the formal connection between the two twins (e.g., data, information, and knowledge exchange).

Therefore, construction safety digital twins and their accompanying platforms are needed in the value-creating chain of gathering raw data, processing it to derive safety information, and smart decision making at the right-time [6]. Eliminating hazardous pedestrian worker and equipment interactions is one of the applications that would benefit from the emergence of DTs in construction. A need exists to merge the largely independent domains in construction of safety planning, engineering, management, computing, site monitoring, and control methods.

This paper develops the core concepts for developing and implementing an information-driven workflow for safety in the planning and operation of building and civil infrastructure construction. It builds upon existing concepts of Design for Safety (DfS) [7], Job Hazard Analysis (JHA) with Building Information Modeling (BIM) [8], safe and lean project production systems and thinking [9, 10], automated data acquisition, processing, and mitigation frameworks in construction operations [11]. These are integrated through the DT concept, in combination with artificial intelligence methods, to achieve closed-loop control systems for construction safety, which extends the regular BIM-based project design and planning approach that has been utilized until now. The next section provides a state-of-the-art on existing construction safety processes, the importance of data acquisition technologies to monitor physical operations, the emergence of DTs, and the difference to existing information modeling approaches. The further section introduces the digital twin for construction safety which we call DTCS.

## 2 Related Work

### 2.1 Current State of Construction Safety and Level of Information Technology

Thorough Job Hazard Analysis (JHA), careful monitoring, and subsequent control are parts of any successful safety process and management [8]. Combined, these steps fulfill important roles in the hierarchy of controls that make workplaces safer. Over the years, JHA has been established as a well-known practical method for identifying, evaluating, and controlling risk in many industrial sectors. However, the highly dynamic component of construction operations make managing the processes involved in construction site safety more difficult than managing safety elsewhere. For instance, construction operations are typically comprised of unique factors such as: changing site layout conditions; multiple and often temporary work crews; differing in sizes or numbers of machines competing for the same workspace; or rapidly alternating weather conditions. Particularly in construction, a different approach is needed to identify hazards and risks, increase safety, and prevent accidents.

JHA in construction is still a labor-intensive, error-prone, and thus time-consuming process [9]. For determining the priority order of mitigation that needs to be implemented to make workplaces safe, the hazardous component of tasks involved in an activity are analyzed by a safety engineer. Safety engineers are typically trained in workspace planning and health, safety, and environment (HSE), and they evaluate the category of each incident risk by assessing the incident's probability of occurrence and its expected outcome (the level of injury) [8]. Those two measures rank the potential risk in a scale from most negligible to the most severe outcome. According to Chao and Henshaw [12] the process of job site safety analysis is divided into three tasks: (a) loss-of-control identification associated job or activity, (b) assessment of the level of risk for the identified incidents, and (c) action controlling the risk to reduce or eliminate it. However, even with the emergence of BIM methods, the current strategy and investment in construction safety planning, monitoring, and controlling follows manual, time-consuming, and error-prone processes [13].

### 2.2 Digital Twins and Data Acquisition Under Typical Construction Project Constraints

Although construction projects as a whole are highly unique and dynamic, individual construction tasks, methods, and associated risks are fairly well-defined and expected. However, its numerous stakeholders work with, or generate, their own sets of information about products and the process of executing construction works. Under current conditions, few stakeholders are motivated to collaborate intensively with each other which often leads to the use of digital tools with multiple data formats that are not exchangeable. The literature also states that several cases have reported on DTs where there are actually none [14]. As Sacks et al. [14] point out in the effort to establish DT information systems, federated building models that represent as-designed and as-planned states of a project are not DTs. As such, building information models as the digital representation of buildings or infrastructure lack the frequent as-built and as-performed states that are essential to understand construction processes and to continuously improve this

workflow. To make matters worse, construction safety is far behind other disciplines in BIM for which somewhat structured processes and tools exist, for example, estimating construction costs and schedules [6]. Likewise, numerous data acquisition technologies exist that hardly touch the world of construction safety.

There is significant opportunity for DTs that are tailored specifically for construction safety to provide new kinds of decision support to key stakeholders. Primary stakeholders are the HSE coordinators but include all others who have the same responsibility in their job profile (e.g., engineers, planners, construction managers, workers). This potential has greatly stimulated construction safety research and development, although many research efforts often only target the use of a singular technology, without integrating the technology and subsequent analysis into a broader, more comprehensive framework for identifying and preventing hazards, like Teizer et al. have shown for DTCS in [15]. Therefore, this paper extends their work and aims to create a more thorough workflow for planning, controlling, and learning for construction safety using DT information systems. Certain aspects concerning user interfaces are reflected in the research as well. Our method is ‘conceptual analysis’ [16] as a way to establish the foundation of a concept that is based on elementary parts and interdependencies [17].

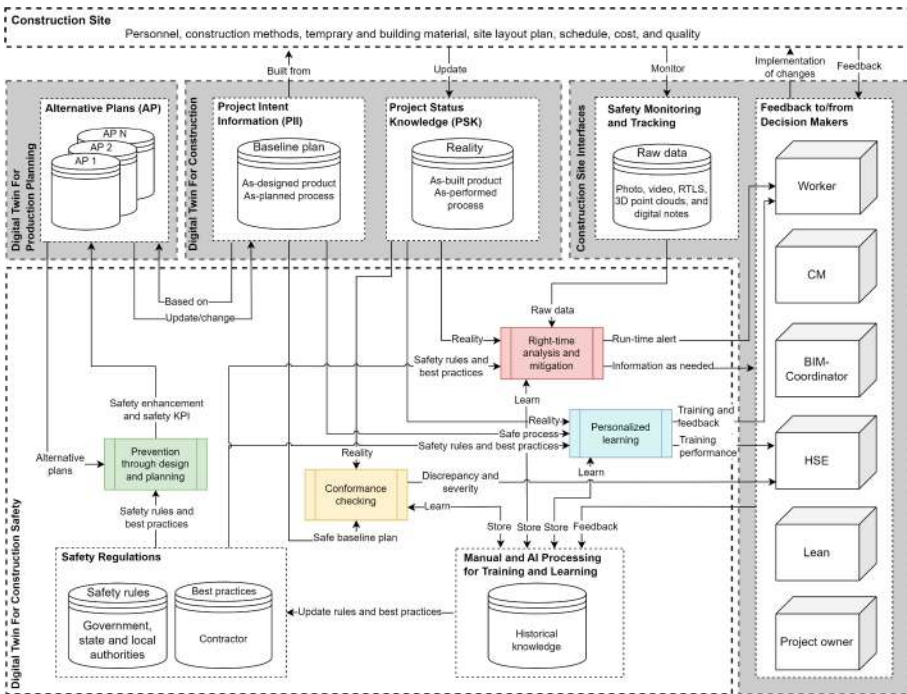

**Fig. 1.** Overview of the Digital Twin for Construction Safety (DTCS) and the relationship and interaction of the physical construction site with the other important Digital Twins (see grey-colored backgrounds, e.g., production planning, construction) and construction site interfaces (e.g., monitoring, tracking, feedback and decision making).

### 3 The Digital Twin for Construction Safety

In this section, we describe how the concept of a DTCS can be created and utilized to actually be a DT. Figure 1 shows the overview of our DTCS (shown in the lower-left corner of the diagram). The DTCS is dependent on other DTs (e.g., lean production, quality), and those should be interconnected in a network that lets them exchange information and knowledge of interest. The DT should also be able to perform tasks for each other. For example, we envision that the Digital Twin for Production Planning (DTPP) requests DTCS to do a safety enhancement and assessment to an alternative production plan or, alternatively, a batch of those. We choose here to concentrate mainly on the DTCS, which means that some details are missing from some of the surrounding modules. This greatly simplified the DTPP, where user interaction, creation, and simulation have been kept outside of the diagram.

In the following, we will elaborate on the inputs, interactions, and outputs of the individual modules of the DTCS. The Prevention through Design and Planning (PtD/P) (denoted in green color) is presented in a more detailed version in Fig. 2a, conformance checking (yellow) in Fig. 2b, the right-time analysis and mitigation (red) in Fig. 2c, and the personalized learning (blue) in Fig. 2d. Thereafter, some brief text and an illustrations (Fig. 3) follow to demonstrate a successful proof-of-concept study of the DTCS.

#### 3.1 Construction Site

The construction site refers to the physical workplace (i.e., the physical twin), which is either being planned, under construction, or constructed. It contains the personnel (e.g., workers, construction management (CM), HSE expert, and lean production/planning experts), construction methods (e.g., consideration of equipment alternatives), temporary resources (e.g., scaffolds, guardrails), building materials (e.g., walls, slabs), and construction plan (e.g., site layout plan, schedule, cost, and quality). The personnel (later referred to as decision-makers) have responsibilities, that need to be considered from a broader perspective to facilitate a productive, safe, and high-quality result.

#### 3.2 Digital Twin for Construction (DTC)

The DTC is a digital representation of the construction site (i.e., the “digital twin” of the physical world, where the physical world itself is referred to as the “physical twin”), which contains both the future potential reality, called Project Intent Information (PII), the past reality, and the present reality, captured in the Project Status Knowledge (PSK) [14]. The construction is built from the PII, namely the Baseline Plan (BP), containing both the as-designed product (how it should be) and the as-planned process (how, and in which sequence, it should be constructed). The PSK is then updated from the physical world (e.g., semi- or fully automated through a combination of raw and processed field data, i.e. real-time location sensing and three-dimensional point cloud data of resources or structures, respectively, of which both are present or appear on the construction site). The PSK also captures the state of the product (as-built product), which is tightly coupled to the design of the product. An example of the state is: the set of walls that have already been placed, and information on whether they have been placed correctly in comparison

to the as-designed product. Furthermore, the PSK captures the performed process of the construction (as-performed process) that can be compared to the as-planned process. The comparison of the two sets of information (i.e., as-designed vs. as-built and as-planned vs. as-performed) generates knowledge about the discrepancy that may be avoided through different planning strategies in future projects.

Through information gathering of historical decision-maker feedback and preferences, and the information from the comparison of planned activity vs. reality, the DT gives knowledge that can be applied to future planned construction activities and projects. For example, this knowledge can facilitate optimized construction safety in terms of task-specific coordination in schedules, budget associated cost in more detail than available before, and ensure higher quality.

### **3.3 Digital Twin for Production Planning (DTPP)**

As mentioned, the DTC contains a BP used to build the physical construction. The DTPP also generates APs with the BP as a starting point, along with the decision-makers' preferences (i.e., based on experiences or internal guidelines). It creates a number of APs that slightly differ in the process, cost, quality, etc. The measures, aka. Key Performance Indicators (KPIs), of the individual plans, are gathered through simulation affected by the historical knowledge that is a part of the DT. Each of the APs is given to the DTCS for enhance- and assessment of safety equipment along with the creation of Safety Key Performance Indicators (SKPI). The KPI and SKPI facilitates the selection of the AP, thus the APs become Safe Alternative Plans (SAPs). The decision makers should be presented with the SAPs (including the related KPIs and SKPIs), from which the decision-makers select an SAP, on an as-needed basis, that aligns with their overall goal and vision. This may happen daily (i.e., for preparing toolbox meetings), weekly, or as otherwise defined in look-ahead schedules. Through this process, the BP is updated/changed continuously with newly collected knowledge. This may well be integrated with ongoing look-ahead scheduling used in construction production planning.

### **3.4 Construction Site Interface (CSI)**

The CSI serves to provide, get feedback from, and give feedback to, the different decision-makers present on the construction site, and thus includes different interfaces. The interfaces are illustrated as different boxes for the individual decision-makers, although some may overlap or extend. The safety monitoring module provides the DTCS with raw data that first must be interpreted into information that can then generate knowledge. It is envisioned that the raw data can contain different sensor data, which once merged create information that is not visible in one sensor output exclusively (aka. Data fusion). Here, digital interfaces (i.e., wearables) that are simple to use for site personnel may provide an additional means to record data or receive communication.

An example is an interface for a construction worker which would be different from the one for construction management. The worker should be alarmed if being in danger and it would not be sufficient if the worker needs to interpret a comprehensive accident investigation report first before being hit by a nearby piece of equipment or a load, but rather is given the (run-time) alert through sound and/or light emitters [11]. To understand

how to act correctly to prevent the accident, the alert type can be accompanied by a push notification on an easy to carry device (e.g., smartphone) stating (in short) to leave the area as crane activity is being carried out. The notification can also inform the worker how to leave the area safely. The crane operator should also be notified. The DT for the crane stops the activity automatically, or the operator does this and waits until the worker has left the operations space. The HSE should be informed about a potential close call and provide feedback to the system, informing about potential strategies to avoid it in the future. The solution can be the use of signs, the addition of virtual spaces (temporal restricted areas), training, or most likely, a combination of these.

### 3.5 Digital Twin for Construction Safety (DTCS)

With the modules mentioned above, we are now ready to describe what happened in the DTCS in greater detail (as shown in Fig. 2). The DTCS consists of four main modules, i.e., PtD/P, Conformance Checking (CC), Right-time Analysis and Mitigation (RAM), and personalized learning (PL). First, we introduce the overall interaction of these modules with their surroundings, and subsequently, we describe their contents. The APs are received from the DTPP for safety enhancement and assessment, which means that the protective safety equipment is added to the model. There may exist more than one way to make a safe plan, which will result in an answer set of different solutions. The solutions are created based on the safety regulation, which holds the information about the applicable safety rules provided by the government, state, and/or local authorities (i.e., [18, 19]). Another component of the safety regulation instance are best practices, which should hold the decision-makers' preferences (e.g., guardrails over safety net). Each SAP is given a collection of SKPIs informing the HSE about the cumbersomeness of, among others, safety equipment installation, protection capabilities, risk analysis. The safety regulation data storage should be updated based on the actual performance of the chosen SAP and the decision-makers' feedback stored in the historical knowledge database.

Based on a CC (green color in Fig. 1) of the SAP and the reality representing the actual construction site, it should be possible to locate discrepancies. These are classified into three levels of severity (i.e., high, medium, and low), provided to the HSE, and stored in the historical knowledge database. The HSE should then act appropriately to the severity, solve the flagged accident, and implement changes to the physical construction site. When an accident has been solved, the HSE should provide feedback to the system (comparable to labeling of data) for future improvement, i.e. learning from output (both information & classification) and recommendations.

RMA provide two kinds of output, i.e., the run-time alerts for the worker, and information as needed for the remaining decision-makers. It is envisioned that a worker in danger should be alerted as soon as possible through an appropriate interface. The information as needed is more elaborated information and includes appropriate mitigation strategies, where further analysis has been performed. This is envisioned as there may not necessarily be time, or necessity, for elaborate mitigation actions in a close call situation, for example, a worker being located in the blind spot of construction machinery. Hence the machinery operator and walking worker should both be aware of the hazardous situation and solve the issue collaboratively. Information and mitigation proposals can be



compiled and handed to the HSE and BIM coordinators for future avoidance of similar occasions. For example, avoidance measures may consist of better signage, a cleaner separation of walk paths and machinery roads, or construction site cleaning, as walk paths may be obscured with construction materials or waste. Once again, it is envisioned that the output is stored along with the decision-maker feedback, from which the module can learn to provide better information and mitigation actions.

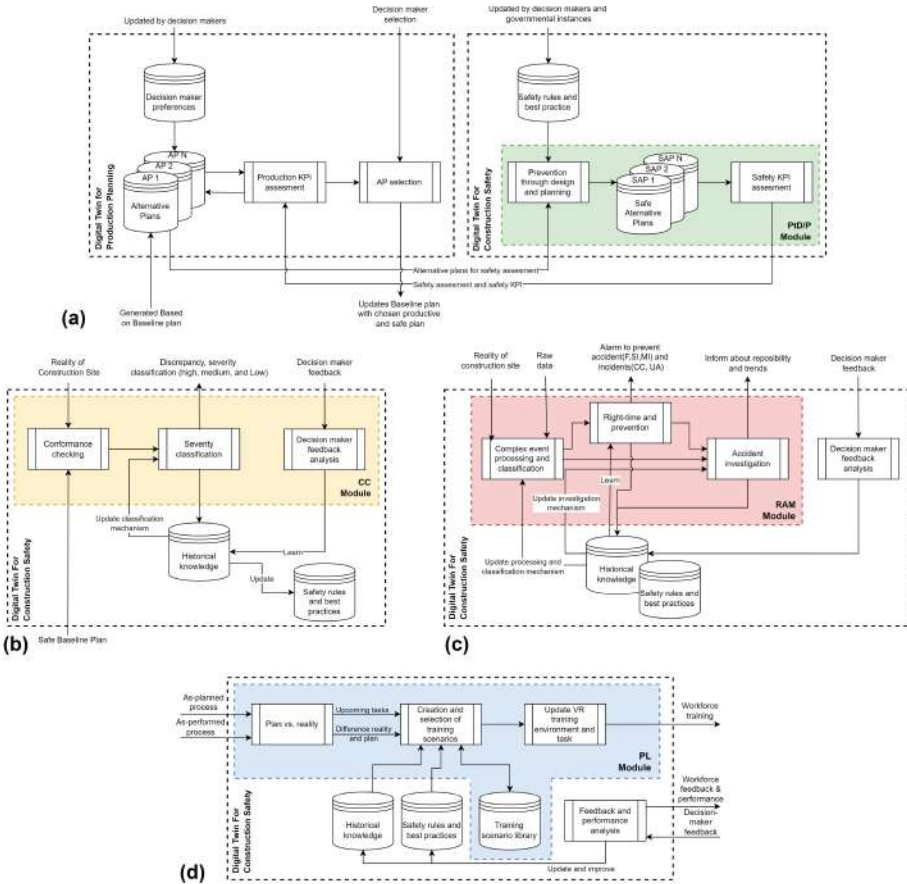

**Fig. 2.** The four DTCS modules: Internal operation of the (a) Prevention through Design and Planning (PtD/P) module. As the in- and output is highly connected to the Digital Twin for Production Planning (DTPP), it is chosen to include it in the diagram, (b) Compliance Checking (CC) module, (c) Right-time Alert and Mitigation (RAM) module, and (d) Personalized Learning (PL) module.

**Prevention through Design and Planning (PtD/P).** The left side of Fig. 2a illustrates how the APs are generated based on the decision-makers’ preferences and the current baseline model. The APs are handed to the PtD/P module of the DTCS (right side of



Fig. 2a, in green color) and enhanced with safety measures (e.g., guardrails to separate pedestrian workers' pathways from heavy construction equipment traffic, schedule changes) based on the safety regulations that apply to the specific construction site (note: this may vary locally). This can, as mentioned, result in more than one SAP for each AP. The system analyses the hazard spaces identified in the design, and hazard spaces identified in the process (e.g., work crews working simultaneously on different stories, creating hazard zones in terms of being struck by an object from above). The SAPs are returned to the DTPP for decision-maker selection, consequently updating the baseline plan from which the construction site is built.

**Conformance Checking (CC).** The conformance checking should find and classify discrepancies between the plan (created in PtD/P-module) and reality (captured by sensors) (Fig. 2b). For example, an incorrectly installed or removed guardrail would result in a relatively high severity. This information is stored, and when the HSE expert has visited the problem, they can provide new information on the correctness of the output (in terms of both incident classification and its severity). This information provided by the HSE expert should be used to improve the classification of future occurrences and to update the best practice. An example of an updated best practice could be to use a safety net in some situations to avoid the repeated removal of, e.g., a guardrail.

**Right-Time Analysis and Mitigation (RAM).** Based on the reality of the construction site, the raw safety monitoring data, historical knowledge, and safety regulation module performs complex event processing and classification, from which the workers are alerted to prevent both accidents (i.e., fatalities, serious injury, and minor injury) and incidents (i.e., close calls and unsafe acts) (Fig. 2c). The module subsequently performs an accident investigation, where the root cause of the incident or accident can be determined and prevented in the future. Also, in this module the feedback to, and from, the decision-makers are stored and used in processing/classification- and investigation mechanisms. The safety rules are also included in this diagram. These are updated and used in the prevention through design and planning module (i.e., the first module of the DTCS), conceptually closing one of the loops of the DTCS.

**Personalized Learning (PL).** The personalized learning module provides a realistic virtual training environment (VTE) for construction personnel for the purposes of hazard recognition and safety awareness training (Fig. 2d). VTEs allow to experience dangers without risking real-life consequences. This module generates a VTE automatically using the available as-planned and as-built information (e.g., SAP and IoT, respectively) which are core elements to build the training scenario. This way, it can reflect the progress and hazards of the project in or near real-time. HSE trainers have the flexibility to embed this module into existing safety orientations and educational courses. They can still implement additional geometric objects to modify the training scenario according to their training needs; for example, elements that may relate to unforeseen products or hazard zones that neither are part of any of the digital input information nor come from the processes happening in reality. This module, as a part of the DTP, eventually performs an objective and yet computational behavioral analysis of the data that is collected from the participants following a selection of known safety rules, and best practices. Overall, the module allows to safely practice the actual upcoming work tasks before they appear

in reality. The framework also emphasizes creating and selecting new training scenarios based on worker feedback and performance.

## 4 Implementation Example

All four modules of the DTCS have been validated. While the scope of this work does not allow to go into depth of the technical DTCS solution, some encouraging results have been reported by the authors of this paper [11, 20–22]. A very brief example is presented (Fig. 3a–c): A known safety rule is to keep pedestrian worker at a safe distance to mobile machinery. As explained earlier, APs in construction projects eventually lead to one SAP, like shown in [4, 20]. Then, state-of-the-art IoT devices can provide with little effort realistic data sets from live construction site operations. Such data, as a central part of DTs, is analyzed for safety purposes, as shown by [11, 20]. While predicting and avoiding accidents is yet an unresolved issue that must be addressed in future research [21], mitigating close calls by issuing right-time alerts has been shown by [11]. All processed data turns into valuable input information for building a highly realistic VTE [22]. Yet, personalizing feedback as part of a VTE leads to new safety knowledge while the participant’s task performance assessment may also focus on other key performance indicators (KPIs), such as quality and time of task execution and completion. This allows project decision-makers and instructors providing active personalized feedback and improving overall performance.

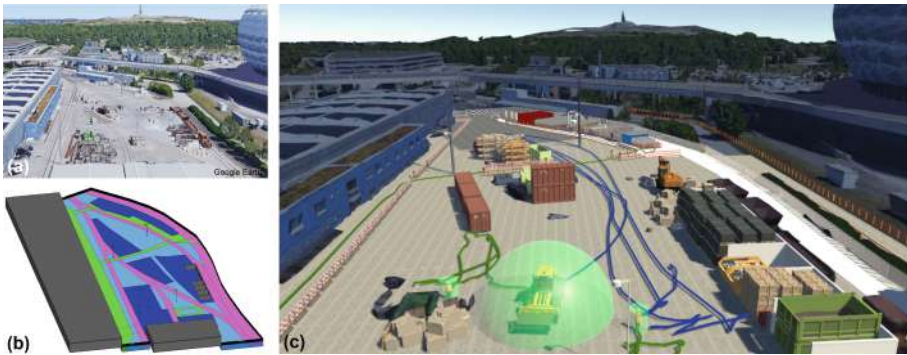

**Fig. 3.** Preliminary implementation: (a) Field trial site in Munich, Germany, (b) Safe Alternative Plan (SAP) as PL input, and (c) DTCS, seen as part of the personalized learning module that integrates the modules PtD/P (safe construction site layout plan based on conformance checking of a building information model, RAM (right-time monitoring, analysis, and mitigation: gathering and analysis of IoT-based real-time construction resource trajectory data; dark green and blue lines), and PL (active learning environment for personalized safety training and feedback).

## 5 Conclusion

This paper presented the new concept of Digital Twins for Construction Safety (DTCS). Like other DTs that represent models for information-driven management and control of physical systems (e.g., people, processes, technology), four essential modules in the process of construction safety were defined: (1) safe design and planning for hazard prevention, (2) conformance checking for ensuring compliance, (3) risk monitoring and control for proactive prediction and alerting, and (4) continuous performance improvement for personalized- or project-based learning. Working from these four core modules, we advocated for a DTCS information system workflow, including information models and rule sets, monitoring technologies, and performance feedback. One successful example of a preliminary implementation of a DTCS was shown. Additionally, we emphasized that the DTCS concept deserves future work, for example, measuring its impact on advancing the current best practices.

**Acknowledgment.** The presented DTCS is part of European Union funded research projects that focus on the overall holistic approach of transforming BIM into DT in the construction phase, including the safe planning and operation of work environments. The research presented in this paper has received funding from the European Union's Horizon 2020 research and innovation program under grant agreements no. 958398 and no. 958310.

## References

1. Teizer, J., et al.: Construction resource efficiency improvement by long range wide area network tracking and monitoring. *Autom. Constr.* **116**, 103245 (2020). <https://doi.org/10.1016/j.autcon.2020.103245>
2. Sacks, R., Koskela, L., Dave, B., Owen, R.L.: The interaction of lean and building information modeling in construction. *J. Constr. Eng. Manage.* **136**, 968–980 (2010). [https://doi.org/10.1061/\(ASCE\)CO.1943-7862.0000203](https://doi.org/10.1061/(ASCE)CO.1943-7862.0000203)
3. Garrett, J.W., Teizer, J.: Human factors analysis classification system relating to human error awareness taxonomy in construction safety. *Constr. Eng. Manage.* **135**(8), 754–763 (2009). [https://doi.org/10.1061/\(ASCE\)CO.1943-7862.0000034](https://doi.org/10.1061/(ASCE)CO.1943-7862.0000034)
4. Tao, F., Zhang, M., Nee, A.Y.C.: *Digital Twin Driven Smart Manufacturing*. Academic Press, Cambridge (2019)
5. Johansen, K.W., Schultz, C., Teizer, J.: Automated spatiotemporal identification and dissemination of work crews' exposure to struck-by hazards. In: CIBW099W123, Porto, Portugal, pp. 1–10 (2023). <https://doi.org/10.24840/978-972-752-309-2>. ISBN 978-972-752-309-2
6. Teizer, J.: Right-time vs. real-time pro-active construction safety and health system architecture. *Constr. Innov.: Inf. Process Manage. Emerald* **16**(3), 253–280 (2016). <http://dx.doi.org/10.1108/CI-10-2015-0049>
7. Toole, T.M., Gambatese, J.: The trajectories of prevention through design in construction. *Saf. Res.* **39**(2), 225–230 (2008). <https://doi.org/10.1016/j.jsr.2008.02.026>
8. Zhang, S., Boukamp, F., Teizer, J.: Ontology-based semantic modeling of construction safety knowledge: towards automated safety planning for job hazard analysis (JHA). *Autom. Constr.* **52**, 29–41 (2015). <https://doi.org/10.1016/j.autcon.2015.02.005>
9. Teizer, J., Melzner, J.: BIM for construction safety and health. In: Borrmann, A., König, M., Koch, C., Beetz, J. (eds.) *Building Information Modeling*, pp. 349–365. Springer, Cham (2018). [https://doi.org/10.1007/978-3-319-92862-3\\_21](https://doi.org/10.1007/978-3-319-92862-3_21). ISBN 978-3-319-92861-6

10. Teizer, J., Melzner, J.: Neue Wege zur Integration von BIM, IoT und Lean Construction in der Bauingenieurausbildung. *Bauingenieur* 19–25 (2019). VDI-Bautechnik, Jahressausgabe 2019/20, ISSN 0005-6650
11. Golovina, O., Teizer, J., Johansen, K.W., König, M.: Towards autonomous cloud-based close call data management for construction equipment safety. *Autom. Constr.* **132**, 103962 (2021). <https://doi.org/10.1016/j.autcon.2021.103962>
12. Chao E.L., Henshaw, J.L.: Job Hazard Analysis. OSHA Publication (2002). 3071 2002 (Revised). Occupational Safety and Health Administration, US Department of Labor
13. Li, B., Schultz, C., Melzner, J., Golovina, O., and Teizer, J.: Safe and lean location-based construction scheduling. In: 37th International Symposium on Automation and Robotics in Construction (2020). <https://doi.org/10.22260/ISARC2020/0195>
14. Sacks, R., Brilakis, I., Pikas, E., Xie, H., Girolami, M.: *Construction with Digital Twin Information Systems*. Data-Centric Engineering, Cambridge University Press, Cambridge (2020)
15. Teizer, J., Johansen, K.W., Schultz, C.: The concept of digital twin for construction safety. In: Construction Research Congress, Arlington, Virginia, USA, pp. 1156–1165. ASCE (2022). <https://doi.org/10.1061/9780784483961.121>
16. Laudan, L.: *Progress and Its Problems: Towards a Theory of Scientific Growth*, vol. 282. University of California Press, Berkeley (1978)
17. Beaney, M.: Analysis. In: Zalta, E.N. (ed.) *The Stanford Encyclopedia of Philosophy* (Summer 2018 Edition) (2018). <https://plato.stanford.edu/archives/sum2018/entries/analysis/>
18. BG Bau. Absturzsicherungen auf Baustellen (2019). [https://www.bgbau.de/fileadmin/Medien-Objekte/Medien/Bausteine/b\\_100/b\\_100.pdf](https://www.bgbau.de/fileadmin/Medien-Objekte/Medien/Bausteine/b_100/b_100.pdf). Accessed 20 Feb 2023
19. Occupational Safety and Health Administration. Commonly used statistics (2020). [www.osha.gov/data/commonstats](http://www.osha.gov/data/commonstats). Accessed 20 June 2023
20. Johansen, K.W., Schultz, C., Teizer, J.: A graph-based approach to minimize redundant spatial computations for automated construction safety prevention through design and planning. In: International Conference on Computing in Civil Engineering (i3CE), Corvallis, Oregon, USA (2023)
21. Hong, K., Teizer, J.: A data-driven method for hazard zone identification in construction sites with wearable sensors. In: CIBW099W123, Porto, Portugal, pp. 41–48 (2023). <https://doi.org/10.24840/978-972-752-309-2>. ISBN 978-972-752-309-2
22. Speiser, K., Teizer, J.: An efficient approach for generating training environments in virtual reality using a digital twin for construction safety. In: CIBW099W123, Porto, Portugal, pp. 481–490 (2023). <https://doi.org/10.24840/978-972-752-309-2>. ISBN 978-972-752-309-2

# Author Index

## B

Bauknecht, Ralph 69  
Beck, Benjamin 157  
Bertalan, Bálint 33  
Bohács, Gábor 33  
Borrmann, André 48  
Brell-Cokcan, Sigrid 23

## C

Cai, Zhen 3  
Cha, Suhyun 166  
Chen, Jan-Kristof 89

## D

Deininger, Isabella 69  
Díaz, Joaquín 137

## E

Emig, Julius 176

## F

Falk, Christoph 69  
Fischer, Anne 3  
Fottner, Johannes 3  
Fottner, Johannes 79, 89

## G

Gagliardo, Andrea 194  
Garbin, Simone 194  
Giusti, Andrea 194  
Golovina, Olga 201

## H

Haben, Fabian 115  
Heißenberger, Julia 123  
Heuer, Christoph 23  
Hochrein, Alexander 3

Hong, Kepeng 201  
Huber, Adrian Josef 79  
Hujo, Dominik 166

## I

Ibrahim, Ahmed 59

## J

Johansen, Karsten W. 201  
Jung, Victoria 23  
Juraboev, Abduaziz 137

## K

Kerausch, Cornelia 166  
Kern, Rüdiger 137  
Khan, Rehan 59  
Koch, Bernd 69  
König, Markus 40, 184  
Kortmann, Jan 149  
Krüger, Marius 89, 115, 166

## L

Land, Kathrin 89  
Langhans, Mathias 69  
Lipsmeier, Klaus 3  
Liu, Yan 40

## M

Mahmoudi, Elham 184  
Matt, Dominik T. 176, 194  
Miklautsch, Philipp 123  
Mischke, Janik 149

## N

Neumann, Eva-Maria 115  
Niethammer, Manuela 107  
Nübel, Konrad 69

**O**

Otto, Jens 149

**P**

Pfitzner, Fabian 48

Pohl, Daniel 166

Prinz, Theresa 166

**R**

Richter, Christian 149

**S**

Salloum, Yara 184

Schlenger, Jonas 48

Schneider, Michael 3

Schultz, Carl L. 201

Schwager, Inga-Leena 15

Schweder, Marcel 107

Siegele, Dietmar 176

Slongo, Cinzia 176

Speiser, Kilian 201

Starke, Martin 107

Suess, Sebastian 137

**T**

Teizer, Jochen 201

Terzer, Michael 194

Theobald, Marc 97

Tomar, Rahul 59

Top, Felix 97

Trautmann, Andreas 69

**V**

Vogel-Heuser, Birgit 89, 115, 166

**W**

Walch, Johanna 166

Waurich, Volker 107, 157

Weber, Jürgen 157

Wieringa, Timotheus 115

Will, Frank 107, 149, 157

Woschank, Manuel 123

**Y**

Ye, Xuling 40

**Z**

Zeng, Ningshuang 40